

CE

SPEED FACER

ODF70 SPEED FACER
NOTICE D'UTILISATION
CONSIGNES INITIALES



H&S TOOL
A CLIMAX COMPANY

P/N 87524
Mars 2017
Révision 1

CLIMAX
Family of Brands

BORTECH

CALDER
TESTERS

H&S TOOL

©2017 Climax Portable Machining and Welding Systems ou ses filiales.
Tous droits réservés

Sauf dispositions contraires expressément énoncées dans le présent document, aucune partie de la présente notice ne peut être reproduite, copiée, transmise, diffusée, téléchargée ou sauvegardée sur quelque support que ce soit, sans autorisation écrite préalable de la part de Climax. Dans la présente notice, Climax accorde l'autorisation de télécharger une seule copie de la présente notice et de toute révision sur un moyen de sauvegarde électronique pour visualisation et d'imprimer une copie de la présente notice ou de toute version revue de celle-ci, pourvu que toute copie, soit électronique, soit imprimée, de la présente notice ou révision contienne le texte intégral de la présente remarque au sujet des droits d'auteur et à condition que toute diffusion commerciale non autorisée de la présente notice ou de toute révision de celle-ci soit interdite.

Chez Climax Portable Machining and Welding Systems, nous valorisons votre opinion.

Pour tout commentaire ou toute question concernant la présente notice ou d'autres documentations Climax, veuillez nous envoyer un courrier électronique à documentation@cpmt.com.

Pour tout commentaire ou toute question concernant des produits ou des services Climax, veuillez appeler Climax ou envoyer un courrier électronique à info@cpmt.com. Pour un service rapide et précis, veuillez fournir à l'agent agréé de l'usine de votre région les éléments suivants :

- votre nom
- l'adresse d'expédition
- votre numéro de téléphone
- le modèle de la machine
- le numéro de série (le cas échéant)
- la date d'acquisition

Siège social mondial de Climax

Climax Portable Machining and Welding Systems
2712 South Second Street Newberg, Oregon 97132 USA
Téléphone (international) : +1 (503) 538-2815
Appel gratuit (pour l'Amérique du Nord) : 1-800-333-8311
Fax : +1 (503) 538-7600
Courrier électronique : info@cpmt.com

Siège social de Climax pour le R.U.

Climax Portable Machine Tools Ltd
Unit 10 Heather Close
Lyme Green Business Park
Macclesfield, Cheshire SK11 0LR, UK
Téléphone : +44 (0) 161 406 1720
Courrier électronique : info@cpmt.com

Siège social de Climax pour l'Europe

Climax GmbH
Am Langen Graben 8
52353 Düren, Germany
Téléphone : +49 (0) 2421-9177-12
Courrier électronique : info@cpmt.de

SITES MONDIAUX CLIMAX



DOCUMENTATION CE**Name of manufacturer or supplier**

H&S Tool

Full postal address including country of origin

715 Weber Drive
Wadsworth, OH 44281
USA

Description of product

ODF70 Speedfacer Flange Facer

Name, type or model, batch or serial number

Model ODF70

Serial Number Range OD70071601 to
OD70122001

Pneumatic Powered

Standards used, including number, title, issue date and other relative documents

EN 953, EN 3744, EN 4413, EN 4414, EN 11201, EN 12100, EN 13128, EN 13732, EN 13849, EN 13857

Name of Responsible Person within the EU Tom Cunningham**Full postal address if different from manufacturers**

Climax GmbH
Am Langen Graben 8
52353 Duren, Germany

Declaration

I declare that as the Manufacturer, the above information in relation to the supply / manufacture of this product, is in conformity with the stated standards and other related documents following the provisions of the above Directives and their amendments.

Signature of Manufacturer: Position Held: *Director of Engineering; R&D*Date: *7/20/2011*

GARANTIE LIMITÉE

Climax Portable Machine Tools, Inc. (ci-après dénommé « Climax ») garantit que toutes les machines neuves ne présentent aucun défaut ni du point de vue des pièces ni de la main d'œuvre. Cette garantie est accordée à l'acheteur initial pour une période d'un an à compter de la date de livraison. Si l'acheteur initial décèle un défaut dans les matériaux ou la fabrication, dans les limites de la période de garantie, il devra contacter l'agent agréé de l'usine et retourner la machine dans son intégralité à l'usine, frais d'expédition prépayés. Climax procédera, à sa seule discrétion, soit à la réparation, soit au remplacement de la machine défectueuse, à titre gratuit et restituera la machine au client, frais d'expédition prépayés.

Climax garantit que toutes les pièces sont exemptes de tout défaut de matériaux et de fabrication et que tous les travaux ont été réalisés de façon appropriée. Cette garantie est accordée au client au titre de l'achat de pièces ou de main d'œuvre pour une période de 90 jours à compter de la date de livraison de la pièce ou de la machine réparée ou de 180 jours pour les machines et les composants d'occasion. Au cas où le client qui aurait acheté des pièces ou de la main d'œuvre trouverait un quelconque défaut de matériaux ou de fabrication dans les limites de la période de garantie, l'acheteur devra s'adresser à l'agent agréé de l'usine et retourner la pièce ou la machine à réparer à l'usine, frais d'expédition prépayés. Climax procédera, à sa seule discrétion, soit à la réparation soit au remplacement de la pièce défectueuse et/ou à la correction de tout défaut dans les travaux réalisés, les deux sans aucun frais et restituera la pièce ou la machine réparée au client, frais d'expédition prépayés.

Ces garanties ne s'appliquent pas aux cas suivants :

- Dommage survenu après la date d'expédition et non provoqué par des défauts de matériaux ou de fabrication ;
- Dommage provoqué par un entretien inapproprié ou inadéquat ;
- Dommage provoqué par une modification ou une réparation non autorisée de la machine ;
- Dommage provoqué par une mauvaise utilisation de la machine ;
- Dommage provoqué par une utilisation de la machine au-delà de sa capacité nominale.

Toutes les autres garanties, explicites ou implicites, y compris, mais sans s'y limiter, les garanties de valeur marchande et de compatibilité à une utilisation spécifique sont déclinées et exclues.

Conditions générales de vente

Assurez-vous de prendre connaissance des conditions générales de vente qui figurent au verso de votre facture. Ces dispositions commandent et limitent vos droits vis à vis des biens achetés auprès de Climax.

À propos de la présente notice

Climax fournit le contenu de la présente notice de bonne foi au titre de consignes à l'intention de l'utilisateur. Climax ne peut pas garantir que les informations figurant dans la présente notice soient correctes pour des applications autres que celle décrite dans ladite notice. Les caractéristiques techniques du présent produit sont susceptibles de changer sans préavis.

TABLE DES MATIÈRES

| CHAPITRE/SECTION | PAGE |
|---|-------------|
| 1 INTRODUCTION | 1 |
| 1.1 COMMENT UTILISER LA PRÉSENTE NOTICE | 1 |
| 1.2 ALERTES DE SÉCURITÉ | 1 |
| 1.3 CONSIGNES GÉNÉRALES DE SÉCURITÉ | 2 |
| 1.4 PRÉCAUTIONS DE SÉCURITÉ SPÉCIFIQUES À LA MACHINE | 3 |
| 1.5 ÉVALUATION DES RISQUES ET ATTÉNUATION DES DANGERS | 4 |
| 1.6 LISTE DE VÉRIFICATION DE L'ÉVALUATION DES RISQUES | 5 |
| 1.7 ÉTIQUETTES | 6 |
| 1.7.1 Identification des étiquettes | 6 |
| 1.7.2 Emplacement des étiquettes | 7 |
| 2 APERÇU GÉNÉRAL | 9 |
| 2.1 DISPOSITIFS ET COMPOSANTS | 9 |
| 2.2 COMMANDES | 10 |
| 2.3 DIMENSIONS | 10 |
| 2.4 CARACTÉRISTIQUES TECHNIQUES | 12 |
| 2.5 ARTICLES NÉCESSAIRES MAIS NON FOURNIS | 12 |
| 3 MISE EN PLACE | 13 |
| 3.1 RÉCEPTION ET INSPECTION | 13 |
| 3.2 LEVAGE ET ARRIMAGE | 13 |
| 3.3 RISQUES À L'INSTALLATION | 15 |
| 3.3.1 Montage horizontal | 16 |
| 3.3.2 Montage vertical | 16 |
| 3.3.3 Montage au-dessus de la tête | 17 |
| 3.4 ASSEMBLAGE DE LA MACHINE | 17 |
| 3.4.1 Centrage et mise à niveau | 18 |
| 3.4.2 Installation de l'embout de coupe ou du porte-plaquette | 19 |
| 3.4.3 Rotation de la tête d'outil | 20 |
| 3.4.4 Réglage de l'avance | 20 |
| 3.4.5 Installation du moteur d'entraînement | 21 |
| 3.4.6 Raccordement de l'Air Caddy | 21 |
| 4 FONCTIONNEMENT | 23 |
| 4.1 CONTRÔLES PRÉALABLES AU FONCTIONNEMENT | 23 |
| 4.2 MODES DE FONCTIONNEMENT | 23 |
| 4.2.1 Configuration du surfaçage de bride | 23 |
| 4.2.2 Configuration d'un lamage | 24 |
| 4.2.3 Installation de la fixation en face arrière | 24 |

TABLE DES MATIÈRES (SUITE)

| CHAPITRE/SECTION | PAGE |
|---|-------------|
| 4.3 FONCTIONNEMENT | 25 |
| 4.3.1 Démarrage de la machine | 25 |
| 4.3.2 Arrêt de la machine | 26 |
| 4.3.3 Adaptation de la configuration de la machine | 26 |
| 5 ENTRETIEN | 27 |
| 5.1 LISTE DE VÉRIFICATION D'ENTRETIEN | 27 |
| 5.2 LUBRIFIANTS APPROUVÉS | 27 |
| 5.3 TÂCHES D'ENTRETIEN | 28 |
| 5.3.1 Vérification du réservoir à huile et du piège du filtre à particules de l'Air Caddy | 28 |
| 5.3.2 Vérification du circuit de coupure de l'Air Caddy | 29 |
| 5.3.3 Test du bouton d'arrêt d'urgence | 29 |
| 5.3.4 Passages queue d'aronde | 29 |
| 5.3.5 Installation et retrait du protecteur | 29 |
| 5.3.6 Réglage des rouleaux | 30 |
| 5.4 DÉPANNAGE | 31 |
| 5.4.1 La machine ne tourne pas | 31 |
| 5.4.2 La machine n'avance pas | 31 |
| 5.4.3 Les performances de la machine sont médiocres | 31 |
| 5.4.4 La coupe de la machine n'est pas plate | 31 |
| 6 ENTREPOSAGE ET EXPÉDITION | 33 |
| 6.1 ENTREPOSAGE | 33 |
| 6.1.1 Entreposage de courte durée | 33 |
| 6.1.2 Entreposage de longue durée | 33 |
| 6.2 EXPÉDITION | 34 |
| 6.3 MISE HORS SERVICE | 34 |
| ANNEXE A DESSINS D'ASSEMBLAGE | 35 |
| ANNEXE B N° FDS | 55 |

LISTE DE FIGURES

| FIGURE | PAGE |
|---|-------------|
| 1-1 Emplacement de l'étiquette ODF70 | 8 |
| 1-2 Emplacement de l'étiquette 60220 (sous la machine) | 8 |
| 2-1 Pieds d'extension mis en place | 9 |
| 2-2 Commandes Air caddy | 10 |
| 2-3 ODF70 Speed Facer dimensions (P/N 87000) | 11 |
| 3-1 Points de levage (machine ODF40) | 14 |
| 3-2 Danger dans le sens vertical | 15 |
| 3-3 Variantes de montage | 16 |
| 3-4 Trous de montage alternatifs | 17 |
| 3-5 Emplacement du boulon et de l'alésage | 18 |
| 3-6 Composants du pied de nivellement | 18 |
| 3-7 Indicateur à aiguille installé pour le nivellement | 19 |
| 3-8 Emplacement de la vis de serrage oscillante | 19 |
| 3-9 Emplacement du doigt d'embrayage de l'avance | 20 |
| 3-10 Réglages de l'avance | 21 |
| 3-11 Moteur d'entraînement pneumatique installé | 21 |
| 4-1 Vis de blocage | 24 |
| 4-2 Composants pour fixation arrière | 24 |
| 4-3 Commandes Air caddy | 25 |
| 4-4 Vis de réglage de l'avance et bouton de direction de l'avance | 25 |
| 5-1 Clé polygonale sur la vis | 29 |
| 5-2 Poinçons utilisés pour l'installation du protecteur | 30 |
| 5-3 Clé de réglage du rouleau (P/N 86988) | 30 |
| 6-1 Caisse de la ODF70 | 34 |
| A-1 Ensemble ODF70 Speed Facer (P/N 87000) | 36 |
| A-2 Étiquettes de l'ensemble ODF70 Speed Facer (P/N 87000) | 37 |
| A-3 Listes de pièces de l'ensemble ODF70 Speed Facer (P/N 87000) | 38 |
| A-4 Ensemble chariot coulissant porte-outil (P/N 79790) | 39 |
| A-5 Liste des pièces ensemble chariot coulissant porte-outil | 40 |
| A-6 Ensemble bloc de conditionnement pneumatique (P/N 83430) | 41 |
| A-7 Ensemble bloc de conditionnement pneumatique (P/N 83430) | 42 |
| A-8 Bloc pied de poussée de nivellement (P/N 86880) | 43 |
| A-9 Ensemble axe radial (P/N 86890) | 44 |
| A-10 Liste des pièces ensemble axe radial (P/N 86890) | 45 |
| A-11 Ensemble module d'avance à câble (P/N 86900) | 46 |
| A-12 Actionneur de l'avance dans l'ensemble module d'avance à câble (P/N 86900) | 47 |
| A-13 Ensemble doigt d'embrayage (P/N 86910) | 48 |
| A-14 Bloc de pied de poussée sans nivellement (P/N 86970) | 49 |
| A-15 Bloc moteur d'entraînement (P/N 86989) | 50 |
| A-16 Ensemble pied d'extension (P/N 87164) | 51 |
| A-17 Ensemble fixation en face arrière (P/N 87310) | 52 |

Cette page est laissée vierge intentionnellement

LISTE DE TABLEAUX

| TABLEAU | PAGE |
|--|-------------|
| 1-1 Niveaux sonores | 3 |
| 1-2 Liste de vérification de l'évaluation des risques avant la mise en place | 5 |
| 1-3 Liste de vérification de l'évaluation des risques après la mise en place | 5 |
| 1-4 ODF70 Speed Facer Étiquettes | 6 |
| 2-1 Poids du sous-composant | 12 |
| 3-1 Pieds de montage ODF70 | 18 |
| 5-1 Intervalles d'entretien et tâches à réaliser | 27 |
| 5-2 Lubrifiants approuvés | 28 |
| A-1 Kit d'outils P/N 78530 | 53 |

Cette page est laissée vierge intentionnellement

1 INTRODUCTION

DANS CE CHAPITRE :

| | |
|---|---|
| 1.1 COMMENT UTILISER LA PRÉSENTE NOTICE | 1 |
| 1.2 ALERTES DE SÉCURITÉ | 1 |
| 1.3 CONSIGNES GÉNÉRALES DE SÉCURITÉ | 2 |
| 1.4 PRÉCAUTIONS DE SÉCURITÉ SPÉCIFIQUES À LA MACHINE | 3 |
| 1.5 ÉVALUATION DES RISQUES ET ATTÉNUATION DES DANGERS | 4 |
| 1.6 LISTE DE VÉRIFICATION DE L'ÉVALUATION DES RISQUES | 5 |
| 1.7 ÉTIQUETTES | 6 |
| 1.7.1 IDENTIFICATION DES ÉTIQUETTES | 6 |
| 1.7.2 EMBLACEMENT DES ÉTIQUETTES | 7 |

1.1 COMMENT UTILISER LA PRÉSENTE NOTICE

La présente notice fournit les informations nécessaires à la mise en place, le fonctionnement, la maintenance, le stockage, l'expédition et la mise hors service de la ODF70 Speed Facer.

Un sommaire figure en première page de chaque chapitre pour vous permettre de trouver les informations spécifiques plus facilement. Les annexes contiennent des informations supplémentaires sur le produit pour faciliter les tâches de mise en place, de fonctionnement et de maintenance.

Veillez lire l'intégralité de la présente notice pour vous familiariser avec la machine de surfacage de bride ODF70 Speed Facer avant de la mettre en place et de la faire fonctionner.

1.2 ALERTES DE SÉCURITÉ

Veillez porter une attention scrupuleuse sur les alertes de sécurité qui figurent dans la présente notice. Les alertes de sécurité attirent votre attention sur des situations dangereuses spécifiques que vous pouvez rencontrer lorsque la machine fonctionne.

Des exemples d'alertes de sécurité utilisées dans la présente notice sont définis ci-après¹:

DANGER

signale une situation dangereuse qui, si elle n'est pas évitée, **ENTRAÎNE** des blessures graves, voire la mort.

AVERTISSEMENT

signale une situation dangereuse qui, si elle n'est pas évitée, **POURRAIT ENTRAÎNER** des blessures graves, voire la mort.

ATTENTION

signale une situation dangereuse qui, si elle n'est pas évitée, pourrait entraîner des blessures légères ou modérées.

1. Pour de plus amples informations sur les alertes de sécurité, consultez *ANSI/NEMA Z535.6-2011, Product safety Information in Product Manuals, Instructions, and Other Collateral Materials (en anglais)*.

AVIS

signale une situation dangereuse qui, si elle n'est pas évitée, pourrait occasionner des dommages matériels, des défaillances de l'équipement ou des résultats d'usinage médiocres.

1.3 CONSIGNES GÉNÉRALES DE SÉCURITÉ

H&S se place à l'avant-garde en matière de promotion de la sécurité d'utilisation de machines-outils portatives. Assurer la sécurité nécessite un effort commun. En tant qu'utilisateur final, vous devez assumer votre part de responsabilité en connaissant votre environnement de travail et en appliquant, à la lettre, les procédures de fonctionnement et les précautions de sécurité contenues dans la présente notice ainsi que les consignes de sécurité de votre employeur.

Appliquez les précautions de sécurité suivantes lorsque vous faites fonctionner ou que vous travaillez aux abords de la machine.

Formation - Avant d'utiliser cette machine ou une autre machine-outil, vous devez recevoir une formation de la part d'un formateur qualifié. Veuillez contacter H&S pour des renseignements spécifiques relatifs à la formation.

Évaluation des risques - Travailler avec la machine ou à ses abords peut présenter des risques pour votre sécurité. Il vous incombe en tant qu'utilisateur final d'effectuer une évaluation des risques de chaque site de travail avant de mettre en place cette machine et de l'utiliser.

Usage prévu - Utilisez cette machine conformément aux instructions et consignes figurant dans la présente notice. N'utilisez pas cette machine pour un usage autre que celui décrit dans la présente notice.

Équipement de protection personnelle - Portez toujours un équipement de protection personnelle lors de l'utilisation de la présente ou de toute autre machine-outil. Des vêtements ignifuges dotés de manches longues recouvrant les bras et les jambes sont recommandés lors de l'utilisation de la machine. Des copeaux chauds provenant de la pièce usinée risquent de brûler ou d'inciser la peau nue.

Espace de travail - Maintenez l'espace de travail autour de la machine dégagé de tout objet

encombrant. Laissez cordons et tuyaux connectés à la machine. Tenez les autres cordons et tuyaux éloignés de l'espace de travail.

Levage - De nombreux composants de la machine H&S sont très lourds. Utilisez, chaque fois que possible, un équipement de levage et d'arrimage adéquats pour lever la machine ou ses composants. Utilisez toujours les points de levage désignés sur la machine. Suivez les instructions de levage figurant dans les procédures de mise en place de la présente notice.

Soupape déverrouillage/déconsignation - Verrouillez et consignez la machine avant de procéder à la maintenance.

Pièces mobiles - Les machines H&S comportent de nombreuses pièces et interfaces mobiles exposées, qui peuvent occasionner des chocs, pincements, coupures et autres blessures graves. À l'exception des commandes de fonctionnement stationnaires, évitez tout contact de vos mains ou de vos outils avec les pièces mobiles lors de l'utilisation de la machine. Retirez les gants et les bijoux, attachez vos cheveux et vos vêtements et protégez les objets dans vos poches pour prévenir toute introduction fortuite dans les pièces mobiles.

Contours saillants - Les outils de coupe et les pièces d'usinage ont des contours saillants susceptibles d'inciser la peau facilement. Portez des gants de protection et prêtez attention lorsque vous manipulez un outil de coupe ou une pièce d'usinage.

Surfaces brûlantes - Moteurs, pompes, HPU et outils de coupe peuvent générer en fonctionnement une chaleur suffisante pouvant causer de graves brûlures. Prêtez attention aux avertissements « Surface chaude » et évitez tout contact avec la peau dénudée avant que la machine ne soit refroidie.

1.4 PRÉCAUTIONS DE SÉCURITÉ SPÉCIFIQUES À LA MACHINE

Danger pour les yeux - Cette machine produit des copeaux métalliques lorsqu'elle fonctionne. Portez toujours une protection oculaire lorsque vous travaillez avec la machine.

Environnements à risque - N'utilisez pas la machine dans des environnements potentiellement dangereux comportant des risques liés à des substances explosives, à des substances chimiques toxiques ou à une irradiation.

Niveau sonore - Cette machine peut générer des niveaux sonores nuisibles. Une protection auditive est exigée lorsque vous utilisez cette machine ou que vous travaillez à proximité. Au cours d'essais, les niveaux sonores¹ énumérés dans Tableau 1-1 ont été constatés pour la machine.

TABLEAU 1-1. NIVEAUX SONORES

| | Moteur |
|---|-----------|
| Niveau de puissance acoustique | 102,3 dBA |
| Niveau de pression acoustique au poste de travail | 87,6 dBA |
| Niveau de pression acoustique dans le voisinage | 85 dBA |

Fixation de la machine - Ne faites pas fonctionner la machine à moins qu'elle ne soit fixée à la pièce d'usinage conformément à la présente notice. Lorsqu'elle est fixée au-dessus de la tête ou en verticale, ne retirez pas les équipements de levage avant que la machine ne soit entièrement fixée à la pièce d'usinage conformément à la présente notice.

Dans toutes les positions de fixation, vérifiez que la machine est attachée et fixée tel que, si elle devait glisser ou pivoter, elle ne cause aucun dommage et ne blesse personne.

1. Les essais de niveau sonore de la machine ont été réalisés conformément aux normes européennes harmonisées EN ISO 3744/2010 et EN 11201:2010.

1.5 ÉVALUATION DES RISQUES ET ATTÉNUATION DES DANGERS

Les machines-outils sont spécifiquement conçues pour réaliser des opérations d'enlèvement de matériaux de grande précision.

Les machines-outils à installation fixe comprennent des tours et des fraiseuses et sont généralement disponibles dans un magasin de vente de machines d'usinage. Elles sont installées à un emplacement fixe durant leur utilisation et sont considérées comme des machines à part entière et autonomes. Les machines-outils à installation fixe atteignent la rigidité nécessaire pour réaliser des opérations d'enlèvement de matériaux par le biais de la structure qui constitue une partie intégrante de la machine-outil.

Les machines-outils portatives sont conçues pour des applications d'usinage sur site. Elles sont généralement directement fixées à la pièce à usiner ou à une structure adjacente et obtiennent leur rigidité par le biais de la structure à laquelle elles sont attachées. L'objectif de la conception consiste à ce que la machine-outil portative et la structure qui lui est rattachée deviennent une unique machine complète durant le processus d'enlèvement de matériaux.

Pour obtenir les résultats escomptés et promouvoir la sécurité, l'utilisateur doit comprendre et appliquer les pratiques liées à la conception, aux réglages et à l'utilisation, spécifiques aux machines-outils portatives.

L'utilisateur doit réaliser une analyse et une évaluation des risques sur site globale relative à l'application prévue. En raison de la nature unique des applications d'usinage réalisées avec des machines portatives, il est habituel d'identifier un ou plusieurs dangers qu'il conviendra de parer.

Lors de l'évaluation des risques sur site, il est important de considérer la machine-outil portative et la pièce à usiner comme un ensemble.

1.6 LISTE DE VÉRIFICATION DE L'ÉVALUATION DES RISQUES

La liste de vérification ci-après n'est pas une liste exhaustive des éléments à prendre en compte lors de la mise en place et du fonctionnement de la machine-outil portable.

Toutefois, ces listes de vérification sont représentatives des types de risques que le monteur et l'opérateur doivent prendre en considération. Utilisez cette liste de vérification comme faisant partie intégrante de l'évaluation des risques.

TABLEAU 1-2. LISTE DE VÉRIFICATION DE L'ÉVALUATION DES RISQUES AVANT LA MISE EN PLACE

| Avant la mise en place | |
|--------------------------|---|
| <input type="checkbox"/> | J'ai pris note de tous les avertissements apposés sur la machine. |
| <input type="checkbox"/> | J'ai éliminé ou atténué tous les risques identifiés (tels que trébucher, se couper, s'écraser, se coincer, se cisailer ou se blesser par des objets tombants). |
| <input type="checkbox"/> | J'ai pris en considération le besoin de protection pour ma sécurité personnelle et j'ai installé toutes les protections nécessaires. |
| <input type="checkbox"/> | J'ai lu les instructions d'assemblage de la machine (Section 3.3) et j'ai dressé l'inventaire de tous les éléments nécessaires mais non fournis (Section 2.5). |
| <input type="checkbox"/> | J'ai créé un plan de levage, comprenant l'identification de l'équipement d'arrimage approprié pour chacun des levages nécessaires pendant la mise en place de la structure de support et de la machine. |
| <input type="checkbox"/> | J'ai localisé les trajectoires de chute impliquées dans les actions de levage et d'arrimage. J'ai pris toutes les précautions nécessaires pour tenir les ouvriers éloignés de la trajectoire de chute identifiée. |
| <input type="checkbox"/> | J'ai examiné le mode opérationnel de cette machine et identifié la meilleure position pour les commandes, le câblage et l'opérateur. |
| <input type="checkbox"/> | J'ai évalué et atténué tout autre risque potentiel spécifique à mon espace de travail. |

TABLEAU 1-3. LISTE DE VÉRIFICATION DE L'ÉVALUATION DES RISQUES APRÈS LA MISE EN PLACE

| Après la mise en place | |
|--------------------------|---|
| <input type="checkbox"/> | J'ai vérifié que la machine est installée en toute sécurité (conformément à Section 3) et que la trajectoire de chute potentielle est dégagée. Si la machine est en position surélevée, j'ai vérifié que la machine est protégée contre toute éventualité de chute. |
| <input type="checkbox"/> | J'ai identifié tous les points de pincement possibles provoqués par des pièces en rotation et j'en ai informé le personnel. |
| <input type="checkbox"/> | J'ai pris des mesures de confinement de tout éclat métallique ou copeau produit par la machine. |
| <input type="checkbox"/> | J'ai respecté les intervalles fixés pour l'entretien (Section 5.1) avec les lubrifiants recommandés (Section 5.2). |
| <input type="checkbox"/> | J'ai vérifié que tous les membres du personnel concernés disposent du matériel de protection personnelle ainsi que de tout matériel exigé par les réglementations ou le site. |
| <input type="checkbox"/> | J'ai vérifié que tous les membres du personnel concernés perçoivent les limites de la zone de risques et se tiennent à distance de la zone à risques. |
| <input type="checkbox"/> | J'ai évalué et atténué tout autre risque potentiel spécifique à mon espace de travail. |

1.7 ÉTIQUETTES

1.7.1 Identification des étiquettes

Les étiquettes d'avertissement ci-après devraient être apposées sur votre machine. Au cas où certaines seraient détériorées ou absentes, contactez H&S immédiatement pour les remplacer.

TABLEAU 1-4. ODF70 SPEED FACER ÉTIQUETTES







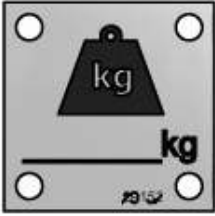

| | | | |
|---|--|---|---|
|  | <p>P/N 29152 Plaque de masse</p> |  | <p>P/N 46902 Étiquette d'avertissement : surface brûlante</p> |
|  | <p>P/N 59039 Étiquette d'avertissement : point de levage</p> |  | <p>P/N 59042 Étiquette d'avertissement : danger de happement des mains dans les pièces en mouvement</p> |
| <p>HOSE ARR </p> <p>BASE </p> | <p>PN 60219 Schéma de raccordement de tuyau pour rouge-rouge/bleu-bleu</p> | <p>HOSE ARR </p> <p>BASE </p> | <p>PN 60220 Schéma de raccordement de tuyau pour bleu-rouge/rouge-bleu</p> |
|  | <p>PN 79324 Étiquette d'avertissement : danger de prise des mains dans les engrenages en mouvement</p> |  | <p>PN 79385 Étiquette d'avertissement : soulever uniquement le sous-ensemble ; vérifier la notice d'utilisation</p> |

TABLEAU 1-4. ODF70 SPEED FACER ÉTIQUETTES

| | | | |
|--|---|--|--|
| | | <p>PN 84856</p> <p>Étiquette d'avertissement : attacher la machine avant utilisation</p> | |
| | | <p>PN 85262</p> <p>Étiquette H&S ODF70 Speed Facer</p> | |
| | <p>PN 87265</p> <p>Flèche noire sur fond jaune</p> | | <p>PN 87269</p> <p>Plaque signalétique H&S</p> |
| | <p>PN 87271</p> <p>Étiquette d'avertissement : porter une protection oculaire et auditive, lire la notice d'utilisation</p> | | <p>PN 87272</p> <p>Étiquette Made in the USA</p> |
| | | <p>PN 87430</p> <p>Étiquette H&S ODF70</p> | |

1.7.2 Emplacement des étiquettes

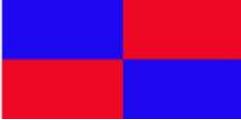
Les figures suivantes affichent l'emplacement des étiquettes sur chacun des composants de la machine ODF70 Speed Facer.

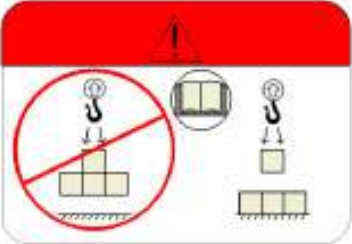
Pour une identification supplémentaire de l'emplacement veuillez consulter les vues exposées dans Annexe A.



FIGURE 1-1. EMPLACEMENT DE L'ÉTIQUETTE ODF70

Étiquette P/N : 29152, 46902, 59039, 59042, 60219, 79324, 79385, 84856, 85262, 87265, 87269, 87271, 87272, 87430

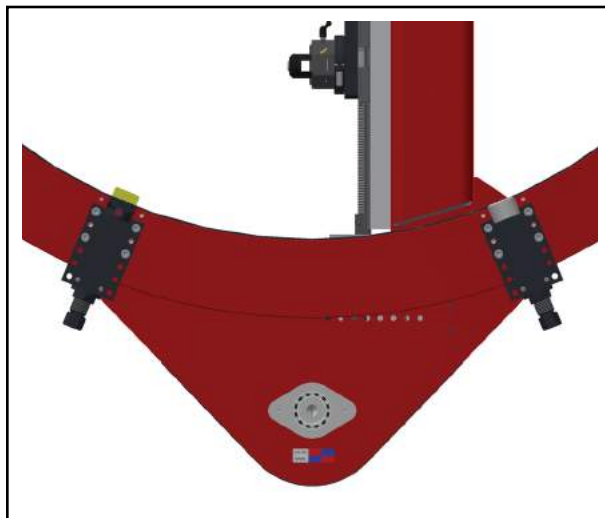

FIGURE 1-2. EMPLACEMENT DE L'ÉTIQUETTE 60220 (SOUS LA MACHINE)

Étiquette P/N : 60220

2 APERÇU GÉNÉRAL

DANS CE CHAPITRE :

| | |
|---|----|
| 2.1 DISPOSITIFS ET COMPOSANTS | 9 |
| 2.2 COMMANDES | 10 |
| 2.3 DIMENSIONS | 10 |
| 2.4 CARACTÉRISTIQUES TECHNIQUES | 12 |
| 2.5 ARTICLES NÉCESSAIRES MAIS NON FOURNIS | 12 |

2.1 DISPOSITIFS ET COMPOSANTS

La ODF70 Speed Facer est une machine pneumatique de surfacage de bride portative, entraînée par courroie, à fixation à point unique sur diamètre externe (DE), qui s'utilise sur des pièces d'usinage d'un diamètre externe (DE) de 59.1-70.5" (1,501-1,791 mm) ou 49.1-60.0" (1,247-1,524 mm) avec option de pieds de montage pour extension (Figure 2-1).



FIGURE 2-1. PIEDS D'EXTENSION MIS EN PLACE

Les principaux composants sont les suivants :

Moteur pneumatique – le moteur pneumatique a 1,35 CV, il est réversible et peut être monté en haut ou en bas de la machine selon les obstacles ou le mode de fonctionnement.

Pont d'outil à déplacement radial – l'axe radial intègre des passages linéaires et une vis à billes pour une course de 13,9" (353 mm). Il peut être repositionné sur le pont pour une coupe partant du DE maximum vers le point zéro central.

Ensemble porte-outil – la tête d'outil est également réglable sur un angle de 360 degrés pour l'avance axiale angulaire. Le support d'outil peut pivoter indépendamment afin de conserver la géométrie de l'outil. Les positions radiale et axiale peuvent être adaptées manuellement à l'aide d'une clé à cliquet 3/8".

Bloc d'avance automatique – le bloc d'avance automatique supprime la manipulation manuelle des poignées d'avance pendant le fonctionnement. ODF70 Speed Facer ODF40 Speed Facer comporte quatre doigts d'embrayage qui permettent d'activer le bloc d'avance réglable. L'avance se règle de 0,001 à 0,032" (0,03 à 0,8 mm) à chaque tour et peut s'utiliser sur l'un ou l'autre des axes.

Bloc de pied de blocage – les blocs de pied de blocage sont conçus uniquement pour le montage en diamètre externe. Les pieds de nivellement possèdent des mâchoires réglables et fonctionnent avec les doigts de mise au point pour mettre la machine de niveau. Consultez Section 3.3 on page 15 pour de plus amples informations sur les contraintes dimensionnelles relatives à la fixation.

Fixation en face arrière – la fixation en face arrière disponible en option permet l'accès à l'usinage en cas d'obstructions de passages. Elle peut aussi s'utiliser pour usiner l'arrière de brides de tuyau.

2.2 COMMANDES

Les commandes ODF70 Speed Facer sont placées sur le groupe de conditionnement pneumatique (Air Caddy) comme le montre la Figure 2-2.

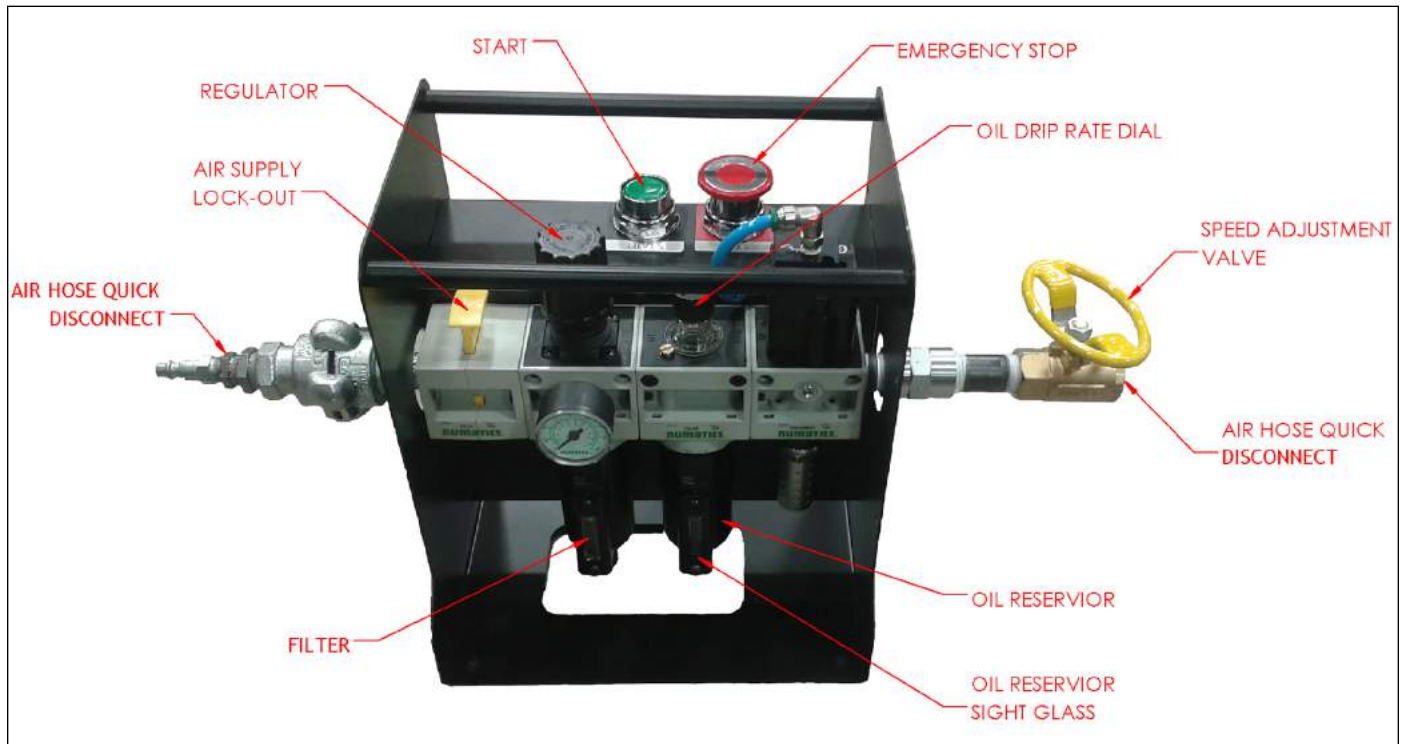

FIGURE 2-2. COMMANDES AIR CADDY

AVERTISSEMENT

Mettez toujours la machine en arrêt et verrouillez l'Air Caddy avant d'effectuer des réglages sur les commandes ou les composants de la machine. Si cette précaution de sécurité n'est pas respectée, de graves blessures peuvent en être les conséquences.

Arrêt d'urgence

Appuyez sur le bouton d'ARRÊT D'URGENCE (EMERGENCY STOP) sur l'Air Caddy pour arrêter immédiatement le fonctionnement de la machine.

Effectuez les actions suivantes avant de redémarrer la ODF70 Speed Facer :

1. Fermez la soupape de réglage de la vitesse.
2. Tirez le bouton d'ARRÊT D'URGENCE (EMERGENCY STOP) vers le haut.
3. Appuyez sur le bouton START (répétez step 1 si nécessaire).

2.3 DIMENSIONS

La Figure 2-3 indique la machine et les dimensions de fonctionnement.

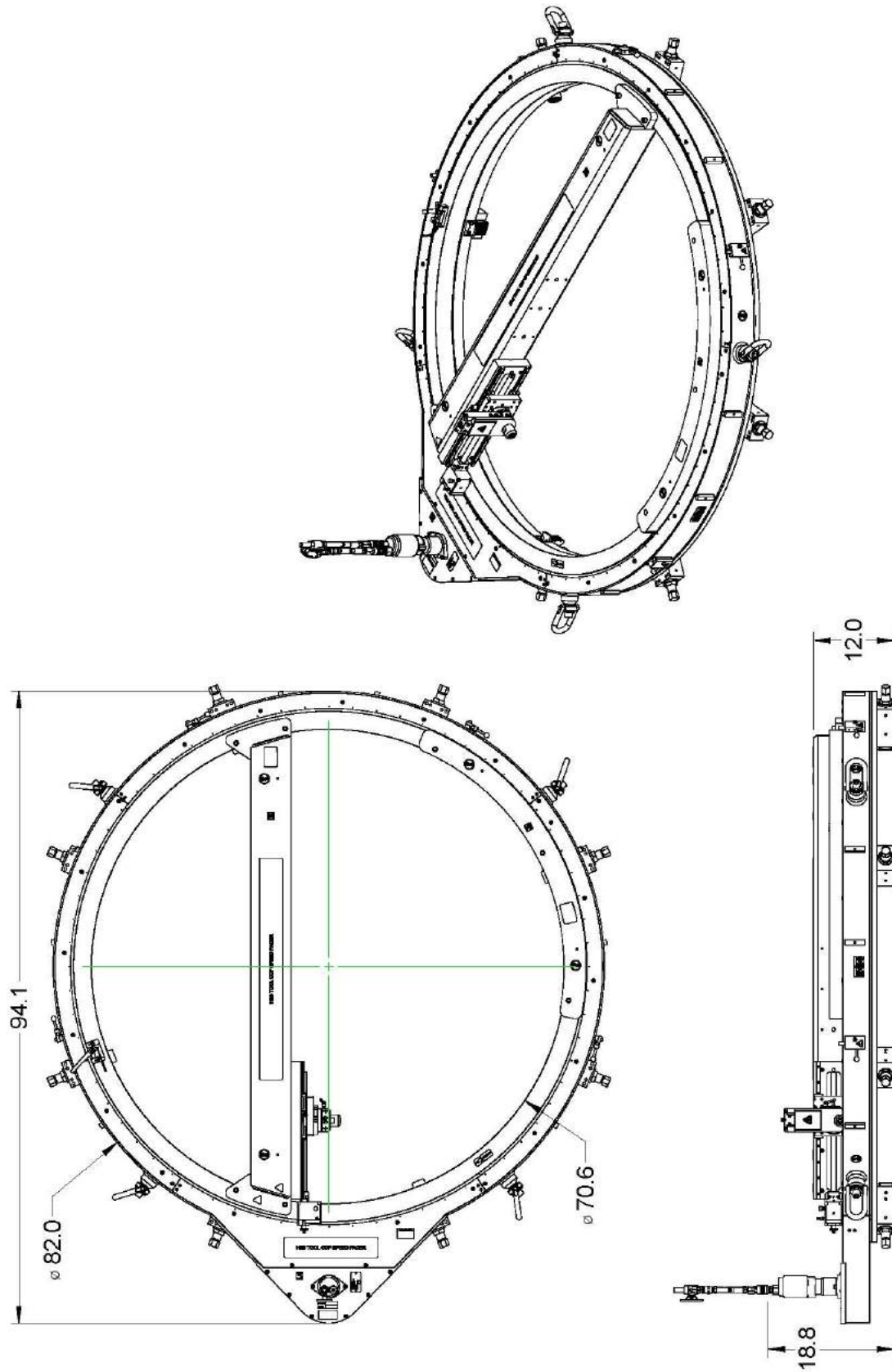

FIGURE 2-3. ODF70 SPEED FACER DIMENSIONS (P/N 87000)

2.4 CARACTÉRISTIQUES TECHNIQUES

TABLEAU 2-1. POIDS DU SOUS-COMPOSANT

| P/N: | Composant | Poids en lbs (kg) |
|-------|--|--------------------|
| 87164 | Ensemble kit d'extension pied et mandrin (eight total) | 22,5 (10,2) chacun |
| 87030 | Ensemble fixation en face arrière | 62 (28) |
| 87007 | ODF70 bridge weldment | 215 (98) |
| 87006 | ODF70 counterweight | 95 (43) |
| 87000 | ODF70 Speed Facer | 2,159 (979) |

2.5 ARTICLES NÉCESSAIRES MAIS NON FOURNIS

Les articles suivants sont nécessaire mais ne sont pas fournis avec votre kit produit H&S.

- Clé dynamométrique
- Indicateur à aiguille
- Bastaings en bois
- Mètre ruban

3 MISE EN PLACE

DANS CE CHAPITRE :

| | |
|--|----|
| 3.1 RÉCEPTION ET INSPECTION | 13 |
| 3.2 LEVAGE ET ARRIMAGE | 13 |
| 3.3 RISQUES À L'INSTALLATION | 15 |
| 3.3.1 MONTAGE HORIZONTAL | 16 |
| 3.3.2 MONTAGE VERTICAL | 16 |
| 3.3.3 MONTAGE AU-DESSUS DE LA TÊTE | 17 |
| 3.4 ASSEMBLAGE DE LA MACHINE | 17 |
| 3.4.1 CENTRAGE ET MISE À NIVEAU | 18 |
| 3.4.2 INSTALLATION DE L'EMBOU DE COUPE OU DU PORTE-PLAQUETTE | 19 |
| 3.4.3 ROTATION DE LA TÊTE D'OUTIL | 20 |
| 3.4.4 RÉGLAGE DE L'AVANCE | 20 |
| 3.4.5 INSTALLATION DU MOTEUR D'ENTRAÎNEMENT | 21 |
| 3.4.6 RACCORDEMENT DE L'AIR CADDY | 21 |

Cette section décrit les procédures de mise en place et d'assemblage de ODF70 Speed Facer.

3.1 RÉCEPTION ET INSPECTION

Votre produit H&S a été inspecté et essayé préalablement à l'expédition et emballé pour des conditions d'expédition normales. H&S ne garantit pas l'état de votre machine au-delà de la livraison.

Lorsque vous recevez votre produit H&S, effectuez les contrôles de réception suivants :

1. Inspectez les conteneurs d'expédition pour détecter d'éventuels dommages.
2. Contrôlez le contenu des conteneurs d'expédition par rapport à la facture incluse afin de vérifier que tous les composants ont été expédiés.
3. Inspectez tous les composants pour détecter d'éventuels dommages.

Contactez H&S immédiatement pour signaler des composants endommagés ou manquants.

AVIS

Conservez les conteneurs d'expédition ainsi que tous les matériaux d'emballage en vue d'un stockage et d'une expédition ultérieurs de la machine.

La machine est expédiée de chez H&S avec un revêtement épais en LPS 3. Le produit de nettoyage recommandé est le dégraissant LPS PreSolve Orange. Toutes les pièces de la machine doivent être nettoyées avant utilisation.

3.2 LEVAGE ET ARRIMAGE

Avant de déballer les conteneurs d'expédition, complétez la liste de vérification de l'évaluation des risques dans Tableau 1-2 on page 5.

Avant de procéder au levage, assurez-vous que toutes les pièces sont correctement fixées à la machine.

! DANGER

La ODF70 Speed Facer peut peser jusqu'à 2,159 lbs (979 kg), une fois complètement assemblée. Afin d'empêcher des blessures graves aux dépens de vous même et d'autres personnes, appliquez toujours les procédures d'utilisation exposées dans la présente notice, les règles de votre propre entreprise et les règlementations locales relatives au levage de poids lourds. Une méthode de levage erronée risque d'entraîner des blessures graves, voire la mort.

Procédez comme suit pour un levage correct :

1. Fixez quatre anneaux de levage orientables 3/4" à la machine, s'ils ne le sont pas déjà.

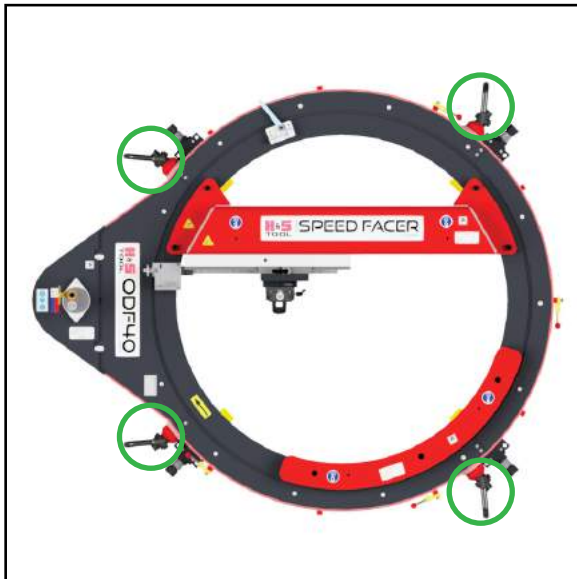

FIGURE 3-1. POINTS DE LEVAGE (MACHINE ODF40)

! ATTENTION

Une chute ou un basculement non contrôlé de la machine risque de blesser grièvement l'opérateur et les personnes présentes à proximité, voire de provoquer leur décès. Levez la machine assemblée uniquement par les anneaux de levage 3/4" que montre la Figure 3-1. Ne pas lever la ODF70 Speed Facer à l'aide des points de levage plus petits situés sur le pont ou le contrepoids.

2. Fixez l'équipement d'arrimage fourni par le client aux anneaux de levage sur le plateau.

! ATTENTION

Vérifiez la fixation correcte de l'équipement d'arrimage avant de lever la machine. Levez la machine lentement en s'assurant qu'aucun composant ne sera écrasé ou tordu si la machine est levée selon la verticale. Si l'arrimage entraîne une oscillation de la machine ou que celle-ci devient instable, abaissez-la et réglez l'arrimage.

3. Sortez la machine de sa caisse d'expédition.

3.3 RISQUES À L'INSTALLATION

La phase d'installation peut s'avérer dangereuse, car elle dépend du fait que l'opérateur et tout autre personnel suivent bien les consignes de sécurité recommandées. Tenez compte avec attention des avertissements qui suivent avant de procéder à l'assemblage.

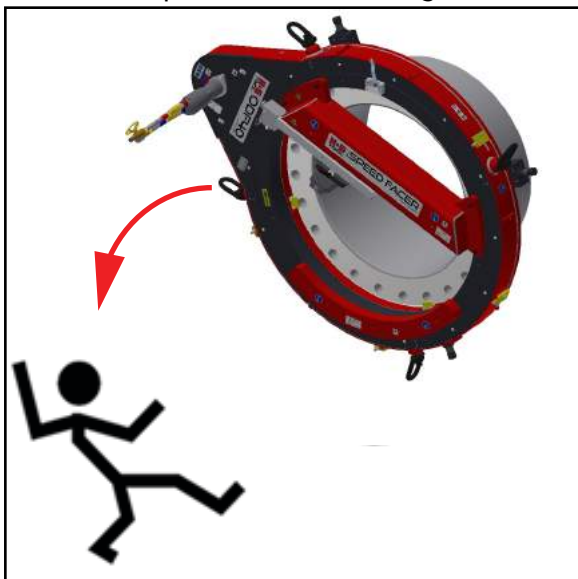

FIGURE 3-2. DANGER DANS LE SENS VERTICAL

⚠ AVERTISSEMENT

Si la machine n'est pas correctement fixée, elle risque de tomber et de causer des blessures mortelles au personnel. Portez une attention particulière aux installations à brides verticales et au-dessus de la tête.

Fixez correctement tous les composants avant de lever la machine. Utilisez un équipement d'arrimage supplémentaire pendant la mise en place.

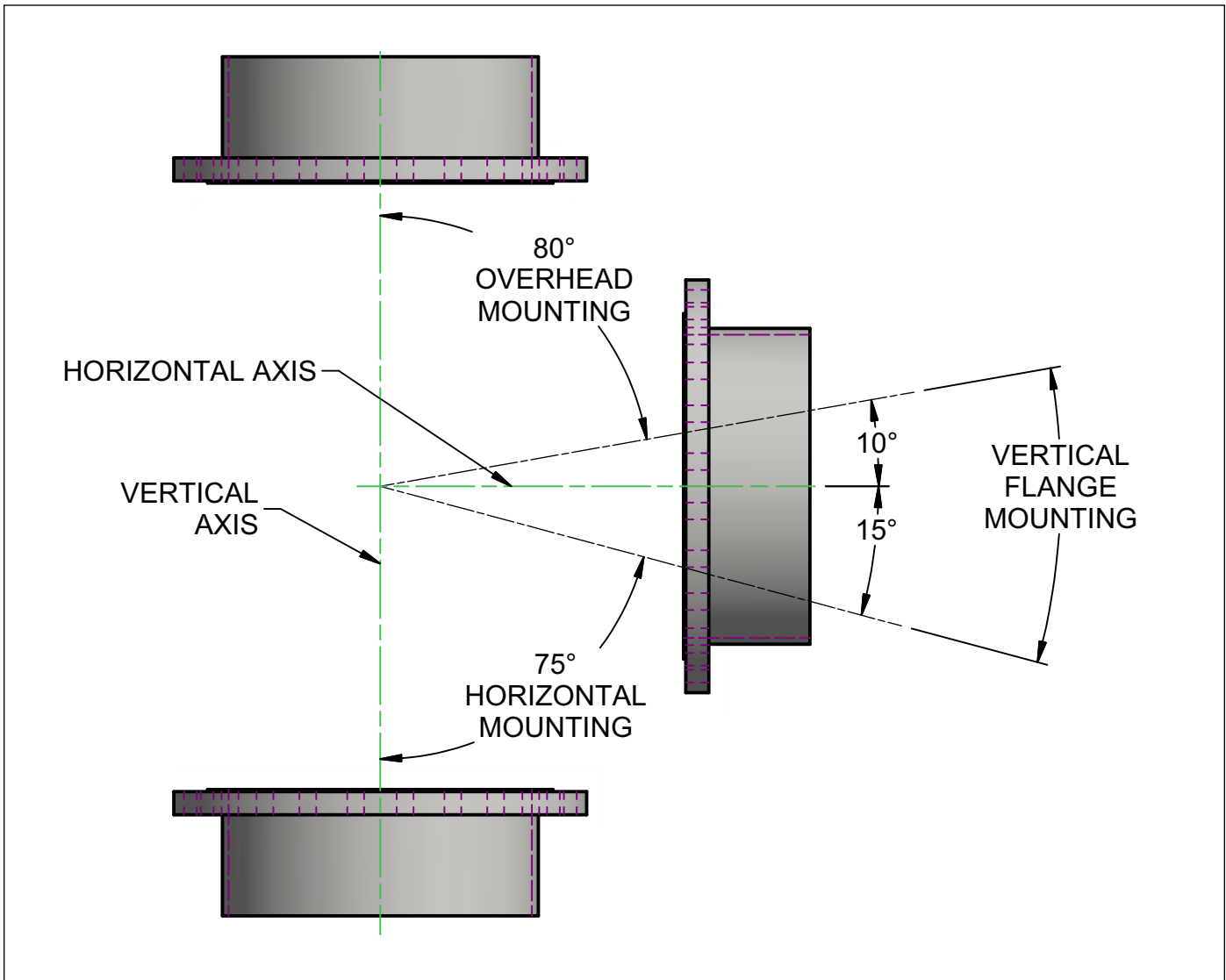

FIGURE 3-3. VARIANTES DE MONTAGE

3.3.1 Montage horizontal

Le risque encouru lors du montage horizontal est celui de la chute de la machine en se heurtant au pont d'outil soudé.

Les mesures d'atténuation comprennent l'une des variantes suivantes :

- Laissez les doigts de mise au point en place sur le dessus des pieds de nivellement.
- Si les doigts de mise au point doivent être retirés, bloquez la machine par le dessous ou fixez-la aux points d'ancrage au-dessus de la machine à l'aide d'au moins deux

anneaux de levage orientables opposés aux points d'ancrage et élingues (fournis par le client) adaptés au poids de la machine et élingue en angle. Voir Figure 3-3.

3.3.2 Montage vertical

Le risque encouru lors du montage vertical est celui de la chute de la machine hors de la bride.

Les mesures d'atténuation comprennent l'une des variantes suivantes :

- Installez les doigts de mise au point à l'arrière de la bride sur la « partie

inférieure » des pieds de nivellement (voir Figure 3-4).

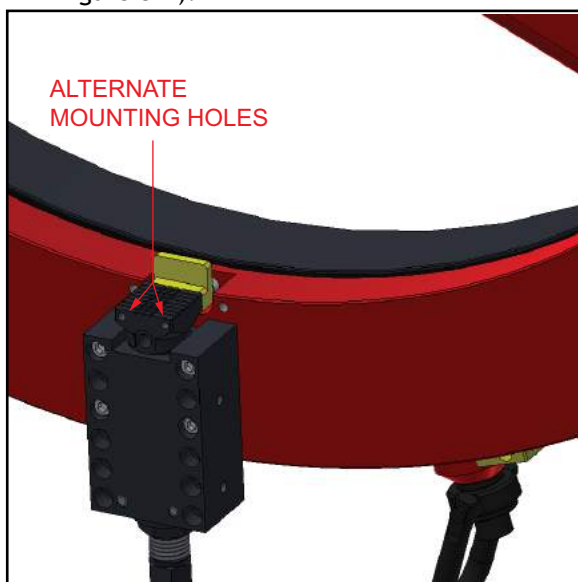

FIGURE 3-4. TROUS DE MONTAGE ALTERNATIFS

- Si l'épaisseur de la bride empêche l'utilisation des doigts de mise au point, bloquez la machine aux points d'ancrage au-dessus de la machine à l'aide d'au moins un anneau de levage orientables aux points d'ancrage et élingues (fournis par le client) adaptés au poids de la machine et élingue en angle. Voir Figure 3-3.

3.3.3 Montage au-dessus de la tête

Le risque encouru lors du montage au-dessus de la tête est celui de la chute de la machine hors de la bride.

Les mesures d'atténuation comprennent l'une des variantes suivantes :

- Installez les doigts de mise au point à l'arrière (dessus) de la bride sur la « partie inférieure » des pieds de nivellement (voir Figure 3-4).
- Si l'épaisseur de la bride empêche l'utilisation des doigts de mise au point, bloquez la machine aux points d'ancrage au-dessus de la machine à l'aide d'au moins deux anneaux de levage orientables opposés aux points d'ancrage et élingues (fournis par le client) adaptés au poids de la machine et élingue en angle. Voir Figure 3-3.

! ATTENTION

Dans chacun des cas, ces mesures de sécurité doivent être prises en compte pendant l'évaluation des risques et les dispositifs de retenue de la machine doivent être installés tel que toute oscillation ou autre mouvement de la machine soit réduit à un minimum absolu.

3.4 ASSEMBLAGE DE LA MACHINE

Procédez comme suit pour mettre la ODF70 Speed Facer en place :

1. Complétez la liste de vérification de l'évaluation des risques dans Tableau 1-2 on page 5.
2. Mesurez le diamètre extérieur de la bride à utiliser.

3. Placez la machine sur un support robuste afin d'installer les 8 pieds de montage selon le Tableau 3-1.

! AVERTISSEMENT

Si la machine n'est pas correctement montée et attachée, elle risque de se mettre à tourner et de chuter.

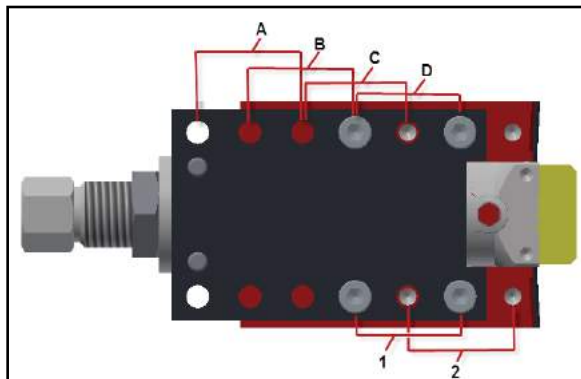

FIGURE 3-5. EMPLACEMENT DU BOULON ET DE L'ALÉSAGE

TABEAU 3-1. PIEDS DE MONTAGE ODF70

| DE minimum en pouces (mm) | DE maximum en pouces (mm) | Emplace- ment du boulon du pied | Emplace- ment de l'alésage du cadre |
|------------------------------|------------------------------|--|--|
| 67.02 (1,702) | 70.5 (1,791) | D | 1 |
| 65.02 (1,651) | 68.5 (1,740) | C | 1 |
| 63.02 (1,601) | 66.5 (1,689) | C | 2 |
| 61.02 (1,550) | 64.5 (1,638) | B | 2 |
| 59.02 (1,499) | 62.5 (1,588) | A | 2 |

4. Centrez la mâchoire de poussée de nivellement à l'aide du bras de poussée sur les blocs du pied de nivellement.
5. Réglez grossièrement les pieds de nivellement (un pied est montré sur la Figure 3-6) en tournant la vis de poussée du pied jusqu'à ce qu'ils soient à peu près plus larges de 1/8" (3 mm) que le DE de la bride.

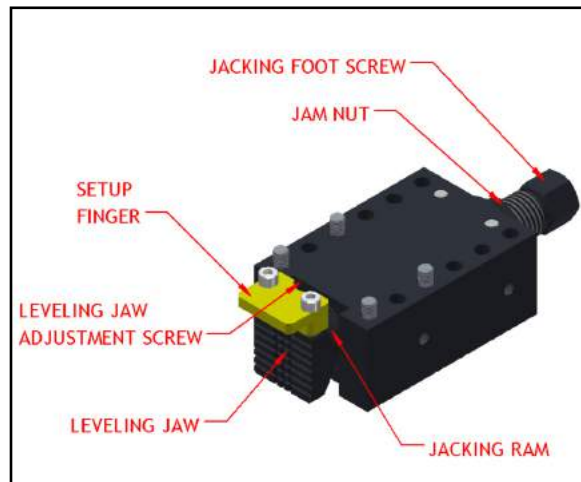

FIGURE 3-6. COMPOSANTS DU PIED DE NIVELLEMENT

AVIS

La course des mâchoires de poussée de nivellement et des mâchoires standard n'est que de 1,7" (43 mm).

6. Posez la machine sur la bride en plaçant les doigts de mise au point contre la surface de la bride de boulonnage.
7. Serrez les vis des pieds de nivellement de manière uniforme jusqu'à ce que les mâchoires adhèrent au DE de la bride selon un couple de serrage de 10 ft-lbs (14 Nm).

3.4.1 Centrage et mise à niveau

Procédez comme suit pour centrer et niveler la machine :

1. Pour un réglage grossier, vérifiez avec un mètre-ruban la distance entre le diamètre intérieur (DI) de la machine et le diamètre extérieur (DE) du tuyau au niveau des quatre pieds de nivellement.
2. Pour un réglage fin, utilisez un indicateur à aiguille dans le porte-outil qui vérifiera que les mesures sont les mêmes entre le DI de la machine et le DE du tuyau. Dans les deux cas, le réglage s'opère à l'aide des vis de poussée du pied.
 3. Alors que les doigts de mise au point réalisent le nivellement initial, procédez comme suit pour affiner la mise à niveau :
 - a) Installez un indicateur à aiguille dans le porte-outil centré sur la surface de bride surélevée.
 - b) Mettez l'indicateur à zéro sur le premier pied de nivellement et faire tourner la machine sur 180° pour aligner l'indicateur sur le pied opposé.
 - c) Relevez ou abaissez la mâchoire de la moitié de la différence entre les deux pieds à l'aide de la vis de réglage de la mâchoire de nivellement.
 - d) Répétez l'étape b et l'étape c pour les autres pieds de nivellement. Les applications habituelles exigent un alignement de la machine égal au maximum à 0,010" (0,25 mm).



FIGURE 3-7. INDICATEUR À AIGUILLE INSTALLÉ POUR LE NIVELLEMENT

4. Serrez les quatre pieds de poussée réglables selon un couple de 60 ft-lbs (81 Nm) en alternance.

AVERTISSEMENT

Vérifiez le serrage des pieds de poussée, il doit être de 60 ft-lbs (81 Nm) minimum. Une force de serrage insuffisante risque de faire tomber la machine de la pièce d'usinage, ce qui pourrait avoir pour conséquences de graves blessures corporelles, voire la mort, et des dommages matériels.

AVIS

Ne serrez pas excessivement les vis de poussée des pieds. Un serrage excessif pourrait déformer le cadre de rotation de la machine et être la cause d'un usinage aux résultats médiocres.

5. Serrez les quatre pieds de poussée sans nivellement selon un couple de 60 ft-lbs (81 Nm) en alternance.
6. Serrez les contre-écrous sur tous les pieds de poussée.

7. Retirez les doigts de mise au point des pieds de nivellement, si nécessaire, pour un usinage complet jusqu'au diamètre extérieur. Voir les sous-sections de la Section 3.3 on page 15 pour des informations sur la sécurisation de la machine.

3.4.2 Installation de l'embout de coupe ou du porte-plaquette

AVIS

La ODF70 Speed Facer est conçue pour traîner l'outil de coupe derrière le pont d'outil soudé. Le pont d'outil soudé pivote dans le sens horaire, vu du côté de la machine auquel le pont d'outil est fixé. Gardez à l'esprit ces caractéristiques lors de l'installation d'un nouvel outil sur la machine.

Procédez comme suit pour installer l'embout de coupe ou le porte-plaquette

1. Réglez la position correcte du porte-outil pour le démarrage de l'usinage.
2. Réglez le porte-outil selon l'angle d'oscillation souhaité (voir Figure 3-8).



FIGURE 3-8. EMPLACEMENT DE LA VIS DE SERRAGE OSCILLANTE

3. Pour installer l'outil approprié dans le support d'outil oscillant : desserrez la vis M20 du collier d'outil, insérez l'outil de coupe et serrez la vis M20.

ASTUCE :

Insérez toujours l'outil de coupe le plus loin possible dans le porte-outil pour garantir la stabilité.

4. Réglez l'outil à la profondeur de coupe souhaitée.

3.4.3 Rotation de la tête d'outil

Procédez comme suit pour faire tourner la tête de fraisage :

1. Desserrez les deux vis de serrage oscillantes pour dégager le collier de serrage circulaire à l'arrière de la tête d'outil.

⚠ ATTENTION

Ne desserrez pas la tête d'outil rapidement. Gardez une main sur la tête d'outil pour une meilleure stabilité. Un décrochage rapide de la tête d'outil peut la faire osciller de manière imprévue et entraîner des dommages corporels ou matériels.

2. Positionnez la tête d'outil.
3. Bloquez le collier de serrage en serrant les deux vis de serrage oscillantes.

Les repères gravés sur le collier de serrage permettent d'ajuster les angles dans une plage de plus ou moins 0,5 degré.

3.4.4 Réglage de l'avance

AVIS

Le bloc d'avance peut être placé sur le chariot coulissant radial ou axial, selon que l'opération d'usinage consiste à surfacer ou à aléser.

Procédez comme suit pour régler l'avance :

1. Installez les doigts d'embrayage tel qu'il est nécessaire (voir Figure 3-9).

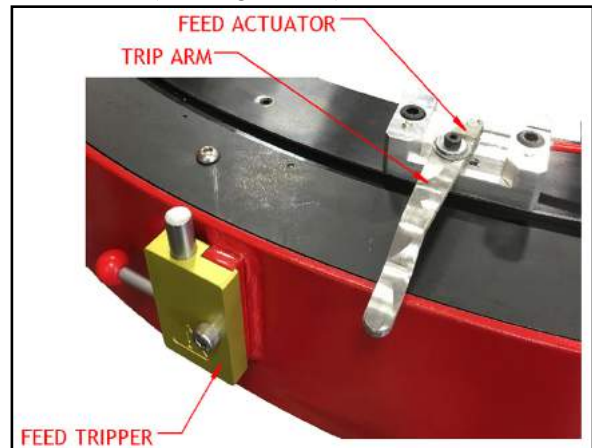

FIGURE 3-9. EMBRAYEMENT DU DOIGT D'AVANCE

ASTUCE :

Le nombre de doigts d'embrayage détermine la vitesse d'avance et la finition souhaitée. Quatre doigts d'embrayage sont inclus. Le module d'avance est réglable pour un tour entre 0,001 et 0,008" (0,003 et 0,2 mm) par déclenchement. Les finitions plus précises utilisent généralement un ou deux doigts d'embrayage, le réglage de l'avance étant plus petit par déclenchement. Les finitions grossières ou plus rapides utilisent les quatre doigts d'embrayage.

2. Réglez le sens d'avance en fonction des étapes qui suivent, comme le montre la Figure 3-10:
 - a) Poussez le bouton de direction de l'avance (pour qu'il rentre) pour embrayer l'avance vers le centre.
 - b) Tirez le bouton de direction de l'avance (pour qu'il ressorte) pour embrayer l'avance vers le diamètre extérieur.

ASTUCE :

Il peut être nécessaire de basculer légèrement le bouton lors du changement de direction de l'avance.

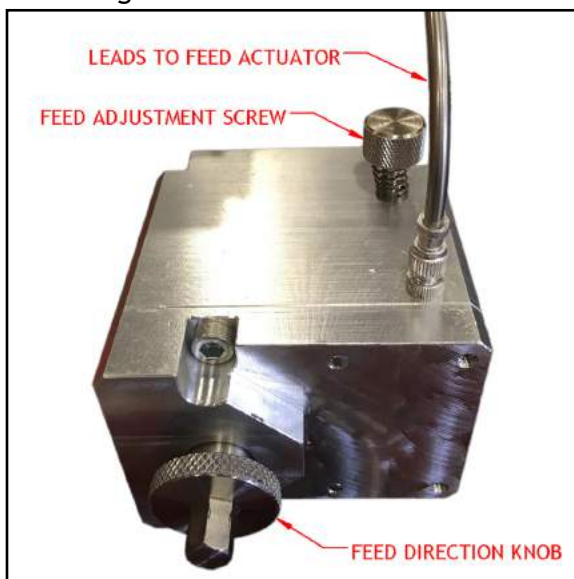

FIGURE 3-10. RÉGLAGES DE L'AVANCE

3. Réglez la distance d'avance par déclenchement.

AVIS

Lorsque la vis de réglage de l'avance est entièrement dévissée, la distance d'avance est au maximum, qui est d'environ de 0,008" (0,2 mm) par déclenchement. Lorsque la vis de réglage de l'avance est vissée, l'avance est au minimum. Le réglage de la vis à croisillon change l'angle du bras du contacteur sur l'actionneur de l'avance.

4. Posez et bloquez le câble d'avance pour l'empêcher de se tordre ou de s'accrocher à des obstacles.

3.4.5 Installation du moteur d'entraînement

Les étiquettes rouge-bleu (P/N 60219, 60220 sur le Tableau 1-4 on page 6) de chaque côté de la machine où le moteur pneumatique est installé montrent la disposition du tuyau pour rectifier la direction de fonctionnement du moteur.

Par exemple, si le moteur est installé sur le dessus, le tuyau rouge est raccordé au port rouge du moteur. Voir Figure 3-11.



FIGURE 3-11. MOTEUR D'ENTRAÎNEMENT PNEUMATIQUE INSTALLÉ

Procédez comme suit pour installer le moteur d'entraînement :

1. Contrôlez la présence de la clé d'entraînement dans l'emplacement sur l'arbre du moteur.
2. Fixez l'arbre du moteur d'entraînement dans le moyeu de l'entraînement en alignant la clé d'entraînement sur l'emplacement dans le moyeu.
3. Serrez les deux vis sur le collier de fixation pour bloquer.

3.4.6 Raccordement de l'Air Caddy

Raccordez l'Air Caddy à la machine par le débranchement de la vanne de réglage de la vitesse.

Cette page est laissée vierge intentionnellement

4 FONCTIONNEMENT

DANS CE CHAPITRE :

| | |
|--|----|
| 4.1 CONTRÔLES PRÉALABLES AU FONCTIONNEMENT | 23 |
| 4.2 MODES DE FONCTIONNEMENT | 23 |
| 4.2.1 CONFIGURATION DU SURFAÇAGE DE BRIDE | 23 |
| 4.2.2 CONFIGURATION D'UN LAMAGE | 24 |
| 4.2.3 INSTALLATION DE LA FIXATION EN FACE ARRIÈRE | 24 |
| 4.3 FONCTIONNEMENT | 25 |
| 4.3.1 DÉMARRAGE DE LA MACHINE | 25 |
| 4.3.2 ARRÊT DE LA MACHINE | 26 |
| 4.3.3 ADAPTATION DE LA CONFIGURATION DE LA MACHINE | 26 |

4.1 CONTRÔLES PRÉALABLES AU FONCTIONNEMENT

Effectuez les vérifications suivantes avant de faire fonctionner la machine :

1. Complétez la liste de vérification de l'évaluation des risques dans Tableau 1-3, page 5.
2. Vérifiez que l'espace de travail est dégagé de tout équipement et tout personnel non essentiel.
3. Vérifiez que la commande de la machine ou la zone d'observation ne se trouvent pas sur la trajectoire de projection de copeaux brûlants pendant le fonctionnement de la machine.
4. Vérifiez que la machine est montée en toute sécurité sur la pièce d'usinage, selon la Section 3.3, page 15.
5. Vérifiez que les tuyaux d'air comprimé sont enroulés et fixés afin d'éviter des trébuchements, des enchevêtrements, des détériorations causées par les copeaux brûlants ou tout autre dommage en cas de panne du tuyau ou du raccordement.
6. Vérifiez l'état de l'outil et son affûtage.
7. Sur l'Air Caddy, vérifiez que le débit d'huile est réglé sur six gouttes à la minute.
8. Vérifiez que tous les outils à main ont été retirés de la machine et de l'espace de travail.

4.2 MODES DE FONCTIONNEMENT

La ODF70 Speed Facer peut usiner les surfaces sur une bride plane ou conique, ainsi que des rainures ou des biseaux. Les sous-sections suivantes expliquent comment configurer la machine pour ces modes de fonctionnement. Voir Section 2.2, page 10 pour des informations sur les commandes.

4.2.1 Configuration du surfaçage de bride

Le surfaçage à plat est le mode de fonctionnement par défaut de la ODF70 Speed Facer.

AVERTISSEMENT

Ne configurez ni ne réglez le sens d'usinage avant que la machine ne soit mise à l'arrêt, que le tuyau d'air comprimé ait été débranché et que les verrouillages/déconsignations requis aient été effectués.

Effectuez les étapes suivantes pour configurer la ODF70 Speed Facer en vue de l'usinage d'une face de bride plane :

1. Assemblez la ODF70 Speed Facer sur la pièce d'usinage (voir Section 3.3, page 15).

2. Réalisez toutes les vérifications préalables au fonctionnement (voir Section 4.1).
3. Desserrez les deux vis de blocage radiale et axiale.

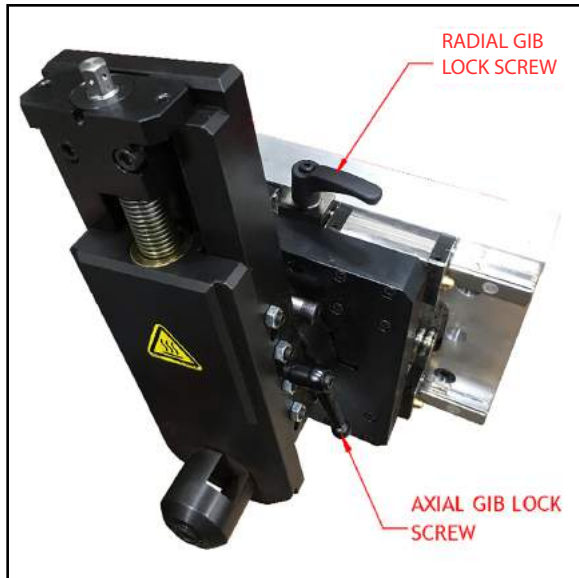

FIGURE 4-1. VIS DE BLOCAGE

4. Utilisez une clé à cliquet 3/8" sur les vis d'avance radiale et axiale afin de positionner l'outil de coupe au point de démarrage de la coupe.
5. Serrez à la main uniquement la vis de blocage axiale.
6. Réglez le bouton de direction de l'avance (comme le montre la Figure 4-4, page 25) dans le sens désiré.
7. Réglez la vitesse d'avance en se reportant à la Section 3.4.4, page 20 et à l'aide de la vis de réglage de l'avance sur le module d'avance.

4.2.2 Configuration d'un lamage

Effectuez les étapes suivantes pour configurer un lamage :

1. Assemblez la ODF70 Speed Facer sur la pièce d'usinage (voir Section 3.3, page 15).
2. Réalisez toutes les vérifications préalables au fonctionnement (voir Section 4.1).
3. Repositionnez le module d'avance de la vis d'avance radiale sur la vis d'avance axiale en la bloquant avec deux vis.
4. Desserrez les deux vis de blocage axiale et radiale.

5. Utilisez une clé à cliquet 3/8" sur les vis d'avance radiale et axiale afin de positionner l'outil de coupe au point de démarrage de la coupe.
6. Serrez à la main uniquement la vis de blocage radiale.
7. Réglez le bouton de direction de l'avance dans la position désirée. Dans cette configuration, appuyer pour enfoncer le bouton de direction de l'avance fait s'éloigner la coupe de l'opérateur.
8. Réglez la vitesse d'avance en se reportant à la Section 3.4.4, page 20 et à l'aide de la vis de réglage de l'avance sur le module d'avance.

4.2.3 Installation de la fixation en face arrière

La ODF70 Speed Facer peut aussi être configurée avec la fixation en face arrière disponible en option. Cette configuration permet un surfacage de bride lorsqu'il existe des obstacles qui passent dans le tuyau et également un usinage de la face arrière de la bride de boulonnage.

Procédez comme suit pour configurer la machine pour la fixation en face arrière :

1. Retirez à la fois le pont d'outil soudé et le contrepois de la machine. Observer les poids affichés et effectuez les procédures correctes de levage et de déplacement telles que décrites à la Section 3.2, page 13.

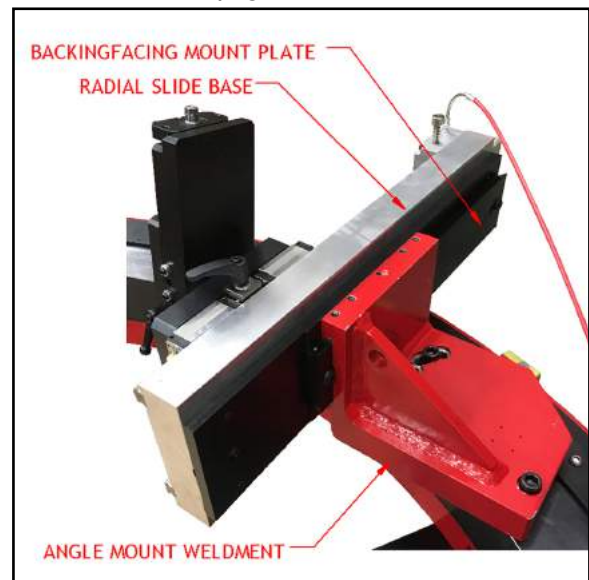

FIGURE 4-2. COMPOSANTS POUR FIXATION ARRIÈRE

2. Retirez le chariot coulissant radial de pont d'outil soudé et installez-le sur la plaque de montage pour fixation arrière.

3. Installez l'élément soudé de montage angulaire sur la machine à l'aide des trous de boulon spécifiques au modèle.
4. Installez le chariot coulissant axial sur l'élément soudé de montage angulaire.

4.3 FONCTIONNEMENT

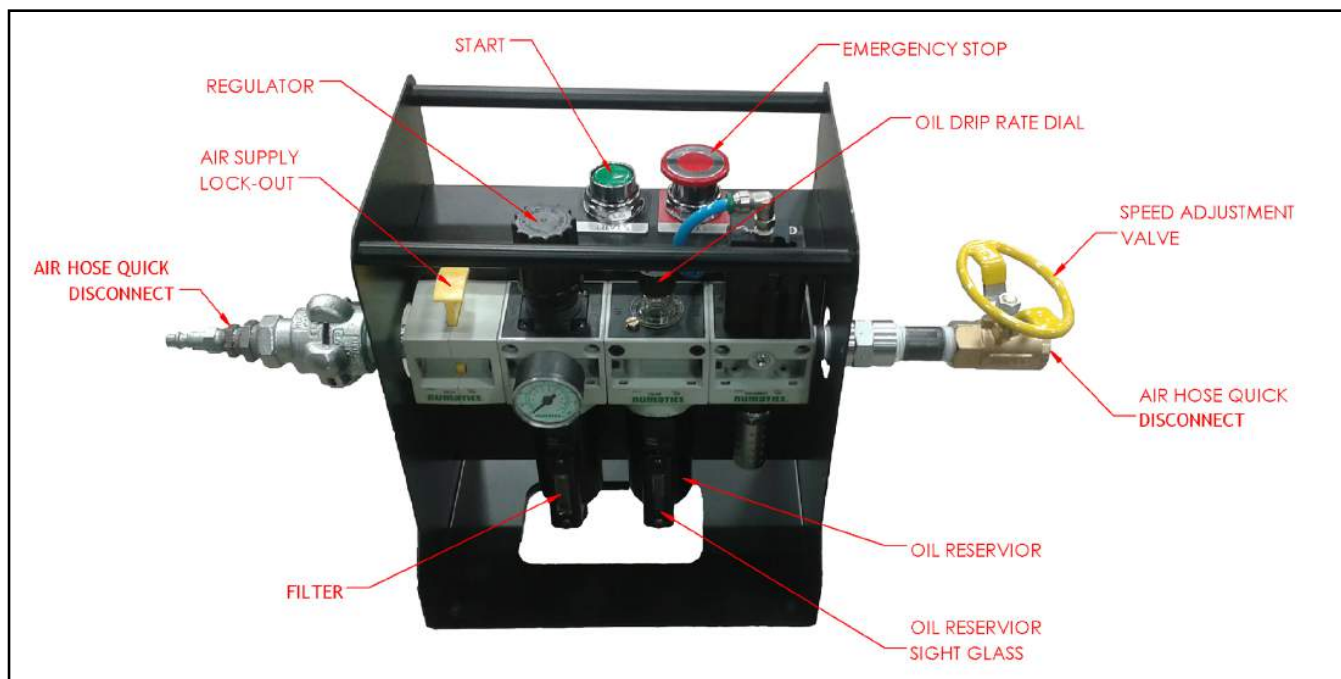

FIGURE 4-3. COMMANDES AIR CADDY

4.3.1 Démarrage de la machine

Procédez comme suit pour démarrer la machine :

1. Réalisez ces étapes sur l'Air Caddy (comme le montre la Figure 4-3) :
 - a) Ouvrez la SOUPAPE DE VERROUILLAGE DE L'AIR COMPRIMÉ (AIR SUPPLY LOCK-OUT).
 - b) Tirez le bouton d'ARRÊT D'URGENCE (EMERGENCY STOP) vers le haut.
 - c) Appuyez sur le bouton START.
 - d) Ouvrez lentement la SOUPAPE DE RÉGLAGE DE LA VITESSE (SPEED ADJUSTMENT) jusqu'à ce que la vitesse de rotation atteigne la vitesse désirée.
2. Embrayez le nombre de doigts d'embrayage requis pour le type de finition (voir Section 3.4.4, page 20).



FIGURE 4-4. VIS DE RÉGLAGE DE L'AVANCE ET BOUTON DE DIRECTION DE L'AVANCE

3. Ajustez la vitesse d'avance. Arrêtez la machine (voir Section 4.3.2, page 26) puis affinez la vis de réglage d'avance en fonction de la vitesse de coupe initiale.
4. Réglez la vitesse d'avance et la vitesse de rotation afin de conserver la coupe désirée.
5. Réglez le débit d'huile comme nécessaire (voir Figure 4-3).

AVIS

Pour obtenir les meilleures performances de la machine et une longue durée de vie, H&S recommande un débit d'huile minimum pour l'Air Caddy de six gouttes à la minute.

4.3.2 Arrêt de la machine

Procédez comme suit pour arrêter la ODF70 Speed Facer :

1. Débrayez les doigts d'embrayage (voir Figure 3-9, page 20).
2. Tournez la soupape de RÉGLAGE DE LA VITESSE (SPEED ADJUSTMENT) dans le sens horaire pour la fermer.

3. Appuyez sur la soupape de VERROUILLAGE DE L'AIR COMPRIMÉ (AIR SUPPLY LOCK-OUT) pour la fermer (voir Figure 4-3). Cette action libère la pression d'air résiduelle dans le circuit de l'Air Caddy.

4.3.3 Adaptation de la configuration de la machine

Procédez comme suit pour régler manuellement la position ou l'angle de l'outil de coupe :

1. Débrayez les doigts d'embrayage (voir Figure 4-4).
2. Arrêtez et verrouillez la machine (voir Section 4.3.2).
3. Réglez manuellement la position ou l'angle de l'outil de coupe (voir Section 3.4.1, page 18 et Section 3.4.2, page 19).

AVERTISSEMENT

N'essayez pas de régler manuellement l'angle de l'outil de coupe ou de modifier les réglages du module d'avance en fonctionnement. Tenter de faire fonctionner les commandes du module d'avance à la main ou avec des outils à main pendant que la machine fonctionne peut causer de graves blessures.

5 ENTRETIEN

DANS CE CHAPITRE :

| | |
|---|----|
| 5.1 LISTE DE VÉRIFICATION D'ENTRETIEN | 27 |
| 5.2 LUBRIFIANTS APPROUVÉS | 27 |
| 5.3 TÂCHES D'ENTRETIEN | 28 |
| 5.3.1 VÉRIFICATION DU RÉSERVOIR À HUILE ET DU PIÈGE DU FILTRE À PARTICULES DE L'AIR CADDY | 28 |
| 5.3.2 VÉRIFICATION DU CIRCUIT DE COUPURE DE L'AIR CADDY | 29 |
| 5.3.3 TEST DU BOUTON D'ARRÊT D'URGENCE | 29 |
| 5.3.4 PASSAGES QUEUE D'ARONDE | 29 |
| 5.3.4.1 PASSAGES QUEUE D'ARONDE RADIAUX | 29 |
| 5.3.4.2 PASSAGES QUEUE D'ARONDE AXIAUX | 29 |
| 5.3.5 INSTALLATION ET RETRAIT DU PROTECTEUR | 29 |
| 5.3.6 RÉGLAGE DES ROULEAUX | 30 |
| 5.4 DÉPANNAGE | 31 |
| 5.4.1 LA MACHINE NE TOURNE PAS | 31 |
| 5.4.2 LA MACHINE N'AVANCE PAS | 31 |
| 5.4.3 LES PERFORMANCES DE LA MACHINE SONT MÉDIOCRES | 31 |
| 5.4.4 LA COUPE DE LA MACHINE N'EST PAS PLATE | 31 |

5.1 LISTE DE VÉRIFICATION D'ENTRETIEN

Le Tableau 5-1 énumère les intervalles d'entretien et les tâches à réaliser

TABLEAU 5-1. INTERVALLES D'ENTRETIEN ET TÂCHES À RÉALISER

| Intervalle | Tâche | Référence |
|-----------------------------------|--|-----------|
| Avant chaque utilisation | Vérifier le réservoir à huile de l'Air Caddy et le piège du filtre à particules. | 5.3.1 |
| | Vérifier le bon état des lignes pneumatiques (détériorations, usure). | -- |
| | Vérifier l'affûtage de l'outil de coupe Remplacer si nécessaire. | 5.4.3 |
| | Vérifier le circuit de coupure du groupe de conditionnement pneumatique (Air Caddy). | 5.3.2 |
| Avant et après chaque utilisation | Enlever les débris, l'huile et l'humidité de la surface de la machine. | -- |
| Tous les cycles de fonctionnement | Lubrifier les passages queue d'aronde de l'avance axiale et radiale. | 5.3.4 |

5.2 LUBRIFIANTS APPROUVÉS

H&S préconise l'usage des lubrifiants suivants aux emplacements indiqués.

Ne pas utiliser les lubrifiants appropriés risque de causer des dommages et l'usure prématurée de la machine.

ATTENTION

Évitez la détérioration de la machine et son usure précoce. Protégez votre garantie en utilisant uniquement des lubrifiants agréés.

TABLEAU 5-2. LUBRIFIANTS APPROUVÉS

| Zone d'application | Lubrifiant | Lubrifiant biodégradable | Viscosité (cSt) | Quantité | Fréquence |
|---|--|--------------------------|-----------------------------------|---|--|
| Une fois par jour | | | | | |
| Passages rectangulaires et en queue d'aronde ^a | Mobil Vactra Oil Heavy Medium | n.d. | >68 @ 40 °C | Comme requis | Quotidiennement durant l'utilisation de la machine |
| À chaque utilisation | | | | | |
| Air Caddy | Unax AW 32 | n.d. | 22-68 @ 40 °C 4,3-8,7 @ 100 °C | Remplir le lubrificateur d'huile. | À chaque utilisation |
| Surfaces non peintes | LPS1 ou LPS2 | n.d. | 38 @ 25 °C | Comme requis | À chaque utilisation et avant stockage |
| Hebdomadaire | | | | | |
| Vis-mère sur la tête d'outil à point unique | Lubrifiant pour pulvérisateur NOOK E-100 Graisse NOOK PAG-1 | CASTROL BioTac EP 2 | 96 @ 40C 113 @ 100C | Fine couche appliquée à la main ou en spray | Hebdomadaire durant l'utilisation de la machine |
| Pieds de poussée | Anti-grippant Moly Grade Anti-Seize | n.d. | n.d. | 1 cc par vis | Toutes les semaines durant l'utilisation de la machine et avant stockage |
| Annuellement | | | | | |
| Surface de roulement de la bague de portée | LPS All-Purpose Anti-Seize Platinum Grade | n.d. | n.d. | Comme requis | Hebdomadaire durant l'utilisation de la machine |

a. Utilisez une huile minérale ou de synthèse, raffinée, hautement anticorrosive, apte à former un film d'huile puissant et qui ne soit pas facilement émulsifiée ni évacuée par un liquide de refroidissement. D'habitude, les huiles hydrauliques ne conviennent pas à la lubrification de glissières.

5.3 TÂCHES D'ENTRETIEN

Les tâches d'entretien sont décrites aux sections ci-après.

5.3.1 Vérification du réservoir à huile et du piège du filtre à particules de l'Air Caddy

Procédez comme suit pour vérifier le réservoir à huile et le piège du filtre à particules de l'Air Caddy :

1. Vérifiez le regard en verre du réservoir à huile de l'Air Caddy (voir Figure 4-3, page 25). Complétez si nécessaire.
de l'Air Caddy. Videz si nécessaire.
2. Vérifiez le regard du piège du filtre à particules

5.3.2 Vérification du circuit de coupure de l'Air Caddy

Le circuit de coupure du groupe de conditionnement pneumatique (Air Caddy) empêche la machine de redémarrer de manière imprévue après une perte d'alimentation en air comprimé et sa restauration.

Procédez comme suit pour vérifier le circuit de coupure de l'Air Caddy :

1. Vérifiez que l'Air Caddy est raccordé à l'alimentation en air de l'atelier et à la ODF70 Speed Facer.
2. Vérifiez que le verrouillage de l'alimentation en air est ouvert (tiré vers le haut). Voir Figure 4-3, page 25.
3. Appuyez sur le bouton START.
4. Ouvrez lentement la soupape de réglage de la vitesse de l'Air Caddy pendant que l'unité rotative embraye.
5. Fermez la soupape de VERROUILLAGE DE L'ALIMENTATION EN AIR (AIR SUPPLY LOCK-OUT) (en appuyant dessus).
6. Vérifiez que la ODF70 Speed Facer s'arrête.
7. Ouvrez la SOUPE DE VERROUILLAGE DE L'AIR COMPRIMÉ (AIR SUPPLY LOCK-OUT).
8. Vérifiez que la machine ne démarre pas.

5.3.3 Test du bouton d'arrêt d'urgence

Procédez comme suit pour tester le bouton d'arrêt d'urgence :

1. La machine étant en marche, appuyez sur le bouton d'ARRÊT D'URGENCE (EMERGENCY STOP).
2. Vérifiez que la machine s'arrête.
3. Réarmez le bouton d'ARRÊT D'URGENCE (EMERGENCY STOP) en tirant le bouton vers le haut.
4. Vérifiez que la machine ne redémarre pas.

5.3.4 Passages queue d'aronde

5.3.4.1 Passages queue d'aronde radiaux

Procédez comme suit pour effectuer l'entretien sur les passages queue d'aronde radiaux :

1. Sur le chariot coulissant, utilisez la vis d'avance radiale pour déplacer la tête d'outil vers une extrémité de la voie d'avance radiale.
2. Essuyez les passages queue d'aronde exposés et lubrifiez-les avec de l'huile glissière Mobil VACTRA medium heavy ou équivalente.
3. Déplacez l'ensemble de la tête d'outil vers l'autre extrémité de la voie d'avance radiale.

4. Essuyez les passages queue d'aronde exposés restants et lubrifiez-les avec de l'huile glissière Mobil VACTRA medium heavy ou équivalente.

5.3.4.2 Passages queue d'aronde axiaux

Procédez comme suit pour effectuer l'entretien sur les passages queue d'aronde axiaux :

1. Sur le chariot coulissant, utilisez la vis d'avance axiale pour déplacer la tête d'outil vers une extrémité de la voie d'avance axiale.
2. Essuyez les passages queue d'aronde exposés et lubrifiez-les avec de l'huile glissière Mobil VACTRA medium heavy ou équivalente.
3. Déplacez l'ensemble de la tête d'outil vers l'autre extrémité de la voie d'avance axiale.
4. Essuyez les passages queue d'aronde exposés restants et lubrifiez-les avec de l'huile glissière Mobil VACTRA medium heavy ou équivalente.

5.3.5 Installation et retrait du protecteur

Procédez comme suit pour retirer le dispositif protecteur pour des opérations d'entretien :

1. Dévissez toutes les vis M8 jusqu'à ce qu'elles soient dégagées des montants.
2. Repérez une vis M8 centrale sur l'une des sections de protection.
3. Placez l'extrémité fermée d'une clé polygonale 9/16 sur la tête de la vis selon un angle qui la saisisse contre le protecteur.



FIGURE 5-1. CLÉ POLYGONALE SUR LA VIS

4. Tirez rapidement la clé vers le haut et sortez-la pour retirer le protecteur.
5. Répétez l'step 2 et l' step 4 pour les autres sections de protecteur restantes.

Le travail d'entretien réalisé, procédez comme suit pour installer le protecteur :

1. Si elles sont encore en place, retirez toutes les vis M8 des sections du protecteur.

2. Placez la première section du protecteur en bonne position sur la machine.
3. Au centre du protecteur, insérez deux poinçons 3/16" (ou équivalent) dans les trous du protecteur dans les montants dessous. Il peut être nécessaire de commencer l'opération à une extrémité, plutôt qu'au centre, dans le cas des machines de plus grande largeur.



FIGURE 5-2. POINÇONS UTILISÉS POUR L'INSTALLATION DU PROTECTEUR

4. Levez les poinçons vers l'intérieur de la machine en tirant le protecteur pour le mettre en position. Frappez en même temps la face du protecteur avec un maillet souple.
5. Répétez les étapes 2 à 4 pour les autres sections de protecteur restantes.
6. Remettez toutes les vis M8 en place et serrez-les.

5.3.6 Réglage des rouleaux

Pendant le fonctionnement de la machine, chaque rouleau doit tourner environ les deux tiers du temps. Si les rouleaux sont réglés trop serrés, la machine se liera. Un réglage idéal permet de tourner la machine à la main.

AVERTISSEMENT

Le réglage des rouleaux requiert que la machine fonctionne sans protecteur mis en place. Ne tentez jamais de régler les rouleaux pendant que la machine est en rotation, ceci causerait de graves blessures, voire la mort.

Procédez comme suit pour régler les rouleaux :

1. Retirez tous les protecteurs (voir Section 5.3.5, page 29.)
2. Démarrez la machine et accélérez-la jusqu'à pleine vitesse de service.
3. Repérez les rouleaux qui ne tournent pas correctement.
4. Arrêtez la machine et appuyez sur la soupape de verrouillage de l'alimentation en air.
5. Placez la clé de réglage du rouleau (voir Figure 5-3) sur la douille excentrique et desserrez la vis de blocage avec une clé Allen de 5/16". Réglez la douille excentrique tel que le rouleau touche à peine la rainure dans la couronne dentée.



FIGURE 5-3. CLÉ DE RÉGLAGE DU ROULEAU (P/N 86988)

6. Serrez la vis de blocage en maintenant la position de la douille excentrique à l'aide de la clé de réglage.
7. Refaites le test de la machine à pleine vitesse de service.
8. Appliquez de l'anti-grippant sur la surface du roulement de la couronne dentée et des rouleaux comme le montre la Figure 5-2.
9. Remettez les protecteurs en place.

5.4 DÉPANNAGE

Cette section est destinée à vous aider à résoudre des problèmes de base de fonctionnement de la machine. Pour un entretien sérieux ou si vous avez des questions au sujet des procédures suivantes, contactez H&S.

5.4.1 La machine ne tourne pas

Si la machine ne tourne pas, vérifiez les points suivants :

1. La source d'alimentation électrique est connectée et mise sous tension.
2. Le bouton d'ARRÊT D'URGENCE (EMERGENCY STOP) est réarmé (Section 4.3.1, page 25 et Section 5.3.3, page 29).
3. Le régulateur d'air est ouvert et n'est pas défaillant (Figure 4-3, page 25).
4. De l'air sous pression entre et sort de l'Air Caddy. Contrôlez la pression d'air en débranchant les raccords rapides du tuyau et en contrôlant le purgeur d'air (Figure 4-3, page 25).
5. Toutes les soupapes sont ouvertes (Figure 4-3, page 25).
6. Tous les raccords rapides sont entièrement engagés (Figure 4-3, page 25).
7. Contrôlez le mouvement de la machine en vérifiant d'abord que l'alimentation de l'entraînement de la machine est isolée et verrouillée, puis en faisant pivoter la machine manuellement à l'aide des poignées sur le pont d'outil soudé.

5.4.2 La machine n'avance pas

Si la machine n'avance pas correctement, vérifiez les points suivants :

1. Les doigts d'embrayage sont embrayés (Section 3.4.4, page 20).
2. Le bouton de direction de l'avance est soit enfoncé ou sorti et non en position neutre centrale.

5.4.3 Les performances de la machine sont médiocres

Si la machine fait preuve de médiocres performances, vérifiez les points suivants :

1. L'outil est installé correctement (Section 3.4.2, page 19).
2. La machine est bien serrée sur la pièce d'usinage (Section 3.3, page 15).
3. Les vis du pont d'outil soudé sont bloquées.
4. Les vis de blocage sur les chariots coulissants radial et axial sont correctement ajustées (Section 4.2.1, page 23 et Section 4.2.2, page 24).
5. Les vis de serrage oscillantes sur la tête d'outil rotative sont serrées (Section 3.4.1, page 18).
6. L'outil de coupe ou l'insert est acéré et sa géométrie correspond au matériau et au type de coupe.
7. La vitesse et la vitesse d'avance sont correctement réglées. Si nécessaire, faites des essais avec des vitesses et des vitesses d'avance différentes. Normalement, les vitesses plus faibles et les coupes superficielles produisent moins de claquements d'outil.

5.4.4 La coupe de la machine n'est pas plate

Si la machine n'a pas une coupe plate, vérifiez les points suivants :

1. Avant de procéder à une passe d'écrobage cruciale, faites fonctionner la machine en continu pendant au moins 15 minutes pour vérifier que la machine a bien chauffé à la température de fonctionnement.
2. Vérifiez la mise à niveau de la machine Section 3.4.1, page 18.
3. Alignez le support d'outil sur la face de la bride si nécessaire (Section 3.4.1, page 18).

Cette page est laissée vierge intentionnellement

6 ENTREPOSAGE ET EXPÉDITION

DANS CE CHAPITRE :

| | |
|---|----|
| 6.1 ENTREPOSAGE - - - - - | 33 |
| 6.1.1 ENTREPOSAGE DE COURTE DURÉE - - - - - | 33 |
| 6.1.2 ENTREPOSAGE DE LONGUE DURÉE - - - - - | 33 |
| 6.2 EXPÉDITION - - - - - | 34 |
| 6.3 MISE HORS SERVICE - - - - - | 34 |

6.1 ENTREPOSAGE

AVERTISSEMENT

Si la machine n'est pas correctement fixée, elle risque de tomber et de causer des blessures mortelles au personnel. Portez une attention particulière aux installations à brides verticales et au-dessus de la tête. La machine doit être correctement arrimée et fixée à une grue ou tout autre appareillage de levage adéquat avant de commencer le désassemblage.

L'entreposage adéquat de la ODF70 Speed Facer prolongera sa durée de vie et préviendra tout dommage injustifié.

Avant l'entreposage, effectuez les actions suivantes :

1. Nettoyez la machine avec du solvant pour enlever toute graisse, copeaux métalliques et l'humidité.
2. Purgez le groupe de conditionnement pneumatique de tous les liquides.

Entreposez la ODF70 Speed Facer dans sa caisse d'expédition d'origine. Conservez tous les matériaux d'emballage afin de pouvoir emballer la machine de nouveau.

6.1.1 Entreposage de courte durée

Procédez comme suit pour préparer un stockage de courte durée (trois mois ou moins):

1. Retirez la tête d'outil de la pièce d'usinage.

2. Retirez l'outil.
3. Retirez les tuyaux.
4. Retirez la machine de la pièce d'usinage.
5. Nettoyez la machine pour retirer les salissures, la graisse, les copeaux métalliques et l'humidité.
6. Pulvérisez toutes les surfaces non recouvertes de peinture avec le produit LPS-2 pour prévenir la corrosion.
7. Entrez la ODF70 Speed Facer dans sa caisse d'expédition d'origine (voir Figure 6-1).

6.1.2 Entreposage de longue durée

Procédez comme suit pour préparer un stockage de longue durée (plus de trois mois) :

1. Suivez les instructions pour un entreposage de courte durée, mais utilisez du produit LPS-3 au lieu de LPS-2.
2. Ajoutez une poche de déshydratant dans le conteneur d'expédition. Remplacez-la conformément aux instructions du fabricant.
3. Entrez le conteneur d'expédition dans un environnement à l'abri des rayons du soleil à une température < 70 °F (21 °C) et une humidité < 50 %.

6.2 EXPÉDITION

La ODF70 Speed Facer peut être expédiée dans son conteneur d'expédition d'origine, comme le montre la Figure 6-1.

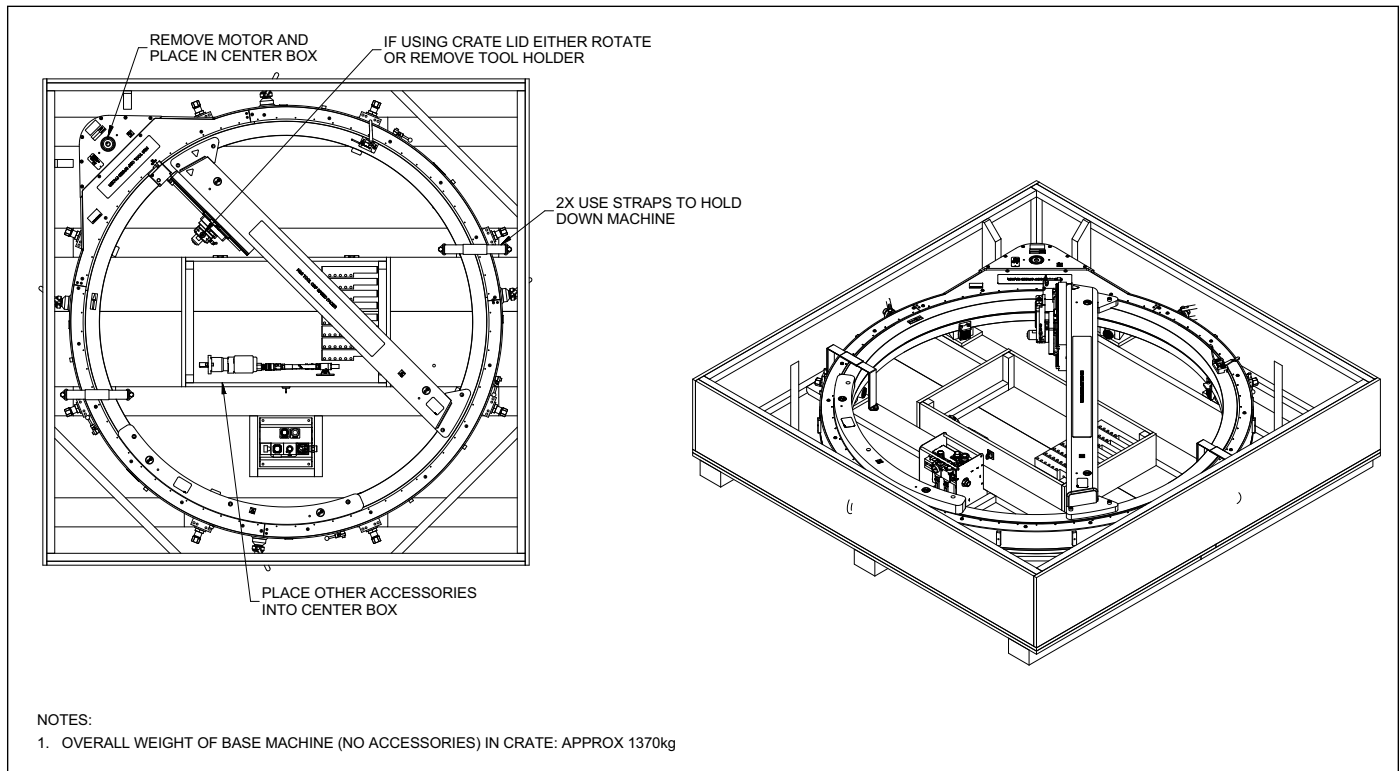

FIGURE 6-1. CAISSE DE LA ODF70

6.3 MISE HORS SERVICE

Pour la mise hors service de la ODF70 Speed Facer avant de la mettre au rebut, retirez le bloc d'entraînement et mettez-le au rebut séparément du reste des composants de la machine. Se reporter à l'Annexe A pour des informations sur l'ensemble du composant.

ANNEXE A DESSINS D'ASSEMBLAGE

Liste des dessins

| | |
|---|----|
| FIGURE A-1. ENSEMBLE ODF70 SPEED FACER (P/N 87000) - - - - - | 36 |
| FIGURE A-2. ÉTIQUETTES DE L'ENSEMBLE ODF70 SPEED FACER (P/N 87000) - - - - - | 37 |
| FIGURE A-3. LISTES DE PIÈCES DE L'ENSEMBLE ODF70 SPEED FACER (P/N 87000) - - - - - | 38 |
| FIGURE A-4. ENSEMBLE CHARIOT COULISSANT PORTE-OUTIL (P/N 79790) - - - - - | 39 |
| FIGURE A-5. LISTE DES PIÈCES ENSEMBLE CHARIOT COULISSANT PORTE-OUTIL - - - - - | 40 |
| FIGURE A-6. ENSEMBLE BLOC DE CONDITIONNEMENT PNEUMATIQUE (P/N 83430) - - - - - | 41 |
| FIGURE A-7. ENSEMBLE BLOC DE CONDITIONNEMENT PNEUMATIQUE (P/N 83430) - - - - - | 42 |
| FIGURE A-8. BLOC PIED DE POUSSÉE DE NIVELLEMENT (P/N 86880) - - - - - | 43 |
| FIGURE A-9. ENSEMBLE AXE RADIAL (P/N 86890) - - - - - | 44 |
| FIGURE A-10. LISTE DES PIÈCES ENSEMBLE AXE RADIAL (P/N 86890) - - - - - | 45 |
| FIGURE A-11. ENSEMBLE MODULE D'AVANCE À CÂBLE (P/N 86900) - - - - - | 46 |
| FIGURE A-12. ACTIONNEUR DE L'AVANCE DANS L'ENSEMBLE MODULE D'AVANCE À CÂBLE (P/N 86900) | 47 |
| FIGURE A-13. ENSEMBLE DOIGT D'EMBRAYAGE (P/N 86910) - - - - - | 48 |
| FIGURE A-14. BLOC DE PIED DE POUSSÉE SANS NIVELLEMENT (P/N 86970) - - - - - | 49 |
| FIGURE A-15. BLOC MOTEUR D'ENTRAÎNEMENT (P/N 86989) - - - - - | 50 |
| FIGURE A-16. ENSEMBLE PIED D'EXTENSION (P/N 87164) - - - - - | 51 |
| FIGURE A-17. ENSEMBLE FIXATION EN FACE ARRIÈRE (P/N 87310) - - - - - | 52 |
| TABLEAU A-1. KIT D'OUTILS P/N 78530 - - - - - | 53 |

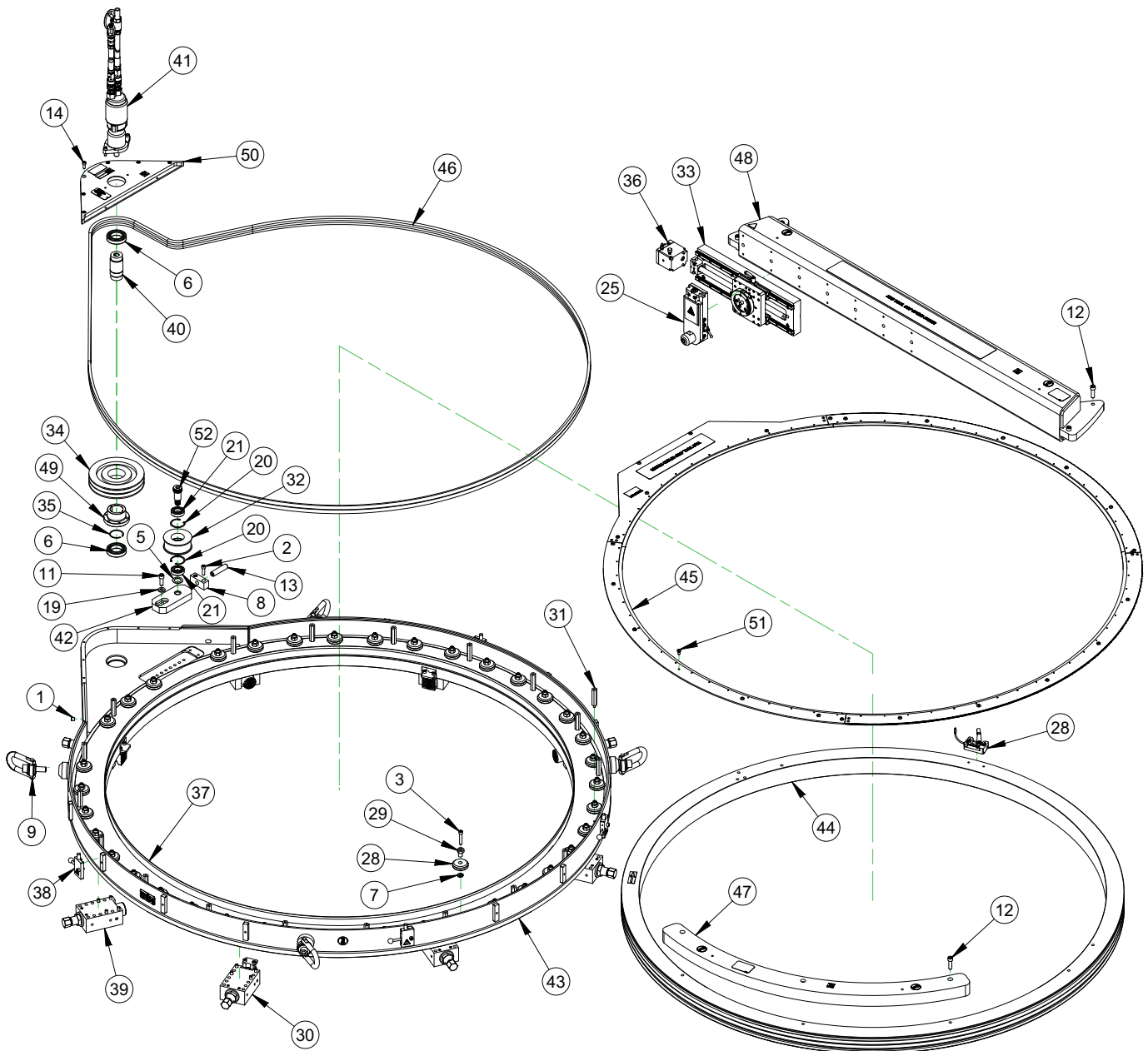

FIGURE A-1. ENSEMBLE ODF70 SPEED FACER (P/N 87000)

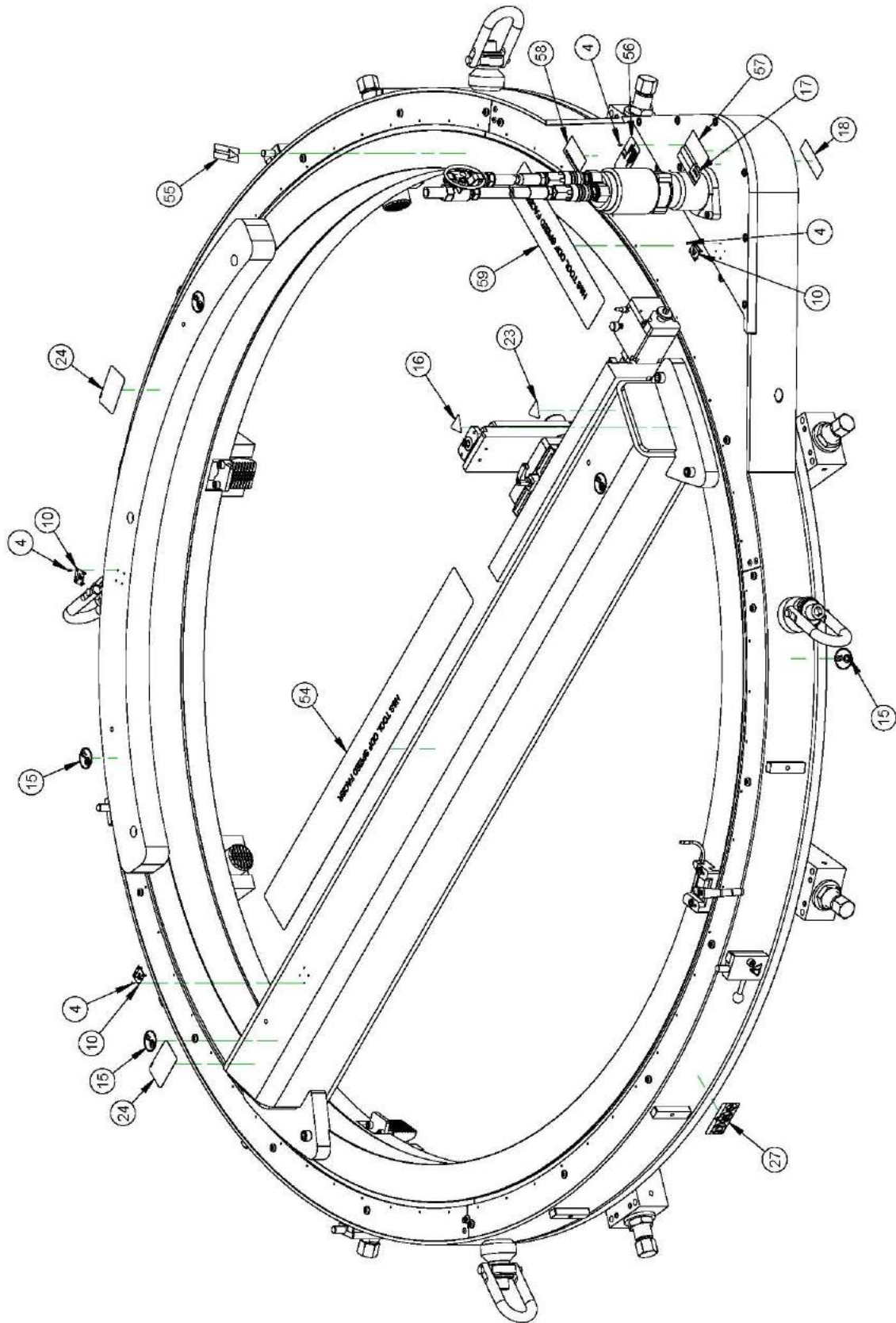

FIGURE A-2. ÉTIQUETTES DE L'ENSEMBLE ODF70 SPEED FACER (P/N 87000)

| PARTS LIST | | | | PARTS LIST | | | |
|------------|-----|-------|--|------------|-----|-------|---|
| ITEM | QTY | P/N | DESCRIPTION | ITEM | QTY | P/N | DESCRIPTION |
| 1 | 2 | 10445 | FTG PLUG 1/4 NPTM SOCKET | 28 | 38 | 86878 | ROLLER W4 |
| 2 | 2 | 10453 | SCREW 3/8-16 X 1-1/4 SHCS | 29 | 38 | 86879 | BUSHING ECCENTRIC SIZE 4 |
| 3 | 38 | 10557 | SCREW 3/8-16 X 2 SHCS | 30 | 4 | 86880 | ASSY JACKING FOOT LEVELING |
| 4 | 14 | 10588 | SCREW DRIVE #2 x 1/4 HOLE SIZE 089 | 31 | 19 | 86887 | POST 17MM HEX X 72MM M8 X 1.25 TAPPED AND THRD EACH END |
| 5 | 1 | 15079 | WASHER THRUST 1.000 ID X 1.562 OD X .030 | 32 | 1 | 86889 | IDLER TAKE UP ODF DRIVE |
| 6 | 2 | 16111 | BRG BALL 1.7717 ID X 2.9528 OD X .6299 SEALS | 33 | 1 | 86890 | ASSY RADIAL AXIS 356MM TRAVEL |
| 7 | 38 | 19236 | WASHER 3/8 FLTW HARDENED | 34 | 1 | 86894 | SHEAVE SIZE B 2 GROOVE 8.35 OD QD BORE |
| 8 | 1 | 20956 | BLOCK ADJUSTING | 35 | 1 | 86897 | RING SNAP 1.937 OD X .031 SINGLE TURN SPIRAL |
| 9 | 4 | 22814 | RING HOIST 3/4-10 X 1-1/2 5000 LB | 36 | 1 | 86900 | ASSY FEEDBOX PULL CABLE |
| 10 | 3 | 29152 | PLATE MASS CE | 37 | 223 | 86901 | SEAL STRIP .062" THICK X 3/8" WIDE |
| 11 | 1 | 30207 | SCREW M12 X 1.75 X 35mm SHCS | 38 | 4 | 86910 | ASSY FEED TRIPPER |
| 12 | 7 | 35215 | SCREW M12 X 1.75 X 40mm SHCS | 39 | 4 | 86970 | ASSY JACKING FOOT NON-LEVELING |
| 13 | 1 | 39513 | SCREW 3/4-10 X 3 SSSCP | 40 | 1 | 86972 | SHAFT ODF DRIVE |
| 14 | 6 | 50458 | SCREW M8 X 1.25 X 20mm SHCS | 41 | 1 | 86989 | ASSY ODF DRIVE MOTOR |
| 15 | 8 | 59039 | LABEL WARNING LIFT POINT ROUND 1.5" | 42 | 1 | 86998 | PLATE TAKE UP ODF DRIVE |
| 16 | 1 | 59042 | LABEL WARNING - HAND CRUSH/MOVING PARTS | 43 | 1 | 87001 | FRAME WELDMENT SF70 |
| 17 | 1 | 60219 | LABEL HOSE CONNECT SCHEME RED-RED/BLUE-BLUE | 44 | 1 | 87002 | RING TRACK SF70 |
| 18 | 1 | 60220 | LABEL HOSE CONNECT SCHEME BLUE-RED/RED-BLUE | 45 | 1 | 87003 | GUARD AND SEAL ASSY SF70 |
| 19 | 1 | 62978 | WASHER M12 FLTW 27MM OD 3.1 MM THICK | 46 | 2 | 87004 | BELT V 5VX2650 |
| 20 | 2 | 67743 | RING SNAP 2.0 ID X .062 TH | 47 | 1 | 87006 | COUNTERWEIGHT SF70 |
| 21 | 2 | 67910 | BRG BALL 1.000 ID X 2.000 OD X .500 2 SEALS | 48 | 1 | 87007 | WELDMENT BRIDGE ODF70 |
| 22 | 1 | 78530 | (NOT SHOWN) TOOL KIT SF SERIES | 49 | 1 | 87008 | BUSHING QD SK 1-15/16 |
| 23 | 1 | 79324 | LABEL WARNING - HAND ENTANGLEMENT/ROTATING GEARS 1.13 TALL TRIANGLE YELLOW | 50 | 1 | 87019 | PLATE COVER DRIVE SF70 |
| 24 | 2 | 79385 | LABEL WARNING - LIFT SUB ASSY ONLY GRAPHIC 2 X 3 | 51 | 26 | 87020 | SCREW M8 X 1.25 X 15MM BHCS CAPTIVE 10 THD STAINLESS |
| 25 | 1 | 79790 | ASSY SLIDE TOOL HOLDER | 52 | 1 | 87022 | SCREW 1 DIA X 1.5 X 3/4-10 SHLDCS |
| 26 | 1 | 83430 | (NOT SHOWN) PNEUMATIC CONDITIONING UNIT W/SHEET METAL STAND | 53 | 1 | 87149 | (NOT SHOWN) CRATE ODF70 92 X 92 X 21-1/4 3/4 PLY |
| 27 | 2 | 84856 | LABEL DANGER - ODF TETHER MACHINE BEFORE USE | 54 | 1 | 87262 | LABEL H&S ODF70 LOGO 3.5 X 33.0 |
| | | | | 55 | 1 | 87265 | LABEL ARROW BLK/YEL 1" X 3" |
| | | | | 56 | 1 | 87269 | PLATE SERIAL YEAR MODEL BLANK CE 1.5 X 3.0 |
| | | | | 57 | 1 | 87271 | LABEL WARNING - EYE EAR MANUAL PROTECTION 1-3/8 X 2-3/4 |
| | | | | 58 | 1 | 87272 | LABEL MADE IN THE U.S.A 1.5" X 2.5" |
| | | | | 59 | 1 | 87430 | LABEL H&S ODF40 LOGO 3.0 X 14.0 |

FIGURE A-3. LISTES DE PIÈCES DE L'ENSEMBLE ODF70 SPEED FACER (P/N 87000)

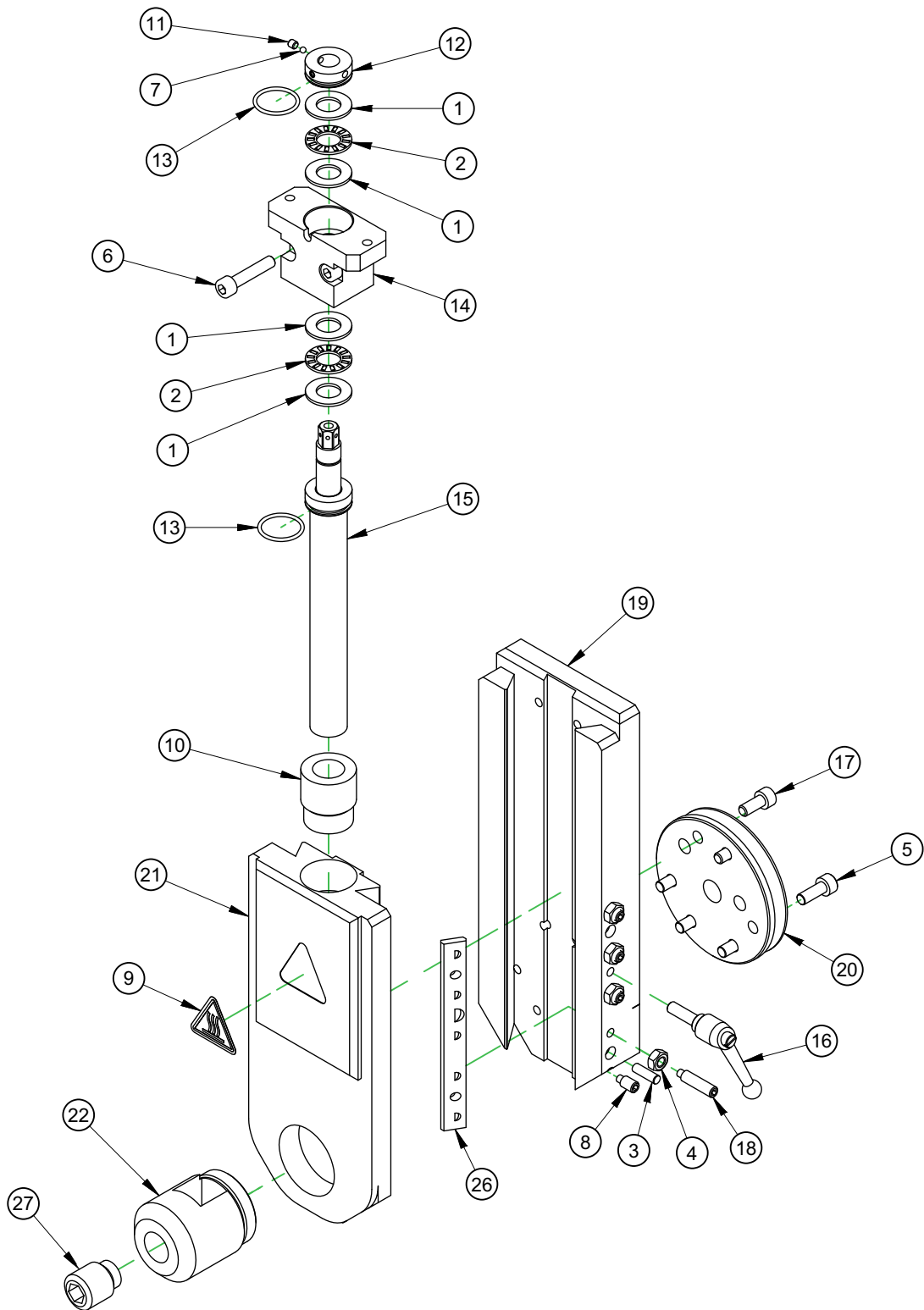

FIGURE A-4. ENSEMBLE CHARIOT COULISSANT PORTE-OUTIL (P/N 79790)

| PARTS LIST | | | |
|------------|-----|-------|--|
| ITEM | QTY | P/N: | DESCRIPTION |
| 1 | 4 | 10436 | WASHER THRUST .500 ID X .937 OD X .060 |
| 2 | 2 | 10437 | BRG THRUST .500 ID X .937 OD X .0781 |
| 3 | 2 | 16953 | PIN DOWEL 3/16 DIA X 5/8 |
| 4 | 4 | 20772 | NUT M6 X 1.0 STDN ZINC PLATED |
| 5 | 4 | 35014 | SCREW M6 X 1.0 X 16mm SHCS |
| 6 | 2 | 35505 | SCREW M6 X 1.0 X 30 SHCS |
| 7 | 2 | 43489 | BALL NYLON 1/8 DIA |
| 8 | 1 | 45034 | SCREW M6 X 1.0 X 12MM SSSDPPL |
| 9 | 1 | 46902 | LABEL WARNING HOT SURFACE GRAPHIC 1.13" TALL |
| 10 | 1 | 48526 | NUT LEADSCREW ACME 3/4-10 BRONZE LH |
| 11 | 2 | 53365 | SCREW M4 X 0.7 X 4 mm SSSFP |
| 12 | 1 | 57214 | BRG RETAINING NUT AXIAL FEED LEADSCREW |
| 13 | 2 | 57320 | RING O 1/16 X 13/16 ID X 15/16 OD |
| 14 | 1 | 57793 | BEARING BLOCK LEADSCREW |
| 15 | 1 | 57912 | LEAD SCREW AXIAL FEED FF LINE |
| 16 | 1 | 58133 | HANDLE ADJUSTABLE M6 X 1 X 20MM |
| 17 | 2 | 59003 | SCREW M6 X 1.0 X 14MM SHCS |
| 18 | 4 | 74658 | SCREW M6 X 1 X 25MM SSSDP |
| 19 | 1 | 79548 | BASE TOOL HOLDER |
| 20 | 1 | 79826 | PLATE DOVE CIRCULAR |
| 21 | 1 | 80307 | TOOL HEAD TOP SLIDE |
| 22 | 1 | 80309 | CLAMP TOOL BIT 3/4 SQ |
| 23 | AR | 80419 | (NOT SHOWN) SHIM 1.8 ID X 3.2 OD .001 THICK |
| 24 | AR | 80420 | (NOT SHOWN) SHIM 1.8 ID X 3.2 OD .002 THICK |
| 25 | AR | 80421 | (NOT SHOWN) SHIM 1.8 ID X 3.2 OD .005 THICK |
| 26 | 1 | 82224 | GIB TOOLHEAD |
| 27 | 1 | 82280 | SCREW M20 X 2.5 X 25MM SSSDP |

FIGURE A-5. LISTE DES PIÈCES ENSEMBLE CHARIOT COULISSANT PORTE-OUTIL

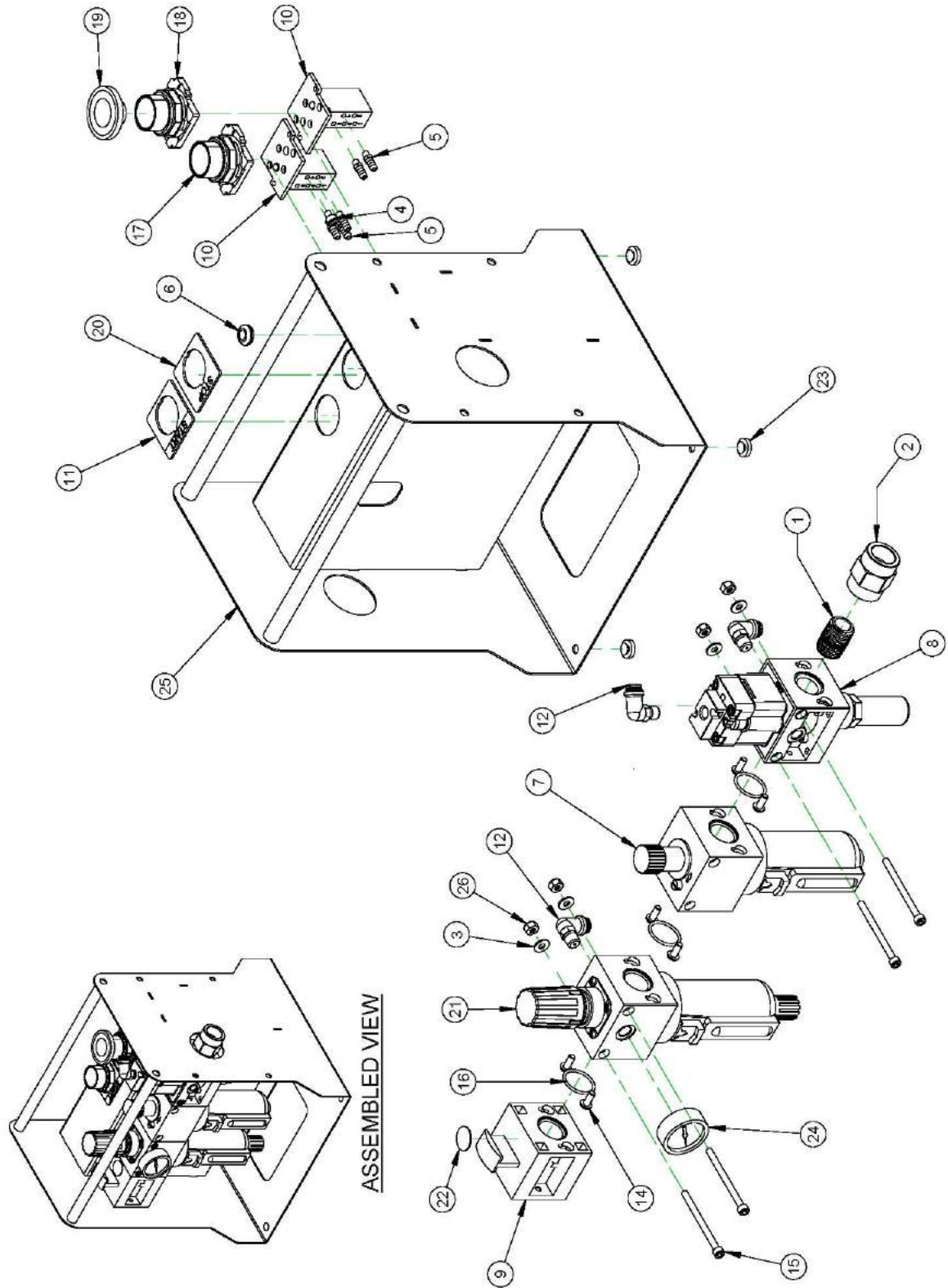
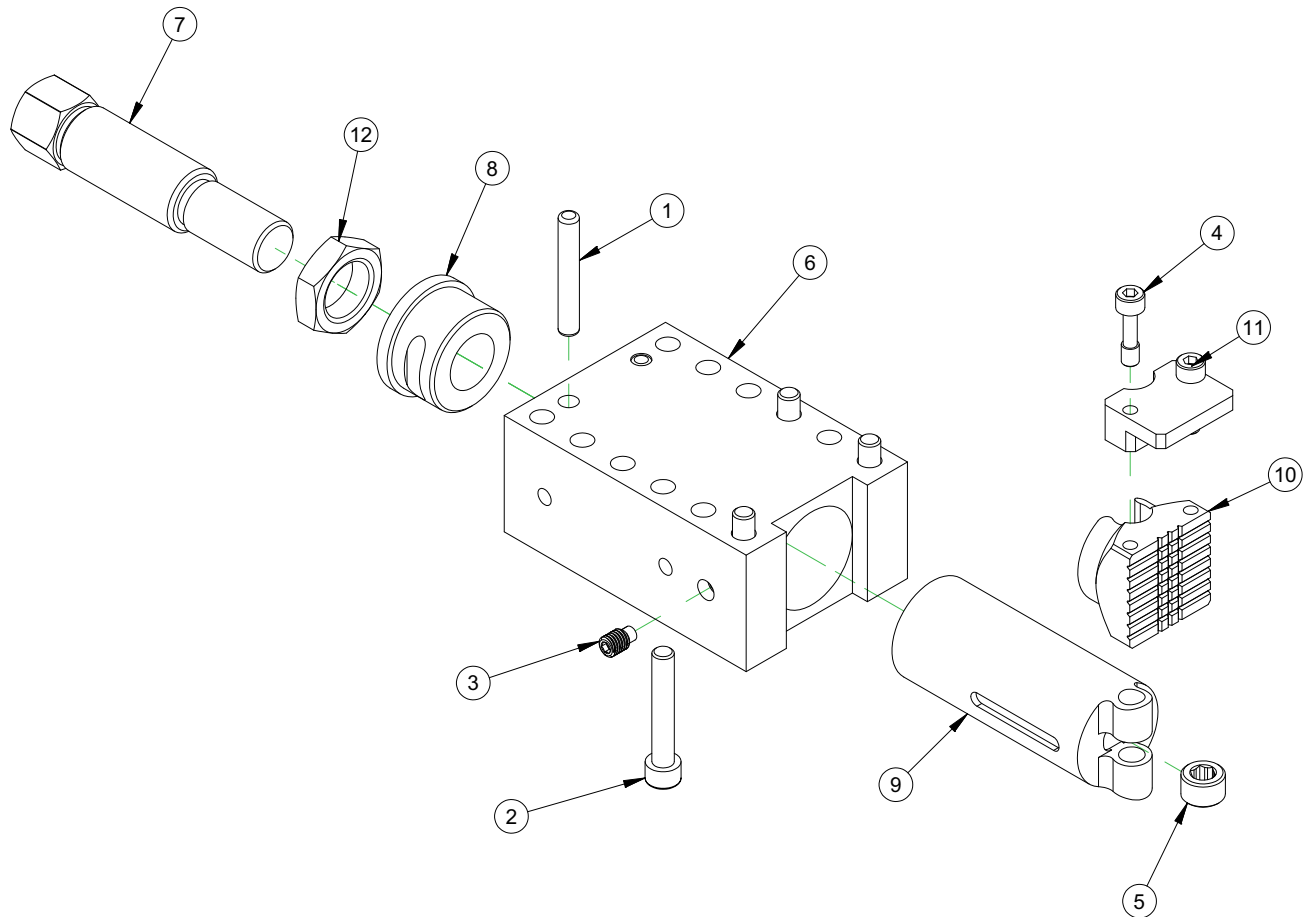

FIGURE A-6. ENSEMBLE BLOC DE CONDITIONNEMENT PNEUMATIQUE (P/N 83430)

| PARTS LIST | | | |
|------------|-----|-------|---|
| ITEM | QTY | P/N: | DESCRIPTION |
| 1 | 1 | 10223 | FTG NIPPLE CLOSE 1/2 NPTM X 1/2 NPTM 125 PSI 1-1/8 LONG |
| 2 | 1 | 10319 | FTG COUPLING 1/2 NPTF X 1/2 NPTF STEEL ZINC PLATED |
| 3 | 4 | 11315 | WASHER #10 FLTW BLACK OXIDE |
| 4 | 1 | 14726 | SCREW 10-32 X 1/4 SHCS |
| 5 | 5 | 22235 | FTG BARB #10-32 X 1/8 HOSE |
| 6 | 1 | 40588 | GROMMET 5/8 OD 5/16 ID |
| 7 | 1 | 46768 | LUBRICATOR AIR 1/2 NPTF 3.8OZ BOWL W/SIGHT |
| 8 | 1 | 46769 | VALVE EXHAUST QUICK PILOT 1/2NPTF MUFFLER |
| 9 | 1 | 46777 | VALVE SHUT OFF VS22 SERIES |
| 10 | 2 | 46785 | VALVE PUSHBUTTON 5 PORT PNEUMATIC |
| 11 | 1 | 46797 | LEGEND PLATE START 10250 SERIES |
| 12 | 3 | 48648 | FTG ELBOW 1/8 NPTM X 1/4 TUBE PRESTOLOK |
| 13 | 28 | 48650 | (NOT SHOWN) TUBING 1/4 OD POLYURETHANE |
| 14 | 6 | 53617 | SCREW M5 X 0.8 X 12MM BHCS BLACK FINISH |
| 15 | 4 | 56357 | SCREW 10-24 X 2.5 SHCS |
| 16 | 3 | 59442 | RING O 2mm X 23mm ID X 25mm OD |
| 17 | 1 | 59458 | PUSHBUTTON GREEN FLUSH |
| 18 | 1 | 59459 | PUSH BUTTON PUSH PULL MAINTAINED (M-M) |
| 19 | 1 | 59462 | PUSH BUTTON OPERATOR RED 1-5/8 |
| 20 | 1 | 59825 | LEGEND PLATE STOP 10250SERIES YELLOW BACKGROUND |
| 21 | 1 | 78054 | FILTER/REGULATOR PARTICULATE 1/2NPTF METAL BOWL GLASS |
| 22 | 1 | 81132 | LABEL WARNING - INSERT SAFETY LOCK |
| 23 | 4 | 83462 | RUBBER BUMPER, 9/16 DIA X 1/8 TALL |
| 24 | 1 | 83486 | PRESSURE GAUGE, 0-160 PSI, 1/8 NPT CENTER BACK MOUNT |
| 25 | 1 | 87223 | STAND PCU |
| 26 | 4 | 87533 | NUT 10-24 STDNYLOC SS |

FIGURE A-7. ENSEMBLE BLOC DE CONDITIONNEMENT PNEUMATIQUE (P/N 83430)



| PARTS LIST | | | |
|------------|-----|-------|---|
| ITEM | QTY | P/N: | DESCRIPTION |
| 1 | 2 | 14297 | PIN DOWEL 3/8 DIA X 2-1/2 |
| 2 | 4 | 45754 | SCREW M10 x 1.5 x 60mm SHCS |
| 3 | 1 | 48998 | SCREW M10 X 1.5 X 16mm SSSHDP |
| 4 | 2 | 74632 | SCREW M8 X 1.25 X 30 OAL X 10 THD L STAINLESS |
| 5 | 1 | 80430 | SCREW MODIFIED M20 X 1.5 X 12.7MM HOLLOW LOCK |
| 6 | 1 | 86881 | HOUSING JACKING FOOT |
| 7 | 1 | 86882 | SCREW JACKING FOOT |
| 8 | 1 | 86883 | BUSHING THD 1-1/4-7 |
| 9 | 1 | 86884 | RAM JACKING LEVELING |
| 10 | 1 | 86885 | JAW JACKING LEVELING |
| 11 | 1 | 86886 | SETUP FINGER |
| 12 | 1 | 86908 | NUT 1-1/4-7 JAMN 1/2 THICK |

FIGURE A-8. BLOC PIED DE POUSSÉE DE NIVELLEMENT (P/N 86880)

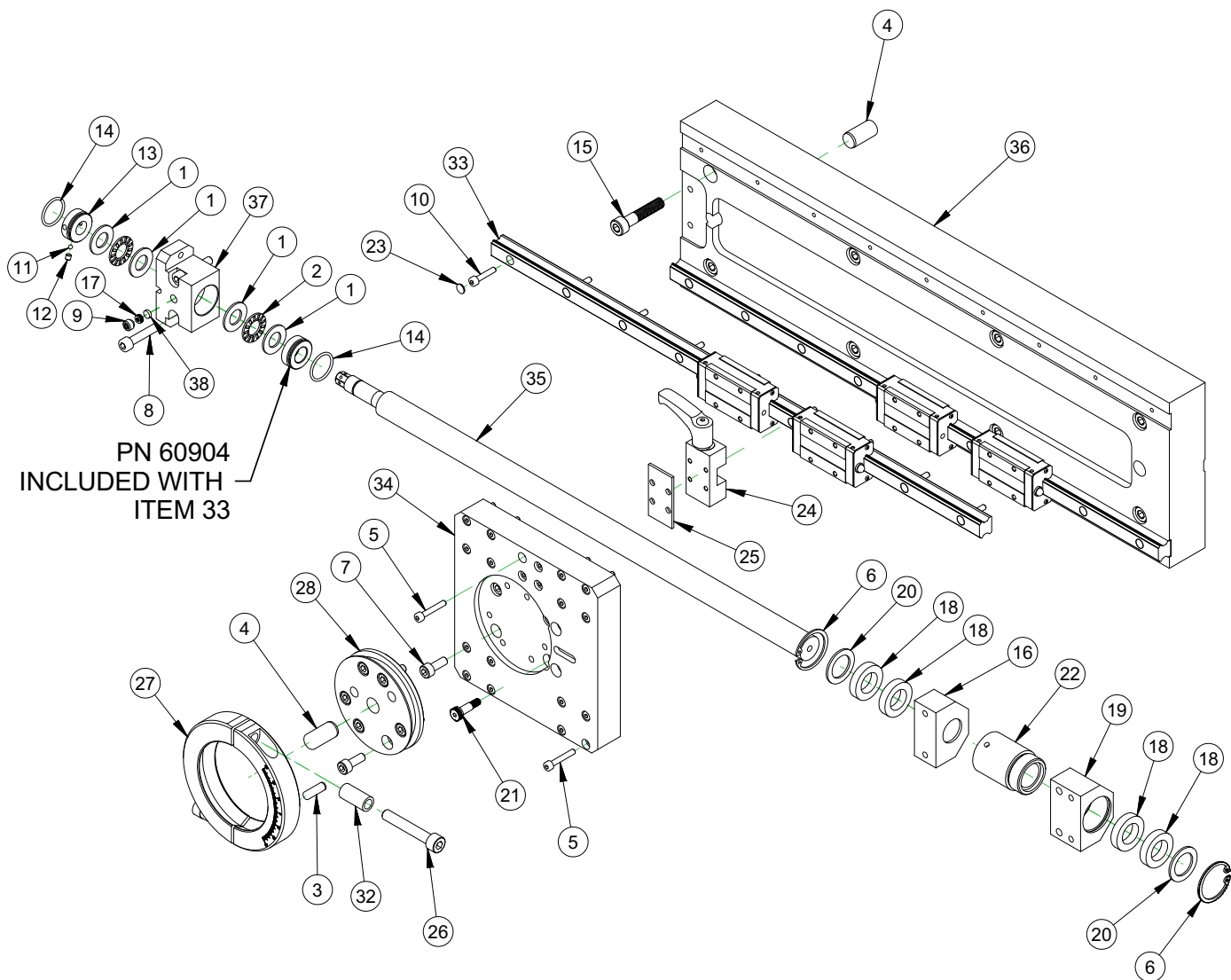
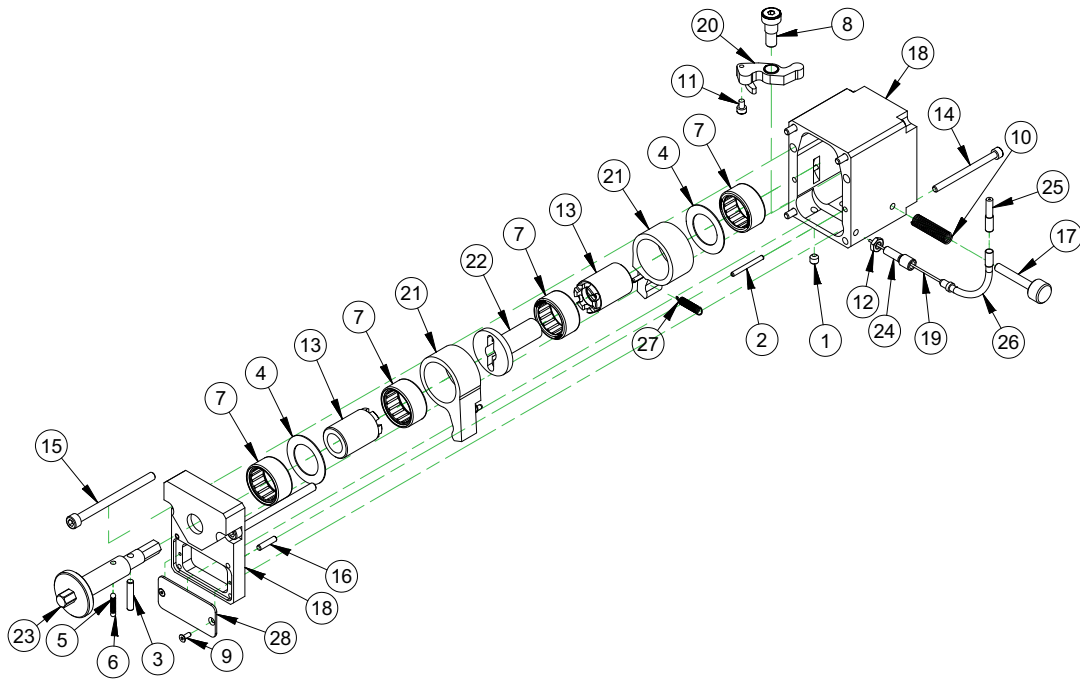

FIGURE A-9. ENSEMBLE AXE RADIAL (P/N 86890)

| PARTS LIST | | | |
|------------|-----|-------|---|
| ITEM | QTY | P/N: | DESCRIPTION |
| 1 | 4 | 10436 | WASHER THRUST .500 ID X .937 OD X .060 |
| 2 | 2 | 10437 | BRG THRUST .500 ID X .937 OD X .0781 |
| 3 | 1 | 11729 | PIN DOWEL 1/4 DIA X 3/4 |
| 4 | 3 | 20398 | PIN DOWEL 1/2 DIA X 1 |
| 5 | 20 | 22572 | SCREW M4 X 0.7 X 25mm SHCS |
| 6 | 2 | 33777 | RING SNAP 1-3/16 ID (30MM) |
| 7 | 10 | 35014 | SCREW M6 X 1.0 X 16mm SHCS |
| 8 | 2 | 35505 | SCREW M6 X 1.0 X 30 SHCS |
| 9 | 1 | 36087 | SCREW M8 X 1.25 X 6MM SSSFP |
| 10 | 18 | 38061 | SCREW M4 X 0.7 X 20 SHCS |
| 11 | 2 | 43489 | BALL NYLON 1/8 DIA |
| 12 | 2 | 53365 | SCREW M4 X 0.7 X 4 mm SSSFP |
| 13 | 1 | 57214 | BRG RETAINING NUT AXIAL FEED LEADSCREW |
| 14 | 2 | 57320 | RING O 1/16 X 13/16 ID X 15/16 OD |
| 15 | 8 | 61225 | SCREW M8 X 1.25 X 40MM SHCS |
| 16 | 1 | 62321 | HOLDER FELT WIPER MILLING HEAD |
| 17 | 6 | 62376 | WASHER SPRING BELLEVILLE 1/8 ID X 1/4 OD X .013 THK |
| 18 | 4 | 62379 | SEAL FELT 16MM BALL SCREW 1.015 OD MILLING HEAD |
| 19 | 1 | 62423 | MOUNT BALL NUT MILLING HEAD |
| 20 | 2 | 62903 | WASHER SHIM .75 ID 1.125 OD .062 THICK STEEL |
| 21 | 2 | 62909 | SCREW 6MM DIA X 12MM X M5 X 0.8 SHLDCS |
| 22 | 1 | 62960 | BALL SCREW NUT 20MM X 5MM LEAD LEFT HAND 33 MM OD EICHENBERGER ROUND |
| 23 | 18 | 68500 | CAP RAIL 15MM METAL THK SHS |
| 24 | 1 | 72636 | ZIMMER BRAKE 15MM RAIL |
| 25 | 1 | 72637 | ZIMMER ADAPTER 15MM RAIL |
| 26 | 2 | 72753 | SCREW M8 X 1.25 X 50MM SHCS |
| 27 | 1 | 79793 | CLAMP COLLAR |
| 28 | 1 | 79826 | PLATE DOVE CIRCULAR |
| 29 | AR | 80419 | (NOT SHOWN) SHIM 1.8 ID X 3.2 OD .001 THICK |
| 30 | AR | 80420 | (NOT SHOWN) SHIM 1.8 ID X 3.2 OD .002 THICK |
| 31 | AR | 80421 | (NOT SHOWN) SHIM 1.8 ID X 3.2 OD .005 THICK |
| 32 | 2 | 82226 | COLLAR 8MM ID X 12MM OD X 25MM |
| 33 | 2 | 86891 | SLIDE RAIL THK SHS15 520MM LG PRELOADED METAL SCRAPERS 2 SHORT BLOCKS |
| 34 | 1 | 86892 | PLATE RADIAL SADDLE |
| 35 | 1 | 86895 | BALL SCREW 20MM DIA SF RADIAL AXIS |
| 36 | 1 | 86896 | PLATE RADIAL AXIS BASE |
| 37 | 1 | 86898 | BEARING BLOCK BALLSCREW |
| 38 | 1 | 87033 | PAD POLYURETHANE 1/4 DIA X .08 THICK |

FIGURE A-10. LISTE DES PIÈCES ENSEMBLE AXE RADIAL (P/N 86890)



PARTS LIST

| ITEM | QTY | P/N: | DESCRIPTION |
|------|-----|-------|--|
| 1 | 1 | 10464 | SCREW 1/4-20 X 1/4 SSSCP |
| 2 | 2 | 11884 | PIN DOWEL 1/8 DIA X 1-1/4 |
| 3 | 1 | 14284 | PIN DOWEL 3/16 DIA X 1 |
| 4 | 2 | 15079 | WASHER THRUST 1.000 ID X 1.562 OD X .030 |
| 5 | 1 | 19561 | SPRING COMP .148 OD X .023 WIRE X .50 LONG STAINLESS |
| 6 | 2 | 19562 | BALL STEEL 5/32 DIA |
| 7 | 4 | 25957 | BRG ROLLER CLUTCH 1 X 1.312 X .625 |
| 8 | 1 | 29286 | SCREW 3/8 X 3/8 X 5/16-18 SHLDCS |
| 9 | 2 | 35876 | SCREW M3 X .5 X 8MM FHSCS |
| 10 | 1 | 36148 | SPRING COMP .36 OD X .032 WIRE X 1.25 LONG |
| 11 | 1 | 36152 | SCREW M4 X 0.7 X 6mm SHCS |
| 12 | 1 | 43019 | NUT M6 X 1.0 JAMN ZINC PLATED |
| 13 | 2 | 44721 | DRIVE BUSHING |
| 14 | 4 | 56357 | SCREW 10-24 X 2.5 SHCS |
| 15 | 2 | 59057 | SCREW M6 X 1.0 X 80 mm SHCS CL12.9 ZINC COATED |
| 16 | 2 | 60165 | PIN DOWEL 5/32 DIA X 11/16 |
| 17 | 1 | 76599 | SCREW M6 X 1.0 X 40MM KNURLED HEAD |
| 18 | 1 | 86899 | HOUSING FEEDBOX PULL CABLE |
| 19 | 1 | 86905 | CABLE BRAKE PULL 1.5MM |
| 20 | 1 | 86909 | PIVOT LINK PULL CABLE FEED |
| 21 | 2 | 86973 | CLUTCH ARM PULL CABLE FEED |
| 22 | 1 | 86978 | COUPLING FLANGED 3/8 INTERNAL HEX |
| 23 | 1 | 86979 | SHAFT PULL CABLE FEED BOX |
| 24 | 1 | 87038 | BOLT ADJUSTING M6 5MM BRAKE CABLE |
| 25 | A/R | 87181 | HOUSING 5MM DIA BRAKE CABLE |
| 26 | 1 | 87198 | BEND 90 DEG BRAKE CABLE |
| 27 | 2 | 87528 | SPRING EXT .18 OD X .023 WIRE X 1-1/4 |
| 28 | 1 | 87535 | COVER FEEDBOX PULL CABLE |

FIGURE A-11. ENSEMBLE MODULE D'AVANCE À CÂBLE (P/N 86900)

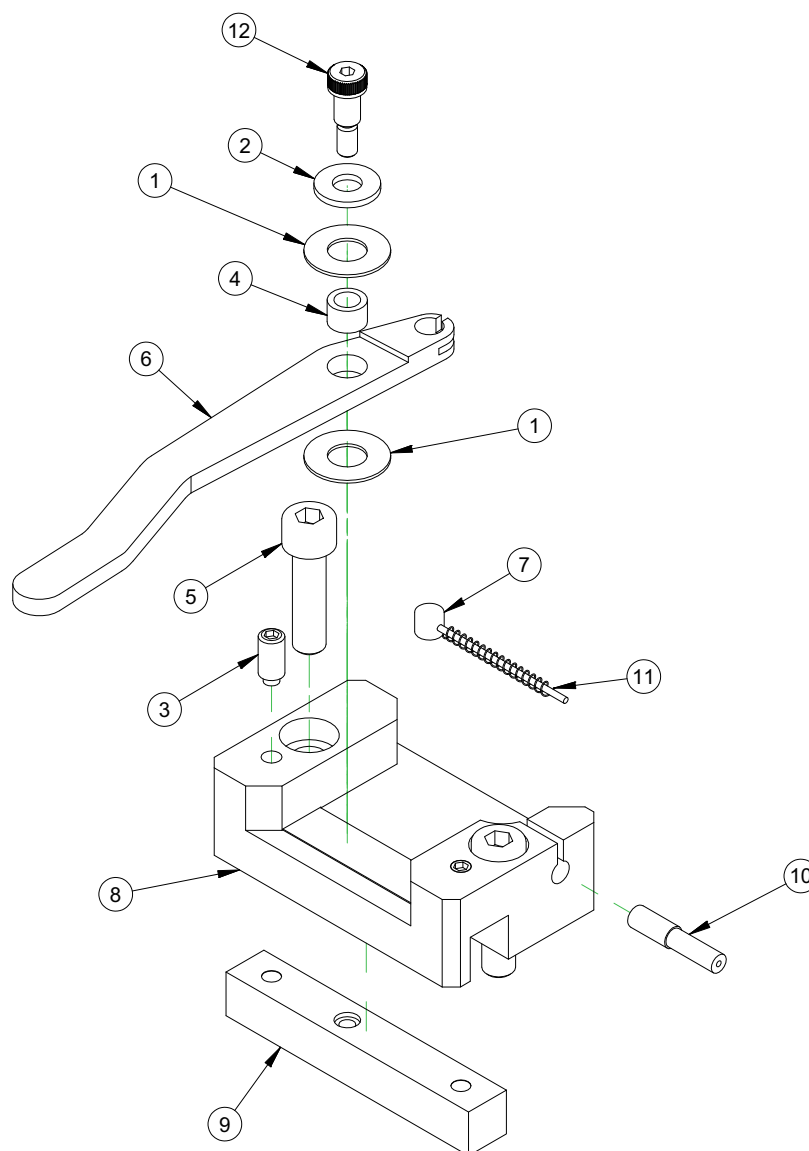

| PARTS LIST | | | |
|------------|-----|-------|---|
| ITEM | QTY | P/N: | DESCRIPTION |
| 1 | 2 | 10058 | WASHER THRUST .375 ID X .812 OD X .032 |
| 2 | 1 | 10702 | WASHER 1/4 FLTW SAE |
| 3 | 2 | 10848 | PLUNGER DETENT SPRING STUBBY 1/4-20 X .531 |
| 4 | 1 | 15259 | BUSHING OILITE 1/4 ID X 3/8 OD X 1/4 |
| 5 | 2 | 45530 | SCREW M8 X 1.25 X 30mm SHCS |
| 6 | 1 | 86904 | TRIP ARM CABLE FEED |
| 7 | 1 | 86905 | CABLE BRAKE PULL 1.5MM X 1700MM |
| 8 | 1 | 86906 | BLOCK FEED TRIP ACTUATOR |
| 9 | 1 | 86907 | KEY PIVOT PULL CABLE FEED |
| 10 | A/R | 87181 | HOUSING 5MM DIA BRAKE CABLE |
| 11 | 1 | 87529 | SPRING COMP .136 OD X .010 WIRE X 1.34 LONG |
| 12 | 1 | 87532 | SCREW 1/4 DIA X 3/8 X 10-32 SHLDCS |

FIGURE A-12. ACTIONNEUR DE L'AVANCE DANS L'ENSEMBLE MODULE D'AVANCE À CÂBLE (P/N 86900)

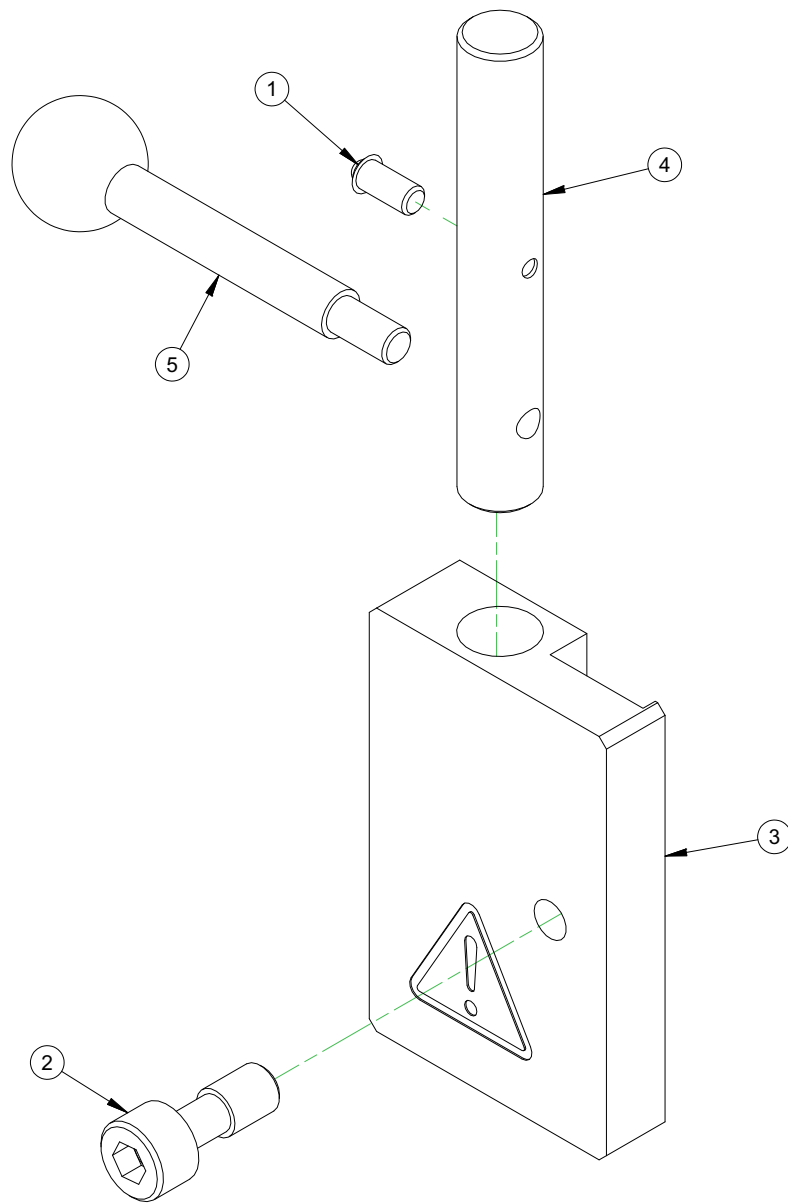

| PARTS LIST | | | |
|------------|-----|-------|--|
| ITEM | QTY | P/N: | DESCRIPTION |
| 1 | 1 | 26828 | PLUNGER BALL PUSHFIT |
| 2 | 1 | 84563 | SCREW M8 X 1.25 X 20MM SHCS CAPTIVE 10 THD STAINLESS |
| 3 | 1 | 86902 | BLOCK FEED TRIP |
| 4 | 1 | 86903 | ROD FEED TRIP |
| 5 | 1 | 87023 | LEVER M6 X 1.0 X 63MM ROUND RED HANDLE |

FIGURE A-13. ENSEMBLE DOIGT D'EMBRAYAGE (P/N 86910)

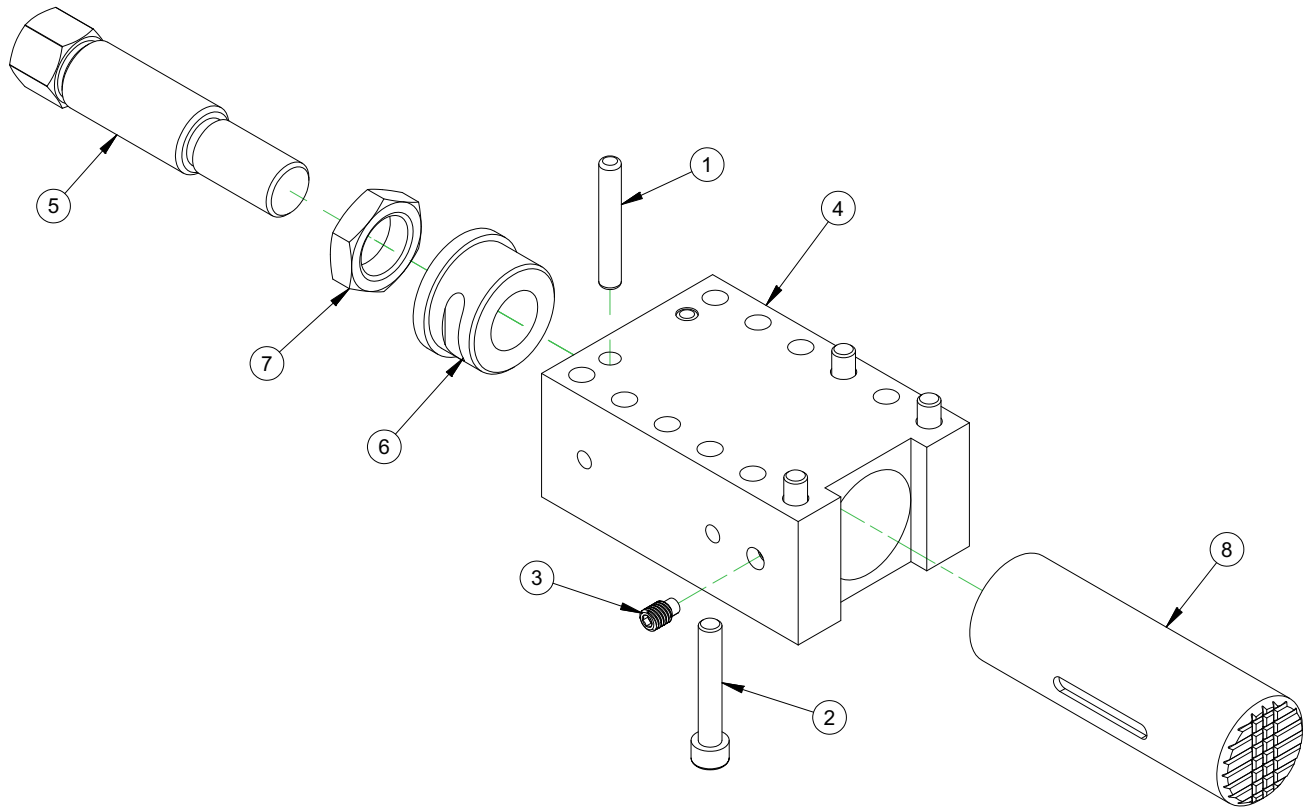

| PARTS LIST | | | |
|------------|-----|-------|-------------------------------|
| ITEM | QTY | P/N: | DESCRIPTION |
| 1 | 2 | 14297 | PIN DOWEL 3/8 DIA X 2-1/2 |
| 2 | 4 | 45754 | SCREW M10 x 1.5 x 60mm SHCS |
| 3 | 1 | 48998 | SCREW M10 X 1.5 X 16mm SSSHDP |
| 4 | 1 | 86881 | HOUSING JACKING FOOT |
| 5 | 1 | 86882 | SCREW JACKING FOOT |
| 6 | 1 | 86883 | BUSHING THD 1-1/4-7 |
| 7 | 1 | 86908 | NUT 1-1/4-7 JAMN 1/2 THICK |
| 8 | 1 | 86971 | RAM JACKING NON-LEVELING |

FIGURE A-14. BLOC DE PIED DE POUSSÉE SANS NIVELLEMENT (P/N 86970)

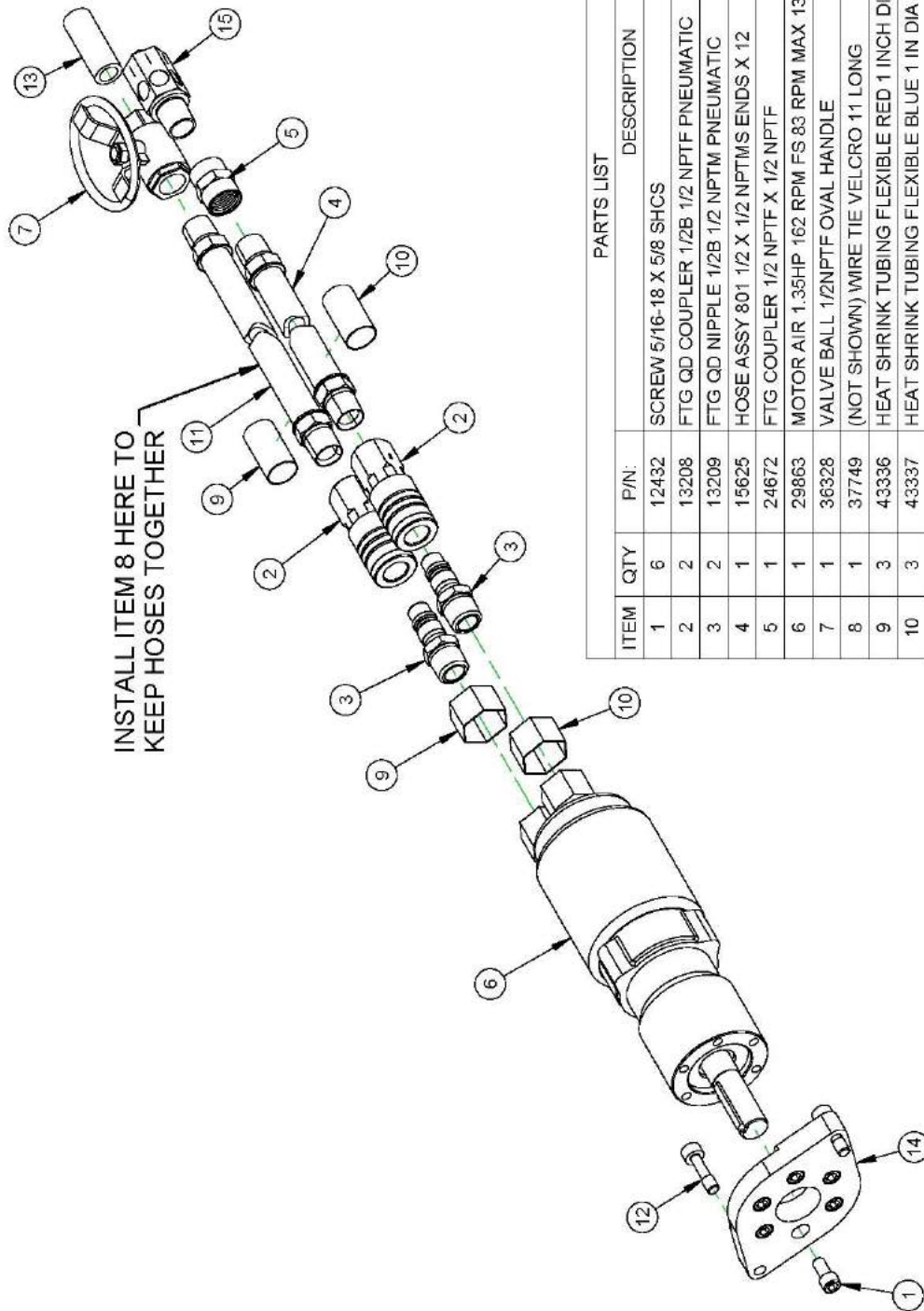

| ITEM | | QTY | P/N: | DESCRIPTION |
|------|---|-------|--|-------------|
| 1 | 6 | 12432 | SCREW 5/16-18 X 5/8 SHCS | |
| 2 | 2 | 13208 | FTG QD COUPLER 1/2B 1/2 NPTF PNEUMATIC | |
| 3 | 2 | 13209 | FTG QD NIPPLE 1/2B 1/2 NPTM PNEUMATIC | |
| 4 | 1 | 15625 | HOSE ASSY 801 1/2 X 1/2 NPTMS ENDS X 12 | |
| 5 | 1 | 24672 | FTG COUPLER 1/2 NPTF X 1/2 NPTF | |
| 6 | 1 | 29863 | MOTOR AIR 1.35HP 162 RPM FS 83 RPM MAX 134TQ REVERSE ROTATION | |
| 7 | 1 | 36328 | VALVE BALL 1/2NPTF OVAL HANDLE | |
| 8 | 1 | 37749 | VALVE BALL 1/2NPTF OVAL HANDLE (NOT SHOWN) WIRE TIE VELCRO 11 LONG | |
| 9 | 3 | 43336 | HEAT SHRINK TUBING FLEXIBLE RED 1 INCH DIA | |
| 10 | 3 | 43337 | HEAT SHRINK TUBING FLEXIBLE BLUE 1 IN DIA | |
| 11 | 1 | 59376 | HOSE ASSY 801 1/2 X 1/2 NPTMS ENDS X 180 | |
| 12 | 2 | 74632 | SCREW M8 X 1.25 X 30 OAL X 10 THD L STAINLESS | |
| 13 | 1 | 76030 | FTG NIPPLE 1/2 NPTM X 2 INCH BRASS | |
| 14 | 1 | 86893 | PLATE AIR MOTOR MOUNT | |
| 15 | 1 | 87263 | FTG MUFFLER EXHAUST FLOW CONTROL 1/2 NPTM | |

FIGURE A-15. BLOC MOTEUR D'ENTRAÎNEMENT (P/N 86989)

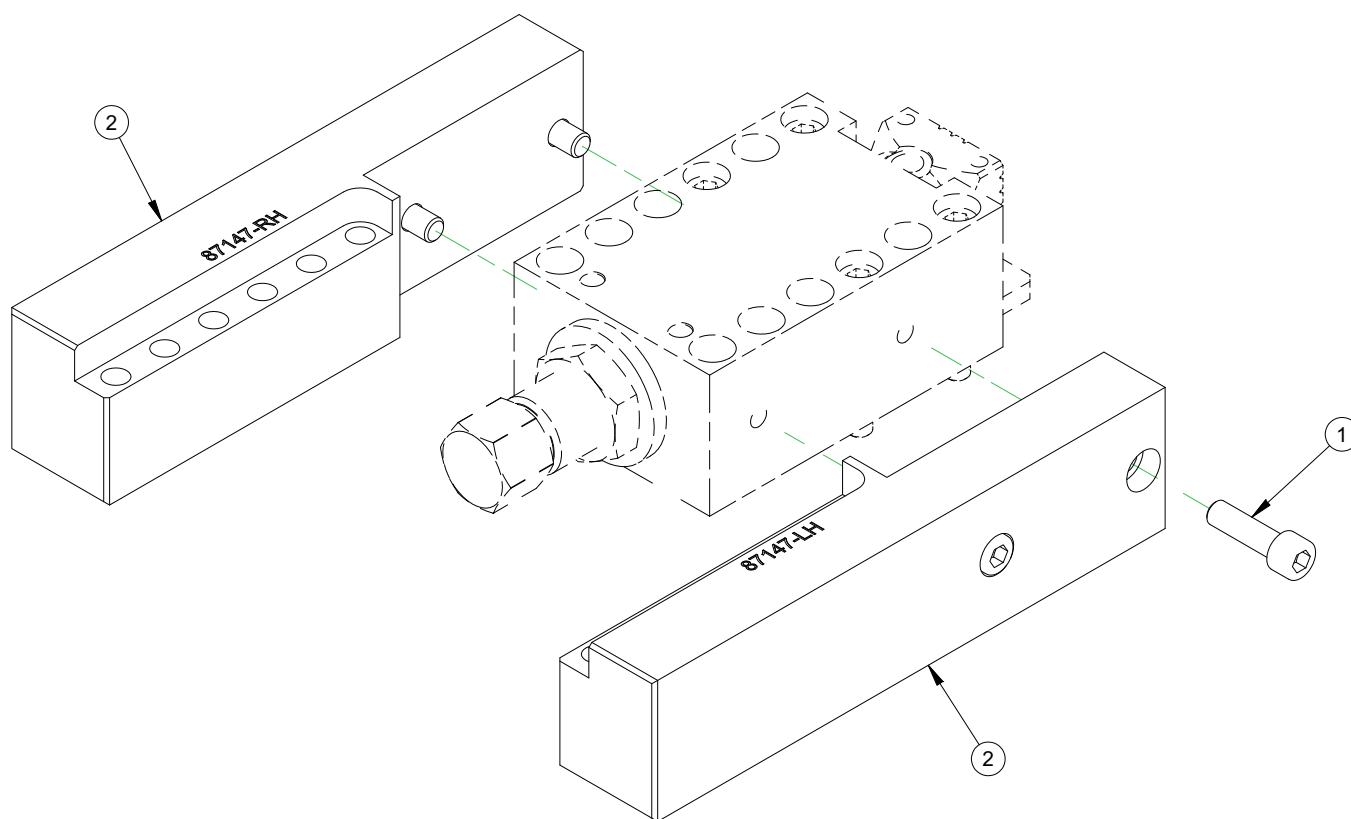

| PARTS LIST | | | |
|------------|-----|-------|------------------------------------|
| ITEM | QTY | P/N: | DESCRIPTION |
| 1 | 4 | 36079 | SCREW M10 X 1.5 X 35mm SHCS |
| 2 | 1 | 87147 | BAR SF MOUNTING FOOT EXTENSION SET |

FIGURE A-16. ENSEMBLE PIED D'EXTENSION (P/N 87164)

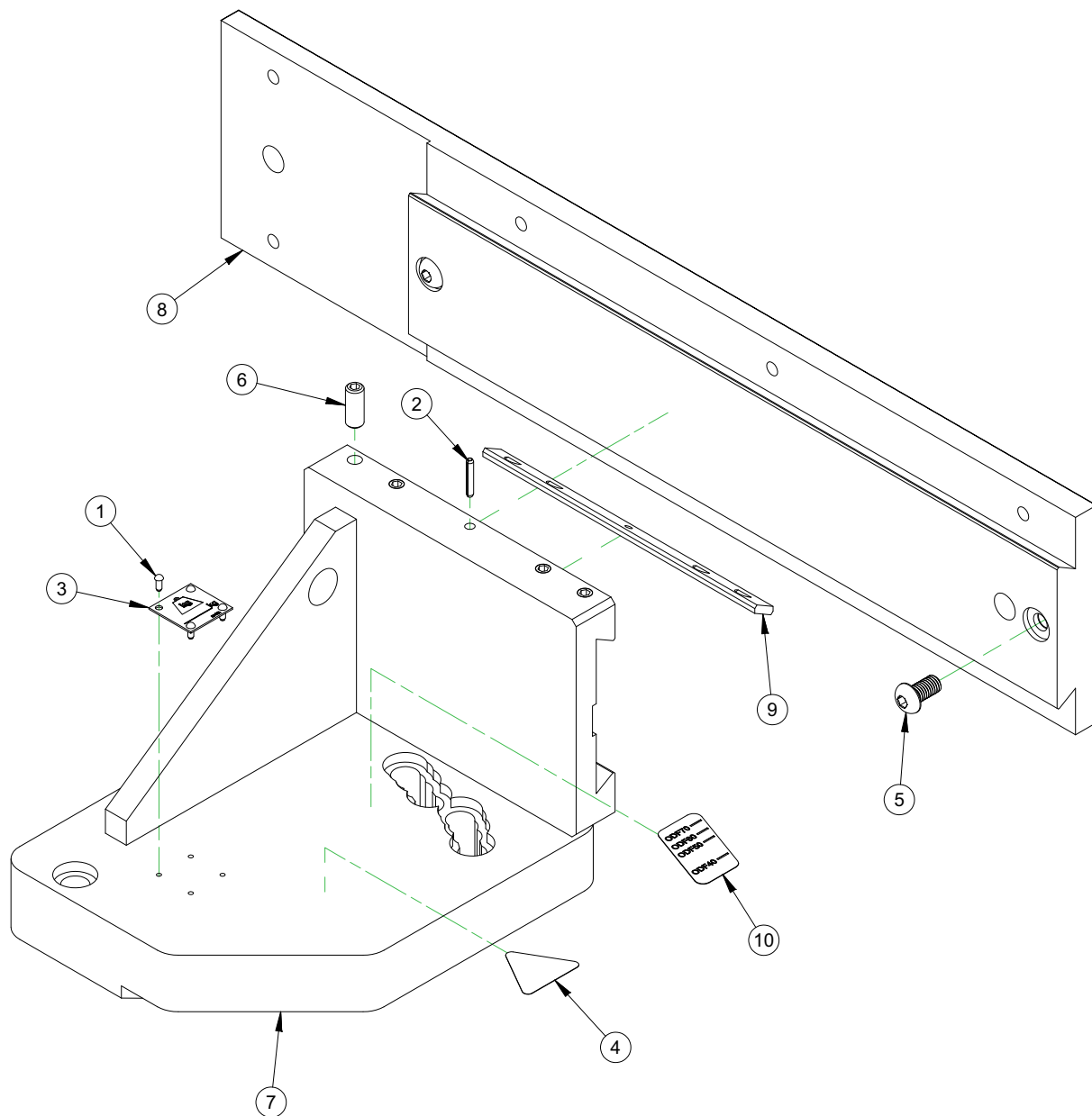

| PARTS LIST | | | |
|------------|-----|-------|---|
| ITEM | QTY | P/N: | DESCRIPTION |
| 1 | 4 | 10588 | SCREW DRIVE #2 x 1/4 HOLE SIZE .089 |
| 2 | 1 | 10847 | PIN ROLL 1/8 DIA X 3/4 |
| 3 | 1 | 29152 | PLATE MASS CE |
| 4 | 1 | 59042 | LABEL WARNING - HAND CRUSH/MOVING PARTS |
| 5 | 2 | 59827 | SCREW M8 X 1.25 X 16MM BHSCS |
| 6 | 4 | 83708 | SCREW M8 X 1.25 X 20 SSSFP |
| 7 | 1 | 87308 | WELDMENT BACKFACING ANGLE MOUNT |
| 8 | 1 | 87309 | PLATE BACKFACING MOUNT |
| 9 | 1 | 87416 | GIB .435 X .156 X 6.5 0-1 4 SS W/ DOWEL |
| 10 | 1 | 87425 | LABEL ODF BACKFACING LOCATING |

FIGURE A-17. ENSEMBLE FIXATION EN FACE ARRIÈRE (P/N 87310)

TABLEAU A-1. KIT D'OUTILS P/N 78530

| N° pièce | Description | Quantité |
|----------|---|----------|
| 14818 | CLÉ À CLIQUET, EMBOUT 1/2 | 1 |
| 31158 | DOUILLE CLÉ HEXA 5/8 X 1/2 (KB) | 1 |
| 35516 | MAILLET SOUPLE, DIAMÈTRE TÊTE 1-3/4 (KB) | 1 |
| 35821 | CLÉ HEXA 6MM X 6 POIGNÉE EN T | 1 |
| 38678 | SET CLÉS HEXA 1.5 - 10MM ROTULE D'EMBOUT BONDHUS (KB) | 1 |
| 39694 | CLÉ TORX FT-15 | 1 |
| 40806 | CLÉ HEXA 5/16 X 6 T POIGNÉE EN T | 1 |
| 41471 | ANNEAU DE LEVAGE 3/8-16 X .56 1.3 ID 2.18 OD 3.79 OAL 1000 LBS PIVOTANT | 2 |
| 46250 | DOUILLE CLÉ HEXA 10MM X 1/2 | 1 |
| 46251 | DOUILLE CLÉ HEXA 8MM X 1/2 | 1 |
| 48373 | COMBINAISON CLÉS 1-5/8 12PT | 1 |
| 55924 | CLÉ POUR TÉ 3/8 HEXA (KB) | 1 |
| 58354 | EXTENSION CLÉ, EMBOUT 1/2 X 5 | 1 |
| 86612 | DOUILLE DE CLÉ, EMBOUT 1-1/4 X 1/2; PROF. 12 PT | 1 |
| 86988 | DOUILLE DE CLÉ 7/8 AVEC POIGNÉE | 1 |
| 87266 | PLAQUETTE CARBURE 55 DEG DIAMANT IC8250 | 5 |
| 87267 | PORTE-PLAQUETTE 55 DEG DIAMANT 3/4 TIGE LR | 1 |
| 87268 | PORTE-PLAQUETTE 55 DEG DIAMANT 3/4 TIGE NEUTRE | 1 |

Cette page est laissée vierge intentionnellement

ANNEXE B N° FDS

Liste des FDS

| | | | |
|--|----|--|-----|
| LPS 1..... | 57 | Anti-grippant Moly Grade Anti-Seize..... | 91 |
| LPS 2..... | 66 | Nook E-100..... | 95 |
| Anti-grippant LPS All-Purpose Anti-Seize ... | 75 | Nook PAG-1..... | 102 |
| Huile Mobil Vactra Oil Heavy Medium..... | 81 | Unax AW 32..... | 110 |

Cette page est laissée vierge intentionnellement



SAFETY DATA SHEET

1. Identification

| | |
|---|--|
| Product identifier | LPS® 1 (Aerosol) |
| Other means of identification | |
| Part Number | 00116 |
| Recommended use | An industrial lubricant designed to displace moisture from mechanical and electrical equipment, provide light-duty lubrication and short-term rust prevention. |
| Recommended restrictions | None known. |
| Manufacturer/Importer/Supplier/Distributor information | |
| Manufacturer | |
| Manufacturer | |
| Company name | LPS Laboratories, a division of Illinois Tool Works, Inc. |
| Address | 4647 Hugh Howell Rd. Tucker, GA 30084 (U.S.A.) |
| Country | (U.S.A.) |
| In Case of Emergency | Tel: +1 770-243-8800 1-800-424-9300 (inside U.S.) +001 703-527-3887 (outside U.S.) |
| Website | www.lpslabs.com |
| E-mail | sds@lpslabs.com |

2. Hazard(s) identification

| | | |
|------------------------------|---|-----------------------------|
| Physical hazards | Flammable aerosols | Category 1 |
| | Gases under pressure | Compressed gas |
| Health hazards | Skin corrosion/irritation | Category 2 |
| | Sensitization, skin | Category 1B |
| | Specific target organ toxicity, single exposure | Category 3 narcotic effects |
| Environmental hazards | Not classified. | |
| OSHA defined hazards | Not classified. | |
| Label elements | | |



| | |
|--|--|
| Signal word | Danger |
| Hazard statement | Extremely flammable aerosol. Contains gas under pressure; may explode if heated. Causes skin irritation. May cause an allergic skin reaction. May cause drowsiness or dizziness. |
| Precautionary statement | |
| Prevention | Keep away from heat/sparks/open flames/hot surfaces. - No smoking. Do not spray on an open flame or other ignition source. Pressurized container: Do not pierce or burn, even after use. Avoid breathing gas. Wash thoroughly after handling. Use only outdoors or in a well-ventilated area. Contaminated work clothing must not be allowed out of the workplace. Wear protective gloves. |
| Response | If on skin: Wash with plenty of water. Take off contaminated clothing and wash before reuse. Specific treatment (see this label). If skin irritation or rash occurs: Get medical advice/attention. If inhaled: Remove person to fresh air and keep comfortable for breathing. Call a poison center/doctor if you feel unwell. |
| Storage | Store in a well-ventilated place. Keep container tightly closed. Store locked up. Protect from sunlight. Do not expose to temperatures exceeding 50°C/122°F. |
| Disposal | Dispose of contents/container in accordance with local/regional/national/international regulations. |
| Hazard(s) not otherwise classified (HNOC) | None known. |
| Supplemental information | None. |

Material name: LPS® 1 (Aerosol)
802 Version #: 01 Issue date: 10-01-2014

SDS US
1 / 9

3. Composition/information on ingredients

Mixtures

| Chemical name | Common name and synonyms | CAS number | % |
|---|--------------------------|------------|---------|
| Distillates Petroleum, Hydrotreated Light | | 64742-47-8 | 70 - 80 |
| Distillates Petroleum Hydrotreated Med | | 64742-46-7 | 10 - 20 |
| Carbon Dioxide | | 124-38-9 | 1 - 5 |
| Sorbitan trioleate | | 26266-58-0 | 1 - 3 |
| Calcium Sulfonate | | 61789-86-4 | 0.1 - 1 |

4. First-aid measures

| | |
|---|--|
| Inhalation | Remove victim to fresh air and keep at rest in a position comfortable for breathing. Call a POISON CENTER or doctor/physician if you feel unwell. |
| Skin contact | Remove contaminated clothing immediately and wash skin with soap and water. In case of eczema or other skin disorders: Seek medical attention and take along these instructions. Wash contaminated clothing before reuse. |
| Eye contact | Immediately flush eyes with plenty of water for at least 15 minutes. Remove contact lenses, if present and easy to do. Continue rinsing. Get medical attention if irritation develops and persists. |
| Ingestion | In the unlikely event of swallowing contact a physician or poison control center. Rinse mouth. Do not induce vomiting without advice from poison control center. If vomiting occurs, keep head low so that stomach content doesn't get into the lungs. |
| Most important symptoms/effects, acute and delayed | May cause drowsiness and dizziness. Headache. Nausea, vomiting. Rash. Skin irritation. May cause redness and pain. May cause an allergic skin reaction. Dermatitis. |
| Indication of immediate medical attention and special treatment needed | Provide general supportive measures and treat symptomatically. Keep victim under observation. Symptoms may be delayed. |
| General information | Ensure that medical personnel are aware of the material(s) involved, and take precautions to protect themselves. Wash contaminated clothing before reuse. |

5. Fire-fighting measures

| | |
|--|--|
| Suitable extinguishing media | Alcohol resistant foam. Water spray. Water fog. Dry chemical powder. Dry chemicals. Carbon dioxide (CO2). |
| Unsuitable extinguishing media | Do not use water jet as an extinguisher, as this will spread the fire. |
| Specific hazards arising from the chemical | Contents under pressure. Pressurized container may explode when exposed to heat or flame. During fire, gases hazardous to health may be formed. |
| Special protective equipment and precautions for firefighters | Firefighters must use standard protective equipment including flame retardant coat, helmet with face shield, gloves, rubber boots, and in enclosed spaces, SCBA. |
| Fire fighting equipment/instructions | In case of fire: Stop leak if safe to do so. Move containers from fire area if you can do so without risk. Cool containers exposed to heat with water spray and remove container, if no risk is involved. Containers should be cooled with water to prevent vapor pressure build up. For massive fire in cargo area, use unmanned hose holder or monitor nozzles, if possible. If not, withdraw and let fire burn out. |
| Specific methods | Use standard firefighting procedures and consider the hazards of other involved materials. Move containers from fire area if you can do so without risk. Cool containers exposed to flames with water until well after the fire is out. In the event of fire and/or explosion do not breathe fumes. |
| General fire hazards | Extremely flammable aerosol. Contents under pressure. Pressurized container may explode when exposed to heat or flame. |

6. Accidental release measures

| | |
|--|---|
| Personal precautions, protective equipment and emergency procedures | Keep unnecessary personnel away. Keep people away from and upwind of spill/leak. Keep out of low areas. Many gases are heavier than air and will spread along ground and collect in low or confined areas (sewers, basements, tanks). Wear appropriate protective equipment and clothing during clean-up. Avoid breathing gas. Do not touch damaged containers or spilled material unless wearing appropriate protective clothing. Ventilate closed spaces before entering them. Local authorities should be advised if significant spillages cannot be contained. Use personal protection recommended in Section 8 of the SDS. |
|--|---|

Methods and materials for containment and cleaning up

Refer to attached safety data sheets and/or instructions for use. Eliminate all ignition sources (no smoking, flares, sparks, or flames in immediate area). Keep combustibles (wood, paper, oil, etc.) away from spilled material. Stop leak if you can do so without risk. Move the cylinder to a safe and open area if the leak is irreparable. Use water spray to reduce vapors or divert vapor cloud drift. Isolate area until gas has dispersed. Dike far ahead of spill for later disposal. Scoop up used absorbent into drums or other appropriate container. Prevent entry into waterways, sewer, basements or confined areas. Following product recovery, flush area with water. For waste disposal, see section 13 of the SDS.

Environmental precautions

Avoid discharge into drains, water courses or onto the ground.

7. Handling and storage

Precautions for safe handling

Pressurized container: Do not pierce or burn, even after use. Do not use if spray button is missing or defective. Do not spray on a naked flame or any other incandescent material. Do not smoke while using or until sprayed surface is thoroughly dry. Do not cut, weld, solder, drill, grind, or expose containers to heat, flame, sparks, or other sources of ignition. Do not re-use empty containers. Avoid breathing gas. Avoid contact with eyes, skin, and clothing. Avoid prolonged exposure. Use only in well-ventilated areas. Wear appropriate personal protective equipment. Observe good industrial hygiene practices.

Conditions for safe storage, including any incompatibilities

Level 1 Aerosol.

Store locked up. Pressurized container. Protect from sunlight and do not expose to temperatures exceeding 50°C/122 °F. Do not puncture, incinerate or crush. Do not handle or store near an open flame, heat or other sources of ignition. Store in original tightly closed container. Store in a well-ventilated place. Keep out of the reach of children. Store away from incompatible materials (see Section 10 of the SDS).

8. Exposure controls/personal protection

Occupational exposure limits

U.S. - OSHA Components

| Components | Type | Value | Form |
|--|------|---------|----------|
| Distillates Petroleum, Hydrotreated Light (CAS 64742-47-8) | PEL | 5 mg/m3 | Oil mist |

US. OSHA Table Z-1 Limits for Air Contaminants (29 CFR 1910.1000) Components

| Components | Type | Value |
|-------------------------------|------|------------------------|
| Carbon Dioxide (CAS 124-38-9) | PEL | 9000 mg/m3 5000 ppm |

ACGIH Components

| Components | Type | Value | Form |
|--|------|---------|----------|
| Distillates Petroleum, Hydrotreated Light (CAS 64742-47-8) | TWA | 5 mg/m3 | Oil mist |

US. ACGIH Threshold Limit Values Components

| Components | Type | Value |
|-------------------------------|------|-----------|
| Carbon Dioxide (CAS 124-38-9) | STEL | 30000 ppm |
| | TWA | 5000 ppm |

US. NIOSH: Pocket Guide to Chemical Hazards Components

| Components | Type | Value |
|-------------------------------|------|--------------------------|
| Carbon Dioxide (CAS 124-38-9) | STEL | 54000 mg/m3 30000 ppm |
| | TWA | 9000 mg/m3 5000 ppm |

Biological limit values

No biological exposure limits noted for the ingredient(s).

Appropriate engineering controls

Good general ventilation (typically 10 air changes per hour) should be used. Ventilation rates should be matched to conditions. If applicable, use process enclosures, local exhaust ventilation, or other engineering controls to maintain airborne levels below recommended exposure limits. If exposure limits have not been established, maintain airborne levels to an acceptable level.

Individual protection measures, such as personal protective equipment

| | |
|---------------------------------------|---|
| Eye/face protection | Wear safety glasses with side shields (or goggles). |
| Skin protection | |
| Hand protection | Chemical resistant gloves are recommended. |
| Other | Avoid contact with the skin. Wear appropriate chemical resistant clothing. |
| Respiratory protection | When workers are facing concentrations above the exposure limit they must use appropriate certified respirators. |
| Thermal hazards | Not applicable. |
| General hygiene considerations | Always observe good personal hygiene measures, such as washing after handling the material and before eating, drinking, and/or smoking. Routinely wash work clothing and protective equipment to remove contaminants. |

9. Physical and chemical properties

| | |
|---|---|
| Appearance | Liquid. |
| Physical state | Gas. |
| Form | Aerosol. |
| Color | Amber. |
| Odor | Characteristic. |
| Odor threshold | Not available. |
| pH | Not applicable |
| Melting point/freezing point | < -58 °F (< -50 °C) |
| Initial boiling point and boiling range | 415.4 °F (213 °C) |
| Flash point | 174.2 °F (79.0 °C) Tag Closed Cup (dispensed liquid) |
| Evaporation rate | < 0.1 (BuAc = 1) |
| Flammability (solid, gas) | Flammable gas. |
| Upper/lower flammability or explosive limits | |
| Flammability limit - lower (%) | 0.6 % |
| Flammability limit - upper (%) | 7 % |
| Explosive limit - lower (%) | Not available. |
| Explosive limit - upper (%) | Not available. |
| Vapor pressure | < 0.05 mm Hg @ 20°C |
| Vapor density | > 1 (air = 1) |
| Relative density | 0.79 - 0.81 @ 20°C |
| Solubility(ies) | |
| Solubility (water) | Not soluble |
| Partition coefficient (n-octanol/water) | < 1 |
| Auto-ignition temperature | > 442.4 °F (> 228 °C) |
| Decomposition temperature | Not established |
| Viscosity | < 3.8 cSt @ 25°C |
| Other information | |
| Heat of combustion | Not established |
| Percent volatile | 95 - 96 % |
| VOC (Weight %) | 0.4 % per US State & Federal Consumer Product Regulations |

10. Stability and reactivity

| | |
|---------------------------|---|
| Reactivity | The product is stable and non-reactive under normal conditions of use, storage and transport. |
| Chemical stability | Material is stable under normal conditions. |

| | |
|---|--|
| Possibility of hazardous reactions | Hazardous polymerization does not occur. |
| Conditions to avoid | Avoid heat, sparks, open flames and other ignition sources. Avoid temperatures exceeding the flash point. Contact with incompatible materials. |
| Incompatible materials | Oxidizing agents. |
| Hazardous decomposition products | Carbon oxides. |

11. Toxicological information

Information on likely routes of exposure

| | |
|---------------------|--|
| Inhalation | Vapors have a narcotic effect and may cause headache, fatigue, dizziness and nausea. |
| Skin contact | Causes skin irritation. May cause an allergic skin reaction. |
| Eye contact | Direct contact with eyes may cause temporary irritation. |
| Ingestion | May be fatal if swallowed and enters airways. |

Symptoms related to the physical, chemical and toxicological characteristics
Symptoms may include stinging, tearing, redness, swelling, and blurred vision. Skin irritation. Exposure may cause temporary irritation, redness, or discomfort. Defatting of the skin. Rash. Vapors have a narcotic effect and may cause headache, fatigue, dizziness and nausea. Decrease in motor functions. Behavioral changes.

Information on toxicological effects

Acute toxicity Narcotic effects. May cause an allergic skin reaction.

| Components | Species | Test Results |
|---|--|---|
| Calcium Sulfonate (CAS 61789-86-4) | | |
| Acute | | |
| <i>Dermal</i> | | |
| LD50 | Rabbit | > 2000 mg/kg, 24 Hours |
| | Rat | > 2000 mg/kg, 24 Hours |
| <i>Inhalation</i> | | |
| LC50 | Rat | > 1.9 mg/l, 4 Hours |
| <i>Oral</i> | | |
| LD50 | Rat | 10000 - 20000 mg/kg |
| Distillates Petroleum Hydrotreated Med (CAS 64742-46-7) | | |
| Acute | | |
| <i>Dermal</i> | | |
| LD50 | Rabbit | > 2000 mg/kg, 24 Hours |
| <i>Inhalation</i> | | |
| LC50 | Rat | 7640 mg/m3, 4 Hours 1.72 mg/l, 4 Hours |
| Distillates Petroleum, Hydroteated Light (CAS 64742-47-8) | | |
| Acute | | |
| <i>Dermal</i> | | |
| LD50 | Rabbit | > 2000 mg/kg > 2000 mg/kg, 24 Hours |
| <i>Inhalation</i> | | |
| LC50 | Cat | > 6.4 mg/l, 6 Hours |
| | Rat | > 7.5 mg/l, 6 Hours > 4.3 mg/l, 4 Hours > 0.1 mg/l, 8 Hours |
| <i>Oral</i> | | |
| LD50 | Rat | > 5000 mg/kg |
| Skin corrosion/irritation | Causes skin irritation. | |
| Serious eye damage/eye irritation | Direct contact with eyes may cause temporary irritation. | |

Respiratory or skin sensitization

Respiratory sensitization Not a respiratory sensitizer.

Skin sensitization May cause an allergic skin reaction.

Germ cell mutagenicity No data available to indicate product or any components present at greater than 0.1% are mutagenic or genotoxic.

Carcinogenicity This product is not considered to be a carcinogen by IARC, ACGIH, NTP, or OSHA.

OSHA Specifically Regulated Substances (29 CFR 1910.1001-1050)

Not listed.

Reproductive toxicity This product is not expected to cause reproductive or developmental effects.

Specific target organ toxicity - single exposure Narcotic effects.

Specific target organ toxicity - repeated exposure Based on available data, the classification criteria are not met.

Aspiration hazard Not likely, due to the form of the product.

Chronic effects Prolonged inhalation may be harmful.

12. Ecological information

Ecotoxicity Harmful to aquatic life with long lasting effects.

| Components | Species | Test Results |
|--|---|--------------------|
| Distillates Petroleum, Hydrotreated Light (CAS 64742-47-8) | | |
| Aquatic | | |
| Fish | LC50 Rainbow trout, donaldson trout (Oncorhynchus mykiss) | 2.9 mg/l, 96 hours |

Persistence and degradability Not inherently biodegradable.

Bioaccumulative potential Not available.

Partition coefficient n-octanol / water (log Kow)

LPS® 1 (Aerosol) < 1

Mobility in soil No data available.

Other adverse effects None known.

13. Disposal considerations

Disposal instructions Consult authorities before disposal. Contents under pressure. Do not puncture, incinerate or crush. Dispose of contents/container in accordance with local/regional/national/international regulations.

Local disposal regulations Dispose in accordance with all applicable regulations.

Hazardous waste code D003: Waste Reactive material

Waste from residues / unused products Dispose of in accordance with local regulations. Empty containers or liners may retain some product residues. This material and its container must be disposed of in a safe manner (see: Disposal instructions).

Contaminated packaging Empty containers should be taken to an approved waste handling site for recycling or disposal. Since emptied containers may retain product residue, follow label warnings even after container is emptied. Do not re-use empty containers.

14. Transport information

DOT

UN number UN1950

UN proper shipping name Aerosols, flammable

Transport hazard class(es)

Class 2.1

Subsidiary risk -

Label(s) 2.1

Packing group Not applicable.

Environmental hazards

Marine pollutant No

Special precautions for user Read safety instructions, SDS and emergency procedures before handling.

Special provisions N82

Packaging exceptions 306

Packaging non bulk None
Packaging bulk None

IATA

UN number UN1950
UN proper shipping name Aerosols, flammable
Transport hazard class(es)
Class 2.1
Subsidiary risk -
Packing group Not applicable.
Environmental hazards No
ERG Code 10L
Special precautions for user Read safety instructions, SDS and emergency procedures before handling.
Other information
Passenger and cargo aircraft Allowed.
Cargo aircraft only Allowed.

IMDG

UN number UN1950
UN proper shipping name AEROSOLS, Flammable
Transport hazard class(es)
Class 2.1
Subsidiary risk -
Label(s) 2.1
Packing group Not applicable.
Environmental hazards
Marine pollutant No
EmS F-D, S-U
Special precautions for user Read safety instructions, SDS and emergency procedures before handling.

Transport in bulk according to Annex II of MARPOL 73/78 and the IBC Code This substance/mixture is not intended to be transported in bulk.

DOT**IATA; IMDG****15. Regulatory information**

US federal regulations This product is a "Hazardous Chemical" as defined by the OSHA Hazard Communication Standard, 29 CFR 1910.1200.
All components are on the U.S. EPA TSCA Inventory List.

TSCA Section 12(b) Export Notification (40 CFR 707, Subpt. D)

Not regulated.

CERCLA Hazardous Substance List (40 CFR 302.4)

Not listed.

SARA 304 Emergency release notification

Not regulated.

OSHA Specifically Regulated Substances (29 CFR 1910.1001-1050)

Not listed.

Superfund Amendments and Reauthorization Act of 1986 (SARA)

Hazard categories
 Immediate Hazard - Yes
 Delayed Hazard - No
 Fire Hazard - Yes
 Pressure Hazard - Yes
 Reactivity Hazard - No

SARA 302 Extremely hazardous substance

Not listed.

SARA 311/312 Hazardous chemical Yes

SARA 313 (TRI reporting)

Not regulated.

Other federal regulations**Clean Air Act (CAA) Section 112 Hazardous Air Pollutants (HAPs) List**

Not regulated.

Clean Air Act (CAA) Section 112(r) Accidental Release Prevention (40 CFR 68.130)

Not regulated.

Safe Drinking Water Act (SDWA) Not regulated.

US state regulations**US. California Controlled Substances. CA Department of Justice (California Health and Safety Code Section 11100)**

Not listed.

US. Massachusetts RTK - Substance List

Carbon Dioxide (CAS 124-38-9)

US. New Jersey Worker and Community Right-to-Know Act

Carbon Dioxide (CAS 124-38-9)

US. Pennsylvania Worker and Community Right-to-Know Law

Carbon Dioxide (CAS 124-38-9)

US. Rhode Island RTK

Not regulated.

US. California Proposition 65

California Safe Drinking Water and Toxic Enforcement Act of 1986 (Proposition 65): This material is not known to contain any chemicals currently listed as carcinogens or reproductive toxins.

International Inventories

| Country(s) or region | Inventory name | On inventory (yes/no)* |
|----------------------|--|------------------------|
| Australia | Australian Inventory of Chemical Substances (AICS) | Yes |
| Canada | Domestic Substances List (DSL) | Yes |
| Canada | Non-Domestic Substances List (NDSL) | No |
| China | Inventory of Existing Chemical Substances in China (IECSC) | No |
| Europe | European Inventory of Existing Commercial Chemical Substances (EINECS) | Yes |
| Europe | European List of Notified Chemical Substances (ELINCS) | No |
| Japan | Inventory of Existing and New Chemical Substances (ENCS) | No |
| Korea | Existing Chemicals List (ECL) | Yes |
| New Zealand | New Zealand Inventory | No |
| Philippines | Philippine Inventory of Chemicals and Chemical Substances (PICCS) | Yes |

| Country(s) or region | Inventory name | On inventory (yes/no)* |
|-----------------------------|---|------------------------|
| United States & Puerto Rico | Toxic Substances Control Act (TSCA) Inventory | Yes |

*A "Yes" indicates that all components of this product comply with the inventory requirements administered by the governing country(s)
A "No" indicates that one or more components of the product are not listed or exempt from listing on the inventory administered by the governing country(s).

16. Other information, including date of preparation or last revision

| | |
|-------------------|---|
| Issue date | 10-01-2014 |
| Version # | 01 |
| Disclaimer | LPS Laboratories cannot anticipate all conditions under which this information and its product, or the products of other manufacturers in combination with its product, may be used. It is the user's responsibility to ensure safe conditions for handling, storage and disposal of the product, and to assume liability for loss, injury, damage or expense due to improper use. The information provided in this Safety Data Sheet is correct to the best of our knowledge, information and belief at the date of its publication. The information given is designed only as a guidance for safe handling, use, processing, storage, transportation, disposal and release and is not to be considered a warranty or quality specification. The information relates only to the specific material designated and may not be valid for such material used in combination with any other materials or in any process, unless specified in the text. |



SAFETY DATA SHEET

1. Identification

| | |
|---|---|
| Product identifier | LPS® 2 (Aerosol) |
| Other means of identification | |
| Part Number | 00216 |
| Recommended use | An industrial lubricant designed to displace moisture from equipment, provide heavy-duty lubrication and rust prevention. |
| Recommended restrictions | None known. |
| Manufacturer/Importer/Supplier/Distributor information | |
| Manufacturer | |
| Manufacturer | |
| Company name | LPS Laboratories, a division of Illinois Tool Works, Inc. |
| Address | 4647 Hugh Howell Rd. Tucker, GA 30084 (U.S.A.) |
| Country | (U.S.A.) |
| In Case of Emergency | Tel: +1 770-243-8800 1-800-424-9300 (inside U.S.) +001 703-527-3887 (outside U.S.) |
| Website | www.lpslabs.com |
| E-mail | sds@lpslabs.com |

2. Hazard(s) identification

| | | |
|------------------------------|---|-----------------------------|
| Physical hazards | Flammable aerosols | Category 1 |
| | Gases under pressure | Compressed gas |
| Health hazards | Skin corrosion/irritation | Category 2 |
| | Serious eye damage/eye irritation | Category 2A |
| | Specific target organ toxicity, single exposure | Category 3 narcotic effects |
| Environmental hazards | Not classified. | |
| OSHA defined hazards | Not classified. | |
| Label elements | | |



| | |
|--|--|
| Signal word | Danger |
| Hazard statement | Extremely flammable aerosol. Contains gas under pressure; may explode if heated. Causes skin irritation. Causes serious eye irritation. May cause drowsiness or dizziness. |
| Precautionary statement | |
| Prevention | Keep away from heat/sparks/open flames/hot surfaces. - No smoking. Do not spray on an open flame or other ignition source. Pressurized container: Do not pierce or burn, even after use. Avoid breathing gas. Wash thoroughly after handling. Use only outdoors or in a well-ventilated area. Wear protective gloves. Wear eye/face protection. |
| Response | If on skin: Wash with plenty of water. If inhaled: Remove person to fresh air and keep comfortable for breathing. If in eyes: Rinse cautiously with water for several minutes. Remove contact lenses, if present and easy to do. Continue rinsing. Call a poison center/doctor if you feel unwell. Specific treatment (see this label). If skin irritation occurs: Get medical advice/attention. If eye irritation persists: Get medical advice/attention. Take off contaminated clothing and wash before reuse. |
| Storage | Store in a well-ventilated place. Keep container tightly closed. Store locked up. Protect from sunlight. Do not expose to temperatures exceeding 50°C/122°F. |
| Disposal | Dispose of contents/container in accordance with local/regional/national/international regulations. |
| Hazard(s) not otherwise classified (HNOC) | None known. |

Supplemental information None.

3. Composition/information on ingredients

Mixtures

| Chemical name | Common name and synonyms | CAS number | % |
|---|--------------------------|------------|---------|
| Distillates Petroleum, Hydrotreated Light | | 64742-47-8 | 70 - 80 |
| Petroleum Oil | | 64742-52-5 | 10 - 20 |
| Carbon Dioxide | | 124-38-9 | 1 - 5 |

4. First-aid measures

| | |
|---|---|
| Inhalation | Remove victim to fresh air and keep at rest in a position comfortable for breathing. For breathing difficulties, oxygen may be necessary. Call a physician if symptoms develop or persist. |
| Skin contact | Wash off with soap and water. Get medical attention if irritation develops and persists. |
| Eye contact | Immediately flush eyes with plenty of water for at least 15 minutes. Remove contact lenses, if present and easy to do. Continue rinsing. Get medical attention if irritation develops and persists. |
| Ingestion | Call a physician or poison control center immediately. Only induce vomiting at the instruction of medical personnel. Never give anything by mouth to an unconscious person. If vomiting occurs, keep head low so that stomach content doesn't get into the lungs. |
| Most important symptoms/effects, acute and delayed | Dermatitis. Rash. Symptoms of overexposure may be headache, dizziness, tiredness, nausea and vomiting. Skin irritation. May cause redness and pain. |
| Indication of immediate medical attention and special treatment needed | Provide general supportive measures and treat symptomatically. |
| General information | Ensure that medical personnel are aware of the material(s) involved, and take precautions to protect themselves. Call a POISON CENTER or doctor/physician if you feel unwell. |

5. Fire-fighting measures

| | |
|--|--|
| Suitable extinguishing media | Powder. Alcohol resistant foam. Water. Water spray. Dry chemicals. Carbon dioxide (CO2). |
| Unsuitable extinguishing media | Do not use water jet as an extinguisher, as this will spread the fire. |
| Specific hazards arising from the chemical | Contents under pressure. Pressurized container may explode when exposed to heat or flame. |
| Special protective equipment and precautions for firefighters | Firefighters must use standard protective equipment including flame retardant coat, helmet with face shield, gloves, rubber boots, and in enclosed spaces, SCBA. |
| Fire fighting equipment/instructions | In case of fire: Stop leak if safe to do so. Move containers from fire area if you can do so without risk. Cool containers exposed to heat with water spray and remove container, if no risk is involved. Containers should be cooled with water to prevent vapor pressure build up. For massive fire in cargo area, use unmanned hose holder or monitor nozzles, if possible. If not, withdraw and let fire burn out. |
| Specific methods | Use standard firefighting procedures and consider the hazards of other involved materials. Move containers from fire area if you can do so without risk. Cool containers exposed to flames with water until well after the fire is out. In the event of fire and/or explosion do not breathe fumes. |
| General fire hazards | Extremely flammable aerosol. |

6. Accidental release measures

| | |
|--|--|
| Personal precautions, protective equipment and emergency procedures | Keep unnecessary personnel away. Keep people away from and upwind of spill/leak. Keep out of low areas. Wear appropriate protective equipment and clothing during clean-up. Do not touch damaged containers or spilled material unless wearing appropriate protective clothing. Ventilate closed spaces before entering them. Local authorities should be advised if significant spillages cannot be contained. Use personal protection recommended in Section 8 of the SDS. |
| Methods and materials for containment and cleaning up | Refer to attached safety data sheets and/or instructions for use. Eliminate all ignition sources (no smoking, flares, sparks, or flames in immediate area). Keep combustibles (wood, paper, oil, etc.) away from spilled material. Stop leak if you can do so without risk. Move the cylinder to a safe and open area if the leak is irreparable. Isolate area until gas has dispersed. Use water spray to reduce vapors or divert vapor cloud drift. Scoop up used absorbent into drums or other appropriate container. Prevent entry into waterways, sewer, basements or confined areas. Following product recovery, flush area with water. For waste disposal, see section 13 of the SDS. |
| Environmental precautions | Avoid discharge into drains, water courses or onto the ground. |

Material name: LPS® 2 (Aerosol)
729 Version #: 01 Issue date: 09-22-2014

SDS US
2 / 9

7. Handling and storage

Precautions for safe handling

Pressurized container: Do not pierce or burn, even after use. Do not use if spray button is missing or defective. Do not spray on a naked flame or any other incandescent material. Do not smoke while using or until sprayed surface is thoroughly dry. Do not cut, weld, solder, drill, grind, or expose containers to heat, flame, sparks, or other sources of ignition. All equipment used when handling the product must be grounded. Do not re-use empty containers. Avoid prolonged or repeated contact with skin. Avoid prolonged exposure. Use only in well-ventilated areas. Wear appropriate personal protective equipment. Wash hands thoroughly after handling. Observe good industrial hygiene practices.

Conditions for safe storage, including any incompatibilities

Level 3 Aerosol.

Store locked up. Pressurized container. Protect from sunlight and do not expose to temperatures exceeding 50°C/122 °F. Do not puncture, incinerate or crush. Do not handle or store near an open flame, heat or other sources of ignition. This material can accumulate static charge which may cause spark and become an ignition source. Prevent electrostatic charge build-up by using common bonding and grounding techniques. Store in original tightly closed container. Store in a well-ventilated place. Store away from incompatible materials (see Section 10 of the SDS). Keep out of the reach of children.

8. Exposure controls/personal protection

Occupational exposure limits

U.S. - OSHA Components

| Components | Type | Value | Form |
|--|------|---------|----------|
| Distillates Petroleum, Hydrotreated Light (CAS 64742-47-8) | PEL | 5 mg/m3 | Oil mist |
| Petroleum Oil (CAS 64742-52-5) | PEL | 5 mg/m3 | Oil mist |

US. OSHA Table Z-1 Limits for Air Contaminants (29 CFR 1910.1000)

| Components | Type | Value |
|-------------------------------|------|------------------------|
| Carbon Dioxide (CAS 124-38-9) | PEL | 9000 mg/m3 5000 ppm |

ACGIH

| Components | Type | Value | Form |
|--|------|---------|----------|
| Distillates Petroleum, Hydrotreated Light (CAS 64742-47-8) | TWA | 5 mg/m3 | Oil mist |
| Petroleum Oil (CAS 64742-52-5) | TWA | 5 mg/m3 | Oil mist |

US. ACGIH Threshold Limit Values

| Components | Type | Value |
|-------------------------------|------|-----------|
| Carbon Dioxide (CAS 124-38-9) | STEL | 30000 ppm |
| | TWA | 5000 ppm |

US. NIOSH: Pocket Guide to Chemical Hazards

| Components | Type | Value |
|-------------------------------|------|--------------------------|
| Carbon Dioxide (CAS 124-38-9) | STEL | 54000 mg/m3 30000 ppm |
| | TWA | 9000 mg/m3 5000 ppm |

Biological limit values

No biological exposure limits noted for the ingredient(s).

Appropriate engineering controls

Good general ventilation (typically 10 air changes per hour) should be used. Ventilation rates should be matched to conditions. If applicable, use process enclosures, local exhaust ventilation, or other engineering controls to maintain airborne levels below recommended exposure limits. If exposure limits have not been established, maintain airborne levels to an acceptable level. Eye wash facilities and emergency shower must be available when handling this product.

Individual protection measures, such as personal protective equipment

Eye/face protection

Wear safety glasses with side shields (or goggles).

| | |
|---------------------------------------|---|
| Skin protection | |
| Hand protection | Chemical resistant gloves are recommended. |
| Other | Wear suitable protective clothing. |
| Respiratory protection | In case of insufficient ventilation, wear suitable respiratory equipment. |
| Thermal hazards | Not applicable. |
| General hygiene considerations | When using, do not eat, drink or smoke. Always observe good personal hygiene measures, such as washing after handling the material and before eating, drinking, and/or smoking. Routinely wash work clothing and protective equipment to remove contaminants. |

9. Physical and chemical properties

| | |
|---|--|
| Appearance | Liquid. |
| Physical state | Gas. |
| Form | Aerosol. |
| Color | Brown |
| Odor | Slight petroleum odor, Cherry |
| Odor threshold | Not established |
| pH | Not applicable |
| Melting point/freezing point | < -58 °F (< -50 °C) |
| Initial boiling point and boiling range | 383 °F (195 °C) @ 101 kPa |
| Flash point | 174.2 °F (79.0 °C) Tag Closed Cup (dispensed liquid) |
| Evaporation rate | < 0.1 BuAc |
| Flammability (solid, gas) | Flammable gas. |
| Upper/lower flammability or explosive limits | |
| Flammability limit - lower (%) | 0.6 % |
| Flammability limit - upper (%) | 7 % |
| Explosive limit - lower (%) | Not available. |
| Explosive limit - upper (%) | Not available. |
| Vapor pressure | < 0.05 mm Hg @ 20°C (dispensed liquid) |
| Vapor density | 4.7 (air = 1) |
| Relative density | Not available. |
| Solubility(ies) | |
| Solubility (water) | < 3 % |
| Partition coefficient (n-octanol/water) | < 1 |
| Auto-ignition temperature | > 442.4 °F (> 228 °C) |
| Decomposition temperature | Not established |
| Viscosity | < 7 cSt |
| Viscosity temperature | 77 °F (25 °C) |
| Other information | |
| Heat of combustion | > 30 kJ/g |
| Percent volatile | 92 - 95 % |
| Specific gravity | 0.82 - 0.86 @ 20°C |

10. Stability and reactivity

| | |
|---|--|
| Reactivity | The product is stable and non-reactive under normal conditions of use, storage and transport. |
| Chemical stability | Material is stable under normal conditions. |
| Possibility of hazardous reactions | Hazardous polymerization does not occur. |
| Conditions to avoid | Avoid heat, sparks, open flames and other ignition sources. Avoid temperatures exceeding the flash point. Contact with incompatible materials. |

Incompatible materials Strong oxidizing agents.
Hazardous decomposition products Carbon oxides.

11. Toxicological information

Information on likely routes of exposure

Inhalation Vapors have a narcotic effect and may cause headache, fatigue, dizziness and nausea.
Skin contact Causes skin irritation.
Eye contact Causes serious eye irritation.
Ingestion May cause discomfort if swallowed.

Symptoms related to the physical, chemical and toxicological characteristics Irritating to eyes, respiratory system and skin. Symptoms may include stinging, tearing, redness, swelling, and blurred vision. Exposure may cause temporary irritation, redness, or discomfort. Vapors have a narcotic effect and may cause headache, fatigue, dizziness and nausea.

Information on toxicological effects

Acute toxicity Narcotic effects.

| Components | Species | Test Results |
|---|--|---|
| Distillates Petroleum, Hydrotreated Light (CAS 64742-47-8) | | |
| Acute | | |
| <i>Dermal</i> | | |
| LD50 | Rabbit | > 2000 mg/kg > 2000 mg/kg, 24 Hours |
| <i>Inhalation</i> | | |
| LC50 | Cat | > 6.4 mg/l, 6 Hours |
| | Rat | > 7.5 mg/l, 6 Hours > 4.3 mg/l, 4 Hours > 0.1 mg/l, 8 Hours |
| <i>Oral</i> | | |
| LD50 | Rat | > 5000 mg/kg |
| Petroleum Oil (CAS 64742-52-5) | | |
| Acute | | |
| <i>Dermal</i> | | |
| LD50 | Rabbit | > 2000 mg/kg > 2000 mg/kg, 24 Hours |
| <i>Inhalation</i> | | |
| LC50 | Rat | 2.18 mg/l, 4 Hours |
| <i>Oral</i> | | |
| LD50 | Rat | 5000 mg/kg |
| Skin corrosion/irritation | Causes skin irritation. | |
| Serious eye damage/eye irritation | Causes serious eye irritation. | |
| Respiratory or skin sensitization | | |
| Respiratory sensitization | Not a respiratory sensitizer. | |
| Skin sensitization | This product is not expected to cause skin sensitization. | |
| Germ cell mutagenicity | No data available to indicate product or any components present at greater than 0.1% are mutagenic or genotoxic. | |
| Carcinogenicity | This product is not considered to be a carcinogen by IARC, ACGIH, NTP, or OSHA. | |
| OSHA Specifically Regulated Substances (29 CFR 1910.1001-1050) | | |
| Not listed. | | |
| Reproductive toxicity | This product is not expected to cause reproductive or developmental effects. | |
| Specific target organ toxicity - single exposure | Narcotic effects. | |

| | |
|---|---|
| Specific target organ toxicity - repeated exposure | Based on available data, the classification criteria are not met. |
| Aspiration hazard | Not likely, due to the form of the product. |
| Chronic effects | Prolonged inhalation may be harmful. |

12. Ecological information

Ecotoxicity The product is not classified as environmentally hazardous. However, this does not exclude the possibility that large or frequent spills can have a harmful or damaging effect on the environment.

| Components | Species | Test Results |
|--|---|--------------------|
| Distillates Petroleum, Hydrotreated Light (CAS 64742-47-8) | | |
| Aquatic | | |
| Fish | LC50 Rainbow trout, donaldson trout (Oncorhynchus mykiss) | 2.9 mg/l, 96 hours |

Persistence and degradability Not inherently biodegradable.

Bioaccumulative potential Not available.

Partition coefficient n-octanol / water (log Kow)
LPS@ 2 (Aerosol) < 1

Mobility in soil No data available.

Other adverse effects None known.

13. Disposal considerations

Disposal instructions Consult authorities before disposal. Contents under pressure. Do not puncture, incinerate or crush. Dispose of contents/container in accordance with local/regional/national/international regulations.

Local disposal regulations Dispose in accordance with all applicable regulations.

Hazardous waste code D003: Waste Reactive material

Waste from residues / unused products Dispose of in accordance with local regulations. Empty containers or liners may retain some product residues. This material and its container must be disposed of in a safe manner (see: Disposal instructions).

Contaminated packaging Empty containers should be taken to an approved waste handling site for recycling or disposal. Since emptied containers may retain product residue, follow label warnings even after container is emptied. Do not re-use empty containers.

14. Transport information

DOT

| | |
|-------------------------------------|---|
| UN number | UN1950 |
| UN proper shipping name | Aerosols, flammable |
| Transport hazard class(es) | |
| Class | 2.1 |
| Subsidiary risk | - |
| Label(s) | 2.1 |
| Packing group | Not applicable. |
| Environmental hazards | |
| Marine pollutant | No |
| Special precautions for user | Read safety instructions, SDS and emergency procedures before handling. Read safety instructions, SDS and emergency procedures before handling. |
| Packaging exceptions | 306 |
| Packaging non bulk | None |
| Packaging bulk | None |

IATA

| | |
|-----------------------------------|---------------------|
| UN number | UN1950 |
| UN proper shipping name | Aerosols, flammable |
| Transport hazard class(es) | |
| Class | 2.1 |
| Subsidiary risk | - |
| Label(s) | 2.1 |
| Packing group | Not applicable. |
| Environmental hazards | No. |
| ERG Code | 10L |

Special precautions for user Read safety instructions, SDS and emergency procedures before handling. Read safety instructions, SDS and emergency procedures before handling.

Other information

Passenger and cargo aircraft Allowed.

Cargo aircraft only Allowed.

IMDG

UN number UN1950

UN proper shipping name AEROSOLS, flammable

Transport hazard class(es)

Class 2.1

Subsidiary risk -

Label(s) 2.1

Packing group Not applicable.

Environmental hazards

Marine pollutant No

EmS Not available.

Special precautions for user Read safety instructions, SDS and emergency procedures before handling. Read safety instructions, SDS and emergency procedures before handling.

Transport in bulk according to Annex II of MARPOL 73/78 and the IBC Code Not applicable.

DOT



IATA; IMDG



15. Regulatory information

US federal regulations This product is a "Hazardous Chemical" as defined by the OSHA Hazard Communication Standard, 29 CFR 1910.1200.

TSCA Section 12(b) Export Notification (40 CFR 707, Subpt. D)

Not regulated.

CERCLA Hazardous Substance List (40 CFR 302.4)

Not listed.

SARA 304 Emergency release notification

Not regulated.

OSHA Specifically Regulated Substances (29 CFR 1910.1001-1050)

Not listed.

Superfund Amendments and Reauthorization Act of 1986 (SARA)

Hazard categories Immediate Hazard - Yes
 Delayed Hazard - No
 Fire Hazard - Yes
 Pressure Hazard - Yes
 Reactivity Hazard - No

SARA 302 Extremely hazardous substance

Not listed.

SARA 311/312 Hazardous chemical Yes

SARA 313 (TRI reporting)

Not regulated.

Other federal regulations**Clean Air Act (CAA) Section 112 Hazardous Air Pollutants (HAPs) List**

Not regulated.

Clean Air Act (CAA) Section 112(r) Accidental Release Prevention (40 CFR 68.130)

Not regulated.

Safe Drinking Water Act (SDWA) Not regulated.

US state regulations**US. California Controlled Substances. CA Department of Justice (California Health and Safety Code Section 11100)**

Not listed.

US. Massachusetts RTK - Substance List

Carbon Dioxide (CAS 124-38-9)

US. New Jersey Worker and Community Right-to-Know Act

Carbon Dioxide (CAS 124-38-9)

US. Pennsylvania Worker and Community Right-to-Know Law

Carbon Dioxide (CAS 124-38-9)

US. Rhode Island RTK

Not regulated.

US. California Proposition 65

California Safe Drinking Water and Toxic Enforcement Act of 1986 (Proposition 65): This material is not known to contain any chemicals currently listed as carcinogens or reproductive toxins.

International Inventories

| Country(s) or region | Inventory name | On inventory (yes/no)* |
|-----------------------------|--|------------------------|
| Australia | Australian Inventory of Chemical Substances (AICS) | Yes |
| Canada | Domestic Substances List (DSL) | Yes |
| Canada | Non-Domestic Substances List (NDSL) | No |
| China | Inventory of Existing Chemical Substances in China (IECSC) | No |
| Europe | European Inventory of Existing Commercial Chemical Substances (EINECS) | Yes |
| Europe | European List of Notified Chemical Substances (ELINCS) | No |
| Japan | Inventory of Existing and New Chemical Substances (ENCS) | No |
| Korea | Existing Chemicals List (ECL) | Yes |
| New Zealand | New Zealand Inventory | No |
| Philippines | Philippine Inventory of Chemicals and Chemical Substances (PICCS) | Yes |
| United States & Puerto Rico | Toxic Substances Control Act (TSCA) Inventory | Yes |

*A "Yes" indicates that all components of this product comply with the inventory requirements administered by the governing country(s)

A "No" indicates that one or more components of the product are not listed or exempt from listing on the inventory administered by the governing country(s).

16. Other information, including date of preparation or last revision

Issue date 09-22-2014

Version # 01

Disclaimer

The information provided in this Safety Data Sheet is correct to the best of our knowledge, information and belief at the date of its publication. The information given is designed only as a guidance for safe handling, use, processing, storage, transportation, disposal and release and is not to be considered a warranty or quality specification. The information relates only to the specific material designated and may not be valid for such material used in combination with any other materials or in any process, unless specified in the text.

Revision Information

Product and Company Identification: Product Uses
Composition / Information on Ingredients: Ingredients
Physical & Chemical Properties: Multiple Properties
Ecological Information: Ecotox Property Data
Transport Information: Proper Shipping Name/Packing Group
Regulatory Information: United States
HazReg Data: North America
GHS: Classification



SAFETY DATA SHEET

1. Identification

| | |
|---|--|
| Product identifier | LPS® All Purpose Anti-Seize |
| Other means of identification | |
| Part Number | 04108, 04110, 04105 |
| Recommended use | An all-purpose, anti-seize lubricant designed to prevent seizure and galling and resist settling and hardening of welding. |
| Recommended restrictions | None known. |
| Manufacturer/Importer/Supplier/Distributor information | |
| Manufacturer | |
| Manufacturer | |
| Company name | LPS Laboratories, a division of Illinois Tool Works, Inc. |
| Address | 4647 Hugh Howell Rd. Tucker, GA 30084 (U.S.A.) |
| Country | (U.S.A.) |
| In Case of Emergency | Tel: +1 770-243-8800 1-800-424-9300 (inside U.S.) +001 703-527-3887 (outside U.S.) |
| Website | www.lpslabs.com |
| E-mail | sds@lpslabs.com |

2. Hazard(s) identification

| | |
|--|--|
| Physical hazards | Not classified. |
| Health hazards | Not classified. |
| Environmental hazards | Not classified. |
| OSHA defined hazards | Not classified. |
| Label elements | |
| Hazard symbol | None. |
| Signal word | None. |
| Hazard statement | The mixture does not meet the criteria for classification. |
| Precautionary statement | |
| Prevention | Observe good industrial hygiene practices. |
| Response | Wash hands after handling. |
| Storage | Store away from incompatible materials. |
| Disposal | Dispose of waste and residues in accordance with local authority requirements. |
| Hazard(s) not otherwise classified (HNOC) | None known. |
| Supplemental information | None. |

3. Composition/information on ingredients

Mixtures

| Chemical name | Common name and synonyms | CAS number | % |
|-------------------------|--------------------------|------------|-------|
| Molybdenum (IV) sulfide | | 1317-33-5 | 1 - 5 |
| Zinc oxide | | 1314-13-2 | 1 - 2 |

4. First-aid measures

| | |
|---------------------|--|
| Inhalation | Move to fresh air. Call a physician if symptoms develop or persist. |
| Skin contact | Wash off with soap and water. Get medical attention if irritation develops and persists. |
| Eye contact | Rinse with water. Get medical attention if irritation develops and persists. |

| | |
|---|---|
| Ingestion | Rinse mouth. Get medical attention if symptoms occur. |
| Most important symptoms/effects, acute and delayed | Direct contact with eyes may cause temporary irritation. Exposed individuals may experience eye tearing, redness, and discomfort. |
| Indication of immediate medical attention and special treatment needed | Treat symptomatically. |
| General information | Ensure that medical personnel are aware of the material(s) involved, and take precautions to protect themselves. |

5. Fire-fighting measures

| | |
|--|---|
| Suitable extinguishing media | Water fog. Foam. Dry chemical powder. Carbon dioxide (CO ₂). |
| Unsuitable extinguishing media | Do not use a solid water stream as it may scatter and spread fire. |
| Specific hazards arising from the chemical | During fire, gases hazardous to health may be formed. |
| Special protective equipment and precautions for firefighters | Self-contained breathing apparatus and full protective clothing must be worn in case of fire. |
| Fire fighting equipment/instructions | Use water spray to cool unopened containers. |
| Specific methods | Use standard firefighting procedures and consider the hazards of other involved materials. |
| General fire hazards | No unusual fire or explosion hazards noted. |

6. Accidental release measures

| | |
|--|---|
| Personal precautions, protective equipment and emergency procedures | Keep unnecessary personnel away. Do not touch damaged containers or spilled material unless wearing appropriate protective clothing. Use personal protection recommended in Section 8 of the SDS. |
| Methods and materials for containment and cleaning up | Stop the flow of material, if this is without risk. Prevent entry into waterways, sewer, basements or confined areas. Following product recovery, flush area with water. For waste disposal, see section 13 of the SDS. |
| Environmental precautions | Avoid discharge into drains, water courses or onto the ground. |

7. Handling and storage

| | |
|---|---|
| Precautions for safe handling | Avoid prolonged exposure. Observe good industrial hygiene practices. |
| Conditions for safe storage, including any incompatibilities | Store in original tightly closed container. Store away from incompatible materials (see Section 10 of the SDS). |

8. Exposure controls/personal protection

Occupational exposure limits

US. OSHA Table Z-1 Limits for Air Contaminants (29 CFR 1910.1000)

| Components | Type | Value | Form |
|----------------------------|------|----------------------|----------------------|
| Zinc Oxide (CAS 1314-13-2) | PEL | 5 mg/m ³ | Fume. |
| | | 5 mg/m ³ | Respirable fraction. |
| | | 15 mg/m ³ | Total dust. |

US. ACGIH Threshold Limit Values

| Components | Type | Value | Form |
|----------------------------|------|----------------------|----------------------|
| Zinc Oxide (CAS 1314-13-2) | STEL | 10 mg/m ³ | Respirable fraction. |
| | TWA | 2 mg/m ³ | Respirable fraction. |

US. NIOSH: Pocket Guide to Chemical Hazards

| Components | Type | Value | Form |
|----------------------------|---------|----------------------|-------|
| Zinc Oxide (CAS 1314-13-2) | Ceiling | 15 mg/m ³ | Dust. |
| | STEL | 10 mg/m ³ | Fume. |
| | TWA | 5 mg/m ³ | Dust. |
| | | 5 mg/m ³ | Fume. |

Biological limit values No biological exposure limits noted for the ingredient(s).

| | |
|--|---|
| Appropriate engineering controls | Good general ventilation (typically 10 air changes per hour) should be used. Ventilation rates should be matched to conditions. If applicable, use process enclosures, local exhaust ventilation, or other engineering controls to maintain airborne levels below recommended exposure limits. If exposure limits have not been established, maintain airborne levels to an acceptable level. |
| Individual protection measures, such as personal protective equipment | |
| Eye/face protection | Wear safety glasses with side shields (or goggles). |
| Skin protection | |
| Hand protection | Wear appropriate chemical resistant gloves. |
| Other | Wear suitable protective clothing. |
| Respiratory protection | In case of insufficient ventilation, wear suitable respiratory equipment. |
| Thermal hazards | Wear appropriate thermal protective clothing, when necessary. |
| General hygiene considerations | Always observe good personal hygiene measures, such as washing after handling the material and before eating, drinking, and/or smoking. Routinely wash work clothing and protective equipment to remove contaminants. |

9. Physical and chemical properties

| | |
|---|-------------------------|
| Appearance | Paste. |
| Physical state | Solid. |
| Form | Solid. |
| Color | Dark grey. |
| Odor | Hydrocarbon-like. |
| Odor threshold | Not available. |
| pH | Not available. |
| Melting point/freezing point | 500 °F (260 °C) |
| Initial boiling point and boiling range | > 600.8 °F (> 316 °C) |
| Flash point | > 429.8 °F (> 221.0 °C) |
| Evaporation rate | Not available. |
| Flammability (solid, gas) | Not available. |
| Upper/lower flammability or explosive limits | |
| Flammability limit - lower (%) | Not available. |
| Flammability limit - upper (%) | Not available. |
| Explosive limit - lower (%) | Not available. |
| Explosive limit - upper (%) | Not available. |
| Vapor pressure | Not available. |
| Vapor density | Not available. |
| Relative density | Not available. |
| Solubility(ies) | |
| Solubility (water) | Insoluble |
| Partition coefficient (n-octanol/water) | Not available. |
| Auto-ignition temperature | Not available. |
| Decomposition temperature | Not available. |
| Viscosity | Not available. |
| Other information | |
| Specific gravity | 1.19 |
| VOC (Weight %) | Negligible |

10. Stability and reactivity

| | |
|---------------------------|---|
| Reactivity | The product is stable and non-reactive under normal conditions of use, storage and transport. |
| Chemical stability | Material is stable under normal conditions. |

| | |
|---|--|
| Possibility of hazardous reactions | Hazardous polymerization does not occur. |
| Conditions to avoid | Heat, flames and sparks. |
| Incompatible materials | Strong oxidizing agents. |
| Hazardous decomposition products | No hazardous decomposition products are known. |

11. Toxicological information

Information on likely routes of exposure

| | |
|---------------------|---|
| Inhalation | No adverse effects due to inhalation are expected. |
| Skin contact | Frequent or prolonged contact may defat and dry the skin, leading to discomfort and dermatitis. |
| Eye contact | Direct contact with eyes may cause temporary irritation. |
| Ingestion | May cause discomfort if swallowed. However, ingestion is not likely to be a primary route of occupational exposure. |

Symptoms related to the physical, chemical and toxicological characteristics
 Direct contact with eyes may cause temporary irritation. Exposure may cause temporary irritation, redness, or discomfort.

Information on toxicological effects

Acute toxicity Expected to be a low hazard for usual industrial or commercial handling by trained personnel.

| Components | Species | Test Results |
|----------------------------|---------|---------------------|
| Zinc oxide (CAS 1314-13-2) | | |
| Acute | | |
| <i>Inhalation</i> | | |
| LC50 | Mouse | > 5.7 mg/l, 4 Hours |
| | Rat | > 5700 mg/m3 |
| <i>Oral</i> | | |
| LD50 | Mouse | 2000 - 5000 mg/kg |
| | Rat | > 5 g/kg |
| <i>Other</i> | | |
| LD50 | Rat | 240 mg/kg |

Skin corrosion/irritation Prolonged skin contact may cause temporary irritation.

Serious eye damage/eye irritation Direct contact with eyes may cause temporary irritation.

Respiratory or skin sensitization

| | |
|----------------------------------|---|
| Respiratory sensitization | Not a respiratory sensitizer. |
| Skin sensitization | This product is not expected to cause skin sensitization. |

Germ cell mutagenicity No data available to indicate product or any components present at greater than 0.1% are mutagenic or genotoxic.

Carcinogenicity This product is not considered to be a carcinogen by IARC, ACGIH, NTP, or OSHA.

OSHA Specifically Regulated Substances (29 CFR 1910.1001-1050)

Not listed.

Reproductive toxicity This product is not expected to cause reproductive or developmental effects.

Specific target organ toxicity - single exposure Not classified.

Specific target organ toxicity - repeated exposure Not classified.

Aspiration hazard Not likely, due to the form of the product.

Chronic effects None known.

Further information This product has no known adverse effect on human health.

12. Ecological information

Ecotoxicity The product is not classified as environmentally hazardous. However, this does not exclude the possibility that large or frequent spills can have a harmful or damaging effect on the environment.

| Components | Species | Test Results |
|---|--|---|
| Zinc oxide (CAS 1314-13-2) | | |
| Aquatic | | |
| Fish | LC50 | Fathead minnow (<i>Pimephales promelas</i>) 2246 mg/l, 96 hours |
| Persistence and degradability | No data is available on the degradability of this product. | |
| Bioaccumulative potential | No data available. | |
| Mobility in soil | No data available. | |
| Other adverse effects | None known. | |
| 13. Disposal considerations | | |
| Disposal instructions | Collect and reclaim or dispose in sealed containers at licensed waste disposal site. | |
| Local disposal regulations | Dispose in accordance with all applicable regulations. | |
| Hazardous waste code | The waste code should be assigned in discussion between the user, the producer and the waste disposal company. | |
| Waste from residues / unused products | Dispose of in accordance with local regulations. Empty containers or liners may retain some product residues. This material and its container must be disposed of in a safe manner (see: Disposal instructions). | |
| Contaminated packaging | Empty containers should be taken to an approved waste handling site for recycling or disposal. Since emptied containers may retain product residue, follow label warnings even after container is emptied. | |
| 14. Transport information | | |
| DOT | | |
| Not regulated as dangerous goods. | | |
| IATA | | |
| Not regulated as dangerous goods. | | |
| IMDG | | |
| Not regulated as dangerous goods. | | |
| Transport in bulk according to Annex II of MARPOL 73/78 and the IBC Code | Not applicable. | |
| 15. Regulatory information | | |
| US federal regulations | All components are on the U.S. EPA TSCA Inventory List. This product is not known to be a "Hazardous Chemical" as defined by the OSHA Hazard Communication Standard, 29 CFR 1910.1200. | |
| TSCA Section 12(b) Export Notification (40 CFR 707, Subpt. D) | | |
| Not regulated. | | |
| CERCLA Hazardous Substance List (40 CFR 302.4) | | |
| Not listed. | | |
| SARA 304 Emergency release notification | | |
| Not regulated. | | |
| OSHA Specifically Regulated Substances (29 CFR 1910.1001-1050) | | |
| Not listed. | | |
| Superfund Amendments and Reauthorization Act of 1986 (SARA) | | |
| Hazard categories | Immediate Hazard - No Delayed Hazard - No Fire Hazard - No Pressure Hazard - No Reactivity Hazard - No | |
| SARA 302 Extremely hazardous substance | | |
| Not listed. | | |
| SARA 311/312 Hazardous chemical | No | |
| SARA 313 (TRI reporting) | | |
| Not regulated. | | |

Other federal regulations

Clean Air Act (CAA) Section 112 Hazardous Air Pollutants (HAPs) List

Not regulated.

Clean Air Act (CAA) Section 112(r) Accidental Release Prevention (40 CFR 68.130)

Not regulated.

Safe Drinking Water Act (SDWA)

Not regulated.

US state regulations

US. California Controlled Substances. CA Department of Justice (California Health and Safety Code Section 11100)

Not listed.

US. Massachusetts RTK - Substance List

Molybdenum (IV) sulfide (CAS 1317-33-5)

Zinc oxide (CAS 1314-13-2)

US. New Jersey Worker and Community Right-to-Know Act

Zinc oxide (CAS 1314-13-2)

US. Pennsylvania Worker and Community Right-to-Know Law

Zinc oxide (CAS 1314-13-2)

US. Rhode Island RTK

Not regulated.

US. California Proposition 65

California Safe Drinking Water and Toxic Enforcement Act of 1986 (Proposition 65): This material is not known to contain any chemicals currently listed as carcinogens or reproductive toxins.

International Inventories

| Country(s) or region | Inventory name | On inventory (yes/no)* |
|-----------------------------|--|------------------------|
| Australia | Australian Inventory of Chemical Substances (AICS) | No |
| Canada | Domestic Substances List (DSL) | Yes |
| Canada | Non-Domestic Substances List (NDSL) | No |
| China | Inventory of Existing Chemical Substances in China (IECSC) | Yes |
| Europe | European Inventory of Existing Commercial Chemical Substances (EINECS) | Yes |
| Europe | European List of Notified Chemical Substances (ELINCS) | No |
| Japan | Inventory of Existing and New Chemical Substances (ENCS) | No |
| Korea | Existing Chemicals List (ECL) | No |
| New Zealand | New Zealand Inventory | Yes |
| Philippines | Philippine Inventory of Chemicals and Chemical Substances (PICCS) | Yes |
| United States & Puerto Rico | Toxic Substances Control Act (TSCA) Inventory | Yes |

*A "Yes" indicates that all components of this product comply with the inventory requirements administered by the governing country(s)

A "No" indicates that one or more components of the product are not listed or exempt from listing on the inventory administered by the governing country(s).

16. Other information, including date of preparation or last revision

Issue date 11-12-2014

Version # 01

Disclaimer LPS Laboratories cannot anticipate all conditions under which this information and its product, or the products of other manufacturers in combination with its product, may be used. It is the user's responsibility to ensure safe conditions for handling, storage and disposal of the product, and to assume liability for loss, injury, damage or expense due to improper use. The information provided in this Safety Data Sheet is correct to the best of our knowledge, information and belief at the date of its publication. The information given is designed only as a guidance for safe handling, use, processing, storage, transportation, disposal and release and is not to be considered a warranty or quality specification. The information relates only to the specific material designated and may not be valid for such material used in combination with any other materials or in any process, unless specified in the text.



Product Name: MOBIL VACTRA OIL HEAVY MEDIUM
 Revision Date: 16 Mar 2015
 Page 1 of 10

SAFETY DATA SHEET

SECTION 1 PRODUCT AND COMPANY IDENTIFICATION

PRODUCT

Product Name: MOBIL VACTRA OIL HEAVY MEDIUM
Product Description: Base Oil and Additives
Product Code: 201560503060, 580407-00, 970015
Intended Use: Lubricant

COMPANY IDENTIFICATION

Supplier: EXXON MOBIL CORPORATION
 22777 Springwoods Village Parkway
 Spring, TX. 77389 USA
24 Hour Health Emergency 609-737-4411
Transportation Emergency Phone 800-424-9300 or 703-527-3887 CHEMTREC
Product Technical Information 800-662-4525
MSDS Internet Address <http://www.exxon.com>, <http://www.mobil.com>

SECTION 2 HAZARDS IDENTIFICATION

This material is not hazardous according to regulatory guidelines (see (M)SDS Section 15).

Other hazard information:

HAZARD NOT OTHERWISE CLASSIFIED (HNOC): None as defined under 29 CFR 1910.1200.

PHYSICAL / CHEMICAL HAZARDS

No significant hazards.

HEALTH HAZARDS

High-pressure injection under skin may cause serious damage. Excessive exposure may result in eye, skin, or respiratory irritation.

ENVIRONMENTAL HAZARDS

No significant hazards.

| | | | |
|------------------------|-----------|-----------------|---------------|
| NFPA Hazard ID: | Health: 0 | Flammability: 1 | Reactivity: 0 |
| HMIS Hazard ID: | Health: 0 | Flammability: 1 | Reactivity: 0 |

NOTE: This material should not be used for any other purpose than the intended use in Section 1 without expert advice. Health studies have shown that chemical exposure may cause potential human health risks which may vary from person to person.



Product Name: MOBIL VACTRA OIL HEAVY MEDIUM
Revision Date: 16 Mar 2015
Page 2 of 10

SECTION 3 COMPOSITION / INFORMATION ON INGREDIENTS

This material is defined as a mixture.

Hazardous Substance(s) or Complex Substance(s) required for disclosure

| Name | CAS# | Concentration* | GHS Hazard Codes |
|------------------------|----------|----------------|--|
| 2,6-DITERTBUTYL PHENOL | 128-39-2 | 0.1 - < 0.25% | H315, H319(2A), H400(M factor 1), H410(M factor 1) |

* All concentrations are percent by weight unless material is a gas. Gas concentrations are in percent by volume.

As per paragraph (i) of 29 CFR 1910.1200, formulation is considered a trade secret and specific chemical identity and exact percentage (concentration) of composition may have been withheld. Specific chemical identity and exact percentage composition will be provided to health professionals, employees, or designated representatives in accordance with applicable provisions of paragraph (i).

SECTION 4 FIRST AID MEASURES

INHALATION

Remove from further exposure. For those providing assistance, avoid exposure to yourself or others. Use adequate respiratory protection. If respiratory irritation, dizziness, nausea, or unconsciousness occurs, seek immediate medical assistance. If breathing has stopped, assist ventilation with a mechanical device or use mouth-to-mouth resuscitation.

SKIN CONTACT

Wash contact areas with soap and water. If product is injected into or under the skin, or into any part of the body, regardless of the appearance of the wound or its size, the individual should be evaluated immediately by a physician as a surgical emergency. Even though initial symptoms from high pressure injection may be minimal or absent, early surgical treatment within the first few hours may significantly reduce the ultimate extent of injury.

EYE CONTACT

Flush thoroughly with water. If irritation occurs, get medical assistance.

INGESTION

First aid is normally not required. Seek medical attention if discomfort occurs.

SECTION 5 FIRE FIGHTING MEASURES

EXTINGUISHING MEDIA

Appropriate Extinguishing Media: Use water fog, foam, dry chemical or carbon dioxide (CO2) to extinguish flames.

Inappropriate Extinguishing Media: Straight Streams of Water

FIRE FIGHTING



Product Name: MOBIL VACTRA OIL HEAVY MEDIUM
 Revision Date: 16 Mar 2015
 Page 3 of 10

Fire Fighting Instructions: Evacuate area. Prevent runoff from fire control or dilution from entering streams, sewers, or drinking water supply. Firefighters should use standard protective equipment and in enclosed spaces, self-contained breathing apparatus (SCBA). Use water spray to cool fire exposed surfaces and to protect personnel.

Hazardous Combustion Products: Smoke, Fume, Sulfur oxides, Aldehydes, Oxides of carbon, Incomplete combustion products

FLAMMABILITY PROPERTIES

Flash Point [Method]: >204°C (399°F) [ASTM D-92]

Flammable Limits (Approximate volume % in air): LEL: 0.9 UEL: 7.0

Autoignition Temperature: N/D

SECTION 6 ACCIDENTAL RELEASE MEASURES

NOTIFICATION PROCEDURES

In the event of a spill or accidental release, notify relevant authorities in accordance with all applicable regulations. US regulations require reporting releases of this material to the environment which exceed the applicable reportable quantity or oil spills which could reach any waterway including intermittent dry creeks. The National Response Center can be reached at (800)424-8802.

PROTECTIVE MEASURES

Avoid contact with spilled material. See Section 5 for fire fighting information. See the Hazard Identification Section for Significant Hazards. See Section 4 for First Aid Advice. See Section 8 for advice on the minimum requirements for personal protective equipment. Additional protective measures may be necessary, depending on the specific circumstances and/or the expert judgment of the emergency responders.

For emergency responders: Respiratory protection: respiratory protection will be necessary only in special cases, e.g., formation of mists. Half-face or full-face respirator with filter(s) for dust/organic vapor or Self Contained Breathing Apparatus (SCBA) can be used depending on the size of spill and potential level of exposure. If the exposure cannot be completely characterized or an oxygen deficient atmosphere is possible or anticipated, SCBA is recommended. Work gloves that are resistant to hydrocarbons are recommended. Gloves made of polyvinyl acetate (PVA) are not water-resistant and are not suitable for emergency use. Chemical goggles are recommended if splashes or contact with eyes is possible. Small spills: normal antistatic work clothes are usually adequate. Large spills: full body suit of chemical resistant, antistatic material is recommended.

SPILL MANAGEMENT

Land Spill: Stop leak if you can do it without risk. Recover by pumping or with suitable absorbent.

Water Spill: Stop leak if you can do it without risk. Confine the spill immediately with booms. Warn other shipping. Remove from the surface by skimming or with suitable absorbents. Seek the advice of a specialist before using dispersants.

Water spill and land spill recommendations are based on the most likely spill scenario for this material; however, geographic conditions, wind, temperature, (and in the case of a water spill) wave and current direction and speed may greatly influence the appropriate action to be taken. For this reason, local experts should be consulted. Note: Local regulations may prescribe or limit action to be taken.

ENVIRONMENTAL PRECAUTIONS

Large Spills: Dike far ahead of liquid spill for later recovery and disposal. Prevent entry into waterways,

sewers, basements or confined areas.

| | |
|------------------|-----------------------------|
| SECTION 7 | HANDLING AND STORAGE |
|------------------|-----------------------------|

HANDLING

Prevent small spills and leakage to avoid slip hazard. Material can accumulate static charges which may cause an electrical spark (ignition source). When the material is handled in bulk, an electrical spark could ignite any flammable vapors from liquids or residues that may be present (e.g., during switch-loading operations). Use proper bonding and/or ground procedures. However, bonding and grounds may not eliminate the hazard from static accumulation. Consult local applicable standards for guidance. Additional references include American Petroleum Institute 2003 (Protection Against Ignitions Arising out of Static, Lightning and Stray Currents) or National Fire Protection Agency 77 (Recommended Practice on Static Electricity) or CENELEC CLC/TR 50404 (Electrostatics - Code of practice for the avoidance of hazards due to static electricity).

Static Accumulator: This material is a static accumulator.

STORAGE

The container choice, for example storage vessel, may effect static accumulation and dissipation. Do not store in open or unlabelled containers. Keep away from incompatible materials.

| | |
|------------------|--|
| SECTION 8 | EXPOSURE CONTROLS / PERSONAL PROTECTION |
|------------------|--|

Exposure limits/standards for materials that can be formed when handling this product: When mists/aerosols can occur the following are recommended: 5 mg/m³ - ACGIH TLV (inhalable fraction), 5 mg/m³ - OSHA PEL.

NOTE: Limits/standards shown for guidance only. Follow applicable regulations.

No biological limits allocated.

ENGINEERING CONTROLS

The level of protection and types of controls necessary will vary depending upon potential exposure conditions. Control measures to consider:
No special requirements under ordinary conditions of use and with adequate ventilation.

PERSONAL PROTECTION

Personal protective equipment selections vary based on potential exposure conditions such as applications, handling practices, concentration and ventilation. Information on the selection of protective equipment for use with this material, as provided below, is based upon intended, normal usage.

Respiratory Protection: If engineering controls do not maintain airborne contaminant concentrations at a level which is adequate to protect worker health, an approved respirator may be appropriate. Respirator selection, use, and maintenance must be in accordance with regulatory requirements, if applicable. Types of respirators to be considered for this material include:

No special requirements under ordinary conditions of use and with adequate ventilation.



Product Name: MOBIL VACTRA OIL HEAVY MEDIUM
 Revision Date: 16 Mar 2015
 Page 5 of 10

For high airborne concentrations, use an approved supplied-air respirator, operated in positive pressure mode. Supplied air respirators with an escape bottle may be appropriate when oxygen levels are inadequate, gas/vapor warning properties are poor, or if air purifying filter capacity/rating may be exceeded.

Hand Protection: Any specific glove information provided is based on published literature and glove manufacturer data. Glove suitability and breakthrough time will differ depending on the specific use conditions. Contact the glove manufacturer for specific advice on glove selection and breakthrough times for your use conditions. Inspect and replace worn or damaged gloves. The types of gloves to be considered for this material include:

No protection is ordinarily required under normal conditions of use.

Eye Protection: If contact is likely, safety glasses with side shields are recommended.

Skin and Body Protection: Any specific clothing information provided is based on published literature or manufacturer data. The types of clothing to be considered for this material include:

No skin protection is ordinarily required under normal conditions of use. In accordance with good industrial hygiene practices, precautions should be taken to avoid skin contact.

Specific Hygiene Measures: Always observe good personal hygiene measures, such as washing after handling the material and before eating, drinking, and/or smoking. Routinely wash work clothing and protective equipment to remove contaminants. Discard contaminated clothing and footwear that cannot be cleaned. Practice good housekeeping.

ENVIRONMENTAL CONTROLS

Comply with applicable environmental regulations limiting discharge to air, water and soil. Protect the environment by applying appropriate control measures to prevent or limit emissions.

| | |
|------------------|---|
| SECTION 9 | PHYSICAL AND CHEMICAL PROPERTIES |
|------------------|---|

Note: Physical and chemical properties are provided for safety, health and environmental considerations only and may not fully represent product specifications. Contact the Supplier for additional information.

GENERAL INFORMATION

Physical State: Liquid
Color: Amber
Odor: Characteristic
Odor Threshold: N/D

IMPORTANT HEALTH, SAFETY, AND ENVIRONMENTAL INFORMATION

Relative Density (at 15 °C): 0.882
Flammability (Solid, Gas): N/A
Flash Point [Method]: >204°C (399°F) [ASTM D-92]
Flammable Limits (Approximate volume % in air): LEL: 0.9 UEL: 7.0
Autoignition Temperature: N/D
Boiling Point / Range: > 316°C (600°F)
Decomposition Temperature: N/D
Vapor Density (Air = 1): > 2 at 101 kPa
Vapor Pressure: < 0.013 kPa (0.1 mm Hg) at 20 °C
Evaporation Rate (n-butyl acetate = 1): N/D



Product Name: MOBIL VACTRA OIL HEAVY MEDIUM
Revision Date: 16 Mar 2015
Page 6 of 10

pH: N/A
Log Pow (n-Octanol/Water Partition Coefficient): > 3.5
Solubility in Water: Negligible
Viscosity: >68 cSt (68 mm²/sec) at 40 °C
Oxidizing Properties: See Hazards Identification Section.

OTHER INFORMATION

Freezing Point: N/D
Melting Point: N/A
Pour Point: -15°C (5°F)
DMSO Extract (mineral oil only), IP-346: < 3 %wt

SECTION 10 STABILITY AND REACTIVITY

REACTIVITY: See sub-sections below.

STABILITY: Material is stable under normal conditions.

CONDITIONS TO AVOID: Excessive heat. High energy sources of ignition.

MATERIALS TO AVOID: Strong oxidizers

HAZARDOUS DECOMPOSITION PRODUCTS: Material does not decompose at ambient temperatures.

POSSIBILITY OF HAZARDOUS REACTIONS: Hazardous polymerization will not occur.

SECTION 11 TOXICOLOGICAL INFORMATION

INFORMATION ON TOXICOLOGICAL EFFECTS

| Hazard Class | Conclusion / Remarks |
|--|---|
| Inhalation | |
| Acute Toxicity: No end point data for material. | Minimally Toxic. Based on assessment of the components. |
| Irritation: No end point data for material. | Negligible hazard at ambient/normal handling temperatures. |
| Ingestion | |
| Acute Toxicity: No end point data for material. | Minimally Toxic. Based on assessment of the components. |
| Skin | |
| Acute Toxicity: No end point data for material. | Minimally Toxic. Based on assessment of the components. |
| Skin Corrosion/Irritation: No end point data for material. | Negligible irritation to skin at ambient temperatures. Based on assessment of the components. |
| Eye | |
| Serious Eye Damage/Irritation: No end point data for material. | May cause mild, short-lasting discomfort to eyes. Based on assessment of the components. |
| Sensitization | |
| Respiratory Sensitization: No end point data for material. | Not expected to be a respiratory sensitizer. |
| Skin Sensitization: No end point data for material. | Not expected to be a skin sensitizer. Based on assessment of the components. |
| Aspiration: Data available. | Not expected to be an aspiration hazard. Based on |



Product Name: MOBIL VACTRA OIL HEAVY MEDIUM

Revision Date: 16 Mar 2015

Page 7 of 10

| | |
|--|--|
| | physico-chemical properties of the material. |
| Germ Cell Mutagenicity: No end point data for material. | Not expected to be a germ cell mutagen. Based on assessment of the components. |
| Carcinogenicity: No end point data for material. | Not expected to cause cancer. Based on assessment of the components. |
| Reproductive Toxicity: No end point data for material. | Not expected to be a reproductive toxicant. Based on assessment of the components. |
| Lactation: No end point data for material. | Not expected to cause harm to breast-fed children. |
| Specific Target Organ Toxicity (STOT) | |
| Single Exposure: No end point data for material. | Not expected to cause organ damage from a single exposure. |
| Repeated Exposure: No end point data for material. | Not expected to cause organ damage from prolonged or repeated exposure. Based on assessment of the components. |

OTHER INFORMATION

Contains:

Base oil severely refined: Not carcinogenic in animal studies. Representative material passes IP-346, Modified Ames test, and/or other screening tests. Dermal and inhalation studies showed minimal effects; lung non-specific infiltration of immune cells, oil deposition and minimal granuloma formation. Not sensitizing in test animals.

The following ingredients are cited on the lists below: None.

--REGULATORY LISTS SEARCHED--

1 = NTP CARC

3 = IARC 1

5 = IARC 2B

2 = NTP SUS

4 = IARC 2A

6 = OSHA CARC

SECTION 12 ECOLOGICAL INFORMATION

The information given is based on data available for the material, the components of the material, and similar materials.

ECOTOXICITY

Material -- Not expected to be harmful to aquatic organisms.

MOBILITY

Base oil component -- Low solubility and floats and is expected to migrate from water to the land. Expected to partition to sediment and wastewater solids.

PERSISTENCE AND DEGRADABILITY

Biodegradation:

Base oil component -- Expected to be inherently biodegradable

BIOACCUMULATION POTENTIAL

Base oil component -- Has the potential to bioaccumulate, however metabolism or physical properties may reduce the bioconcentration or limit bioavailability.



Product Name: MOBIL VACTRA OIL HEAVY MEDIUM
Revision Date: 16 Mar 2015
Page 8 of 10

SECTION 13 DISPOSAL CONSIDERATIONS

Disposal recommendations based on material as supplied. Disposal must be in accordance with current applicable laws and regulations, and material characteristics at time of disposal.

DISPOSAL RECOMMENDATIONS

Product is suitable for burning in an enclosed controlled burner for fuel value or disposal by supervised incineration at very high temperatures to prevent formation of undesirable combustion products. Protect the environment. Dispose of used oil at designated sites. Minimize skin contact. Do not mix used oils with solvents, brake fluids or coolants.

REGULATORY DISPOSAL INFORMATION

RCRA Information: The unused product, in our opinion, is not specifically listed by the EPA as a hazardous waste (40 CFR, Part 261D), nor is it formulated to contain materials which are listed as hazardous wastes. It does not exhibit the hazardous characteristics of ignitability, corrosivity or reactivity and is not formulated with contaminants as determined by the Toxicity Characteristic Leaching Procedure (TCLP). However, used product may be regulated.

Empty Container Warning Empty Container Warning (where applicable): Empty containers may contain residue and can be dangerous. Do not attempt to refill or clean containers without proper instructions. Empty drums should be completely drained and safely stored until appropriately reconditioned or disposed. Empty containers should be taken for recycling, recovery, or disposal through suitably qualified or licensed contractor and in accordance with governmental regulations. **DO NOT PRESSURISE, CUT, WELD, BRAZE, SOLDER, DRILL, GRIND, OR EXPOSE SUCH CONTAINERS TO HEAT, FLAME, SPARKS, STATIC ELECTRICITY, OR OTHER SOURCES OF IGNITION. THEY MAY EXPLODE AND CAUSE INJURY OR DEATH.**

SECTION 14 TRANSPORT INFORMATION

LAND (DOT): Not Regulated for Land Transport

LAND (TDG): Not Regulated for Land Transport

SEA (IMDG): Not Regulated for Sea Transport according to IMDG-Code

Marine Pollutant: No

AIR (IATA): Not Regulated for Air Transport

SECTION 15 REGULATORY INFORMATION



Product Name: MOBIL VACTRA OIL HEAVY MEDIUM
 Revision Date: 16 Mar 2015
 Page 9 of 10

OSHA HAZARD COMMUNICATION STANDARD: This material is not considered hazardous in accordance with OSHA HazCom 2012, 29 CFR 1910.1200.

Listed or exempt from listing/notification on the following chemical inventories: AICS, DSL, IECSC, TSCA

EPCRA SECTION 302: This material contains no extremely hazardous substances.

SARA (311/312) REPORTABLE HAZARD CATEGORIES: None.

SARA (313) TOXIC RELEASE INVENTORY: This material contains no chemicals subject to the supplier notification requirements of the SARA 313 Toxic Release Program.

The following ingredients are cited on the lists below: None.

--REGULATORY LISTS SEARCHED--

| | | | |
|---------------|------------------|-------------------|-------------|
| 1 = ACGIH ALL | 6 = TSCA 5a2 | 11 = CA P65 REPRO | 16 = MN RTK |
| 2 = ACGIH A1 | 7 = TSCA 5e | 12 = CA RTK | 17 = NJ RTK |
| 3 = ACGIH A2 | 8 = TSCA 6 | 13 = IL RTK | 18 = PA RTK |
| 4 = OSHA Z | 9 = TSCA 12b | 14 = LA RTK | 19 = RI RTK |
| 5 = TSCA 4 | 10 = CA P65 CARC | 15 = MI 293 | |

Code key: CARC=Carcinogen; REPRO=Reproductive

| SECTION 16 | OTHER INFORMATION |
|------------|-------------------|
|------------|-------------------|

N/D = Not determined, N/A = Not applicable

KEY TO THE H-CODES CONTAINED IN SECTION 3 OF THIS DOCUMENT (for information only):

H315: Causes skin irritation; Skin Corr/Irritation, Cat 2

H319(2A): Causes serious eye irritation; Serious Eye Damage/Irr, Cat 2A

H400: Very toxic to aquatic life; Acute Env Tox, Cat 1

H410: Very toxic to aquatic life with long lasting effects; Chronic Env Tox, Cat 1

THIS SAFETY DATA SHEET CONTAINS THE FOLLOWING REVISIONS:

Updates made in accordance with implementation of GHS requirements.

 The information and recommendations contained herein are, to the best of ExxonMobil's knowledge and belief, accurate and reliable as of the date issued. You can contact ExxonMobil to insure that this document is the most current available from ExxonMobil. The information and recommendations are offered for the user's consideration and examination. It is the user's responsibility to satisfy itself that the product is suitable for the intended use. If buyer repackages this product, it is the user's responsibility to insure proper health, safety and other necessary information is included with and/or on the container. Appropriate warnings and safe-handling procedures should be provided to



Product Name: MOBIL VACTRA OIL HEAVY MEDIUM
Revision Date: 16 Mar 2015
Page 10 of 10

handlers and users. Alteration of this document is strictly prohibited. Except to the extent required by law, re-publication or retransmission of this document, in whole or in part, is not permitted. The term, "ExxonMobil" is used for convenience, and may include any one or more of ExxonMobil Chemical Company, Exxon Mobil Corporation, or any affiliates in which they directly or indirectly hold any interest.

Internal Use Only
MHC: 0B, 0B, 0, 0, 0, 0 PPEC: A
DGN: 2006644XUS (1017266)

Copyright 2002 Exxon Mobil Corporation, All rights reserved

SAF-T-LOK

International Corporation

Material Safety Data Sheet

SAF-T-EZE MOLY GRADE ANTI-SEIZE

Issue Date: 10/30/14

SECTION I - PRODUCT AND COMPANY INFORMATION

| | |
|----------------------------|---|
| Product Name: | MOLY GRADE ANTI-SEIZE |
| Product Type: | Lubricating Grease |
| Part Numbers: | 80855, 80837, 80822, 80878, 80853, 6V-4876 |
| Hazard Rating: | Health: 1 Fire: 1 Reactivity: 0 |
| Company Identification: | SAF-T-LOK International Corporation 300 EISENHOWER LANE NORTH LOMBARD, IL 60148 |
| Contact: | Chris Michaels |
| Telephone/ Fax: | (630) 495-2001 |
| Emergency Phone (24 Hour): | (703) 527-3887 |
| Chemtrec (24 Hour): | (800) 424-9300, (703) 527-3887 |
| Preparer: | Ind. Hygiene Department |
| Internet: | www.saftlok.com |
| Product Class: | Mixture |
| DOT Hazard Class: | N/A |
| Shipping Name: | Unrestricted |

SECTION II - INGREDIENT AND HAZARD INFORMATION

| Components | CAS Number | Percent |
|---|------------|---------|
| Graphite | 7782-42-5 | 20 - 30 |
| Hydrotreated Heavy Napthenic Distillate | 64742-52-5 | 40 - 50 |
| Molybdenum Disulfide | 1317-33-5 | 20 - 30 |

SECTION III - HAZARD IDENTIFICATION AND EMERGENCY OVERVIEWEMERGENCY OVERVIEW

| | | | |
|----------------------|--------------------|----------------------|---|
| Physical appearance: | Paste | <u>HMS</u> | |
| Physical color: | Black | Health: | 1 |
| Odor: | Mild / Inoffensive | Flammability: | 1 |
| | | Reactivity: | 0 |
| | | Personal Protection: | B |

WARNING; MAY CAUSE: EYE IRRITATION
SKIN IRRITATION
RESPIRATORY TRACT IRRITATION
MAY IRRITATE EXISTING ALLERGIC SKIN CONDITIONS

Relative routes of entry: Skin, Inhalation, Eyes, Ingestion

Skin Contact: Usually no effect, however, as with any chemical, prolonged, excessive, or repeated exposure may cause mild to moderate skin irritation, exhibited by redness, drying and cracking of unprotected skin.
Eye Contact: May irritate with slight pain and redness.

Respiratory/ Inhalation: Usually none, however, as with any chemical product, some irritation may occur.

Ingestion: Amounts transferred to mouth by fingers, etc, during normal operation should not cause injury.

Medical conditions generally aggravated by exposure: None known, however any chemical product may enhance allergies already present in certain individuals.

This product does not require exceptional labeling due to the evaluation procedure of the "General Classification guideline for preparations of the EU".

SECTION IV – FIRST AID INSTRUCTIONS

Skin Contact: Remove contaminated clothing. Wash affected area with soap and rinse with plenty of water. Get medical attention if symptoms occur. Wash clothing before reuse.

Eye Contact: Flush with water for at least 15 minutes holding eyelid open. Get medical attention if symptoms persist.

Respiratory / Inhalation: Remove to fresh air, if symptoms develop get medical attention.

Ingestion: Do not induce vomiting. Obtain medical attention if symptoms develop.

SECTION V – FIRE FIGHTING INSTRUCTIONS

| | |
|-------------------------------------|--|
| Flash Point: | 360°F (C.O.C.) |
| Unusual Fire and Explosion Hazards: | None |
| Flammable Limits: | LEL: N/A, UEL: N/A |
| Extinguishing Media: | Carbon Dioxide, Foam, Dry Chemicals |
| Fire Fighting Procedures: | Air mask and procedures for fighting chemical fires. Do not inhale gases. |

SECTION VI -ACCIDENTAL RELEASE MEASURES

Special Precautions: None known. Follow general precautions shown below.

Environmental precautions: Prevent material from entering floor drains, sewers, or any bodies of water.

Clean up methods: Scoop up into waste container or soak up with absorbent material. Store in a closed container until disposal. Dispose of material according to regulations.

SECTION VII - HANDLING AND STORAGE

Handling: No special precautions necessary if used properly. Avoid contact with eyes, skin, and clothing. Avoid breathing vapors. Wash hands thoroughly at mealtime and end of shift.

| | |
|----------------------|--|
| Storage: | Isolated storage facility/ warehouse not required. Store in a cool, dry location (60-90°F) in a well-ventilated area in original container. Keep container tightly closed when not in use. |
| Personal Protection: | Wear personal protective equipment as outlined in Section VIII of this MSDS. |

SECTION VIII – EXPOSURE CONTROLS AND PERSONAL PROTECTION

| | |
|-------------------------|--|
| Respiratory Protection: | No respiratory protection required, but normal good ventilation is recommended. Forced ventilation may be required if concentrations exceed normal use exposure. |
| Skin Protection: | Not required, but if desired, use impermeable gloves (neoprene, butyl rubber, natural rubber), as necessary to avoid skin contact, as well as proper clothing or plastic apron. Wash hands before eating, drinking, or using restroom. |
| Eye Protection: | Not required if application method is proper. Avoid contact with eyes. |
| Eye Washes: | Eye wash stations should be located within 100 feet or 10 second walk of the work area. |

SECTION IX - PHYSICAL AND CHEMICAL PROPERTIES

| | |
|--------------------------|----------------------|
| Physical state: | Paste |
| Color: | Black |
| Odor: | Mild/ Inoffensive |
| Boiling Point: | 600°F (316°C) |
| Melting Point: | Not determined |
| Flash Point: | 360°F |
| Self-inflammability: | Is not self-igniting |
| Explosion danger: | Not explosive |
| Specific Gravity: | 1.4 |
| Vapor Density (Air = 1): | N/D |
| Vapor Pressure (mm Hg.): | < 0.1 @70°F |
| pH: | Not determined |
| Evaporation Rate: | Not determined |
| Solubility in Water: | Insoluble |
| VOC (Organic solvents): | 0.1% |
| Percent Solids: | 50 |

SECTION X – STABILITY AND REACTIVITY

| | |
|-------------------------------------|---|
| Stability: | Stable |
| Hazardous Polymerization: | Will not occur |
| Hazardous decomposition byproducts: | None if used and stored according to specifications |
| Conditions to avoid: | Strong oxidizing agents |

SECTION XI – TOXICOLOGICAL INFORMATION

No harmful effects have been determined if product is used and handled according to specifications.

This product is not subject to classification according to the calculation method of the General EC Classification Guidelines for Preparations.

| | |
|----------------|----------------|
| Sensitization: | None known |
| Eye Irritant: | Not determined |
| Skin Irritant: | Not determined |
| Carcinogen: | No |

SECTION XII – ECOLOGICAL DATA

Water Hazard: Do not allow entry into drains or surface water
Class 2 per German Regulation

SECTION XIII – DISPOSAL CONSIDERATIONS

Recommended method of disposal: Small quantities can be disposed with normal household waste.
Disposal must be made according to official regulations.

EPA Hazardous Waste Number; Not an RCRA hazardous waste.

SECTION XIV – SHIPPING AND TRANSPORTATION INFORMATION

U.S. Department of Transportation Ground (49 CFR)
Proper Shipping Name: Unrestricted
Hazard Class or Division: None
Identification Number: None
Packing Group: None

International Air Transportation (OCAO/IATA):
Proper Shipping Name: Unrestricted
Hazard Class or Division: None
Identification Number: None
Packing Group: None

Water Transportation (IMO/IMDG):
Proper Shipping Name: Environmentally hazardous substance, liquid, N.O. S.
Hazard Class or Division: IMDG Class 9
Identification Number: None
Packing Group: None
Marine Pollutant: Yes

ADR/RID-GGVS/E Class (cross border) Unrestricted

SECTION XV – REGULATORY INFORMATION

United States Regulatory Information

TSCA 8 (b) Inventory Status: All components are listed or are exempt from listing on the Toxic Substances Control Act Inventory

Canada Regulatory Information

CEPA DSL/NDL Status: All components are listed on or are exempt from listing on the Domestic Substances List.

SECTION XVI – OTHER INFORMATION

Revision date: 10/30/14
By: Human Resource Department

DISCLAIMER: The information on this material safety data sheet represents our current data and best opinion as to the proper use in handling of this product under normal conditions. Any use of the product which is not in conformance with this data sheet or which involves using the product in combination with any other product or any other process is the responsibility of the user. SAF-T-LOK International Corporation specifically disclaims all warranties, express or implied, including warranties of merchantability and fitness for a particular purpose, arising from sale or use of SAF-T-LOK International Corporation products.

Product Name: Nook Industries E-900L Liquid
(Part number NLU-1004)
Revision Date: 23 Sept 2013
Page 1 of 7



MATERIAL SAFETY DATA SHEET

SECTION 1 PRODUCT AND COMPANY IDENTIFICATION

PRODUCT

Product Name: Nook Industries E-900L Ball Screw Lubricant Liquid
Product Description: Synthetic Base Stocks and Additives
Product Code: 202050401020, 494237-00, 971870
Intended Use: Ball screw lubrication

COMPANY IDENTIFICATION

Supplier: **NOOK INDUSTRIES**
 4950 EAST 49th STREET
 CLEVELAND, OH 44125

24 Hour Health Emergency 800-255-3924
MSDS Requests 800-321-7800
MSDS Internet Address <http://www.nookindustries.com/r/msds>

SECTION 2 COMPOSITION / INFORMATION ON INGREDIENTS

REPORTABLE HAZARDOUS SUBSTANCE(S) OR COMPLEX SUBSTANCE(S)

| NAME | CAS# | CONCENTRATION* |
|----------------------------|---------|----------------|
| 1-NAPHTHYLAMINE, N-PHENYL- | 90-30-2 | 1% |

* All concentrations are percent by weight unless material is a gas. Gas concentrations are in percent by volume.

SECTION 3 HAZARDS IDENTIFICATION

This material is not considered to be hazardous according to regulatory guidelines (see (MSDS Section 15)).

POTENTIAL HEALTH EFFECTS

Excessive exposure may result in eye, skin, or respiratory irritation. This product is not expected to produce adverse health effects under normal conditions of use and with appropriate personal hygiene practices. Product may decompose at elevated temperatures or under fire conditions and give off irritating and/or harmful (carbon monoxide) gases/vapors/fumes. Symptoms from acute exposure to these decomposition products in confined spaces may include headache, nausea, eye, nose, and throat irritation. High-pressure injection under skin may cause serious damage.

| NFPA HAZARD ID: | HEALTH: 1 | FLAMMABILITY: 1 | REACTIVITY: 0 |
|-----------------|-----------|-----------------|---------------|
| HMIS Hazard ID: | Health: 1 | Flammability: 1 | Reactivity: 0 |

NOTE: This material should not be used for any other purpose than the intended use in Section 1 without expert advice. Health studies have shown that chemical exposure may cause potential human health risks which may vary from person to person.

Product Name: Nook Industries E-900L Liquid
(Part number NLU-1004)
Revision Date: 23 Sept 2013
Page 2 of 7



SECTION 4 FIRST AID MEASURES

INHALATION

Remove from further exposure. For those providing assistance, avoid exposure to yourself or others. Use adequate respiratory protection. If respiratory irritation, dizziness, nausea, or unconsciousness occurs, seek immediate medical assistance. If breathing has stopped, assist ventilation with a mechanical device or use mouth-to-mouth resuscitation.

SKIN CONTACT

Wash contact areas with soap and water. If product is injected into or under the skin, or into any part of the body, regardless of the appearance of the wound or its size, the individual should be evaluated immediately by a physician as a surgical emergency. Even though initial symptoms from high pressure injection may be minimal or absent, early surgical treatment within the first few hours may significantly reduce the ultimate extent of injury.

EYE CONTACT

Flush thoroughly with water. If irritation occurs, get medical assistance.

INGESTION

Seek immediate medical attention.

SECTION 5 FIRE FIGHTING MEASURES

EXTINGUISHING MEDIA

Appropriate Extinguishing Media: Use water fog, foam, dry chemical or carbon dioxide (CO₂) to extinguish flames.

Inappropriate Extinguishing Media: Straight Streams of Water

FIRE FIGHTING

Fire Fighting Instructions: Evacuate area. Prevent runoff from fire control or dilution from entering streams, sewers, or drinking water supply. Firefighters should use standard protective equipment and in enclosed spaces, self-contained breathing apparatus (SCBA). Use water spray to cool fire exposed surfaces and to protect personnel.

Hazardous Combustion Products: Aldehydes, Smoke, Fume, Oxides of carbon, Sulfur oxides, Incomplete combustion products, Trimethylol propane phosphate

FLAMMABILITY PROPERTIES

Flash Point [Method]: 210C (410F) [ASTM D-92]

Flammable Limits (Approx vol % in air): LEL: N/D UEL: N/D

Autoignition Temperature: N/D

Product Name: Nook Industries E-900L Liquid
(Part number NLU-1004)
Revision Date: 23 Sept 2013
Page 3 of 7



SECTION 6 ACCIDENTAL RELEASE MEASURES

NOTIFICATION PROCEDURES

In the event of a spill or accidental release, notify relevant authorities in accordance with all applicable regulations. US regulations require reporting releases of this material to the environment which exceed the applicable reportable quantity or oil spills which could reach any waterway including intermittent dry creeks. The National Response Center can be reached at (800)424-8802.

SPILL MANAGEMENT

Land Spill: Stop leak if you can do it without risk. Recover by pumping or with suitable absorbent.

Water Spill: Stop leak if you can do it without risk. Confine the spill immediately with booms. Warn other shipping. Remove from the surface by skimming or with suitable absorbents. Seek the advice of a specialist before using dispersants.

Water spill and land spill recommendations are based on the most likely spill scenario for this material; however, geographic conditions, wind, temperature, (and in the case of a water spill) wave and current direction and speed may greatly influence the appropriate action to be taken. For this reason, local experts should be consulted. Note: Local regulations may prescribe or limit action to be taken.

ENVIRONMENTAL PRECAUTIONS

Large Spills: Dike far ahead of liquid spill for later recovery and disposal. Prevent entry into waterways, sewers, basements or confined areas.

SECTION 7 HANDLING AND STORAGE

HANDLING

It has been determined that during fires neurotoxic trimethylol propane phosphate may be formed, which when inhaled may impair central nervous system function. In addition, thermally decomposed (and cooled) residues may be neurotoxic. Prevent small spills and leakage to avoid slip hazard.

Static Accumulator: This material is a static accumulator.

STORAGE

Do not store in open or unlabelled containers.

SECTION 8 EXPOSURE CONTROLS / PERSONAL PROTECTION

NOTE: Limits/standards shown for guidance only. Follow applicable regulations.

ENGINEERING CONTROLS

The level of protection and types of controls necessary will vary depending upon potential exposure conditions. Control measures to consider:

No special requirements under ordinary conditions of use and with adequate ventilation.

PERSONAL PROTECTION

Personal protective equipment selections vary based on potential exposure conditions such as applications, handling practices, concentration and ventilation. Information on the selection of protective equipment for use with this material, as provided below, is based upon intended, normal usage.



Respiratory Protection: If engineering controls do not maintain airborne contaminant concentrations at a level which is adequate to protect worker health, an approved respirator may be appropriate. Respirator selection, use, and maintenance must be in accordance with regulatory requirements, if applicable. Types of respirators to be considered for this material include:

No special requirements under ordinary conditions of use and with adequate ventilation.

For high airborne concentrations, use an approved supplied-air respirator, operated in positive pressure mode. Supplied air respirators with an escape bottle may be appropriate when oxygen levels are inadequate, gas/vapor warning properties are poor, or if air purifying filter capacity/rating may be exceeded.

Hand Protection: Any specific glove information provided is based on published literature and glove manufacturer data. Glove suitability and breakthrough time will differ depending on the specific use conditions. Contact the glove manufacturer for specific advice on glove selection and breakthrough times for your use conditions. Inspect and replace worn or damaged gloves. The types of gloves to be considered for this material include:

No protection is ordinarily required under normal conditions of use.

Eye Protection: If contact is likely, safety glasses with side shields are recommended.

Skin and Body Protection: Any specific clothing information provided is based on published literature or manufacturer data. The types of clothing to be considered for this material include:

No skin protection is ordinarily required under normal conditions of use. In accordance with good industrial hygiene practices, precautions should be taken to avoid skin contact.

Specific Hygiene Measures: Always observe good personal hygiene measures, such as washing after handling the material and before eating, drinking, and/or smoking. Routinely wash work clothing and protective equipment to remove contaminants. Discard contaminated clothing and footwear that cannot be cleaned. Practice good housekeeping.

ENVIRONMENTAL CONTROLS

See Sections 6, 7, 12, 13.

SECTION 9 PHYSICAL AND CHEMICAL PROPERTIES

Typical physical and chemical properties are given below. Consult the Supplier in Section 1 for additional data.

GENERAL INFORMATION

| | |
|------------------------|----------------|
| Physical State: | Liquid |
| Color: | Amber |
| Odor: | Characteristic |
| Odor Threshold: | N/D |

IMPORTANT HEALTH, SAFETY, AND ENVIRONMENTAL INFORMATION

| | |
|--|---------------------------------|
| Relative Density (at 15 C): | 0.96 |
| Flash Point [Method]: | 210C (410F) [ASTM D-92] |
| Flammable Limits (Approx vol % in air): | LEL: N/D UEL: N/D |
| Autoignition Temperature: | N/D |
| Boiling Point / Range: | > 316C (600F) |
| Vapor Density (Air = 1): | N/D |
| Vapor Pressure: | < 0.013 kPa (0.1 mm Hg) at 20 C |
| Evaporation Rate (n-butyl acetate = 1): | N/D |
| pH: | N/A |

Product Name: Nook Industries E-900L Liquid
(Part number NLU-1004)
Revision Date: 23 Sept 2013
Page 5 of 7



Log Pow (n-Octanol/Water Partition Coefficient): N/A
Solubility in Water: Negligible
Viscosity: 13.3 cSt (13.3 mm²/sec) at 40 C | 3 cSt (3 mm²/sec) at 100C
Oxidizing Properties: See Sections 3, 15, 16.

OTHER INFORMATION

Freezing Point: N/D
Melting Point: N/A
Pour Point: -62°C (-80°F)

SECTION 10 STABILITY AND REACTIVITY

Stability: material is stable under normal conditions.
Conditions To Avoid: excessive heat. High energy sources of ignition.
Materials To Avoid: Strong oxidizers
Hazardous Decomposition Products: material does not decompose at ambient temperatures.
Hazardous Polymerization: will not occur.

SECTION 11 TOXICOLOGICAL INFORMATION

ACUTE TOXICITY

| ROUTE OF EXPOSURE | CONCLUSION / REMARKS |
|--------------------------------|---|
| Inhalation | |
| Toxicity: No end point data. | Not determined. |
| Irritation: No end point data. | Negligible hazard at ambient/normal handling temperatures. Based on assessment of the components. |
| | |
| Ingestion | |
| Toxicity: No end point data. | Minimally Toxic. Based on assessment of the components. |
| | |
| Skin | |
| Toxicity: No end point data. | Minimally Toxic. Based on assessment of the components. |
| Irritation: No end point data. | Negligible irritation to skin at ambient temperatures. Based on assessment of the components. |
| | |
| Eye | |
| Irritation: No end point data. | May cause mild, short-lasting discomfort to eyes. Based on assessment of the components. |
| | |

CHRONIC/OTHER EFFECTS

Contains:

N-phenyl-1-naphthylamine: A single oral overexposure may lead to signs of cyanosis, including headache, shallow respiration, dizziness, confusion, fall in blood pressure, convulsions, coma, jaundice.

Product Name: Nook Industries E-900L Liquid
(Part number NLU-1004)
Revision Date: 23 Sept 2013
Page 6 of 7



Anemia may occur later. Repeated exposure in laboratory animals caused liver and kidney damage and depression of bone marrow activity. Hematuria may occur due to bladder and kidney irritation. Genotoxic in vitro.

Phenyl-alpha-naphthylamine (PAN): Undiluted PAN is a skin sensitizer. Human testing with lubricants containing 1.0% PAN caused no reactions indicative of sensitization.

Additional information is available by request.

The following ingredients are cited on the lists below: None.

| --REGULATORY LISTS SEARCHED-- | | |
|-------------------------------|-------------|---------------|
| 1 = NTP CARC | 3 = IARC 1 | 5 = IARC 2B |
| 2 = NTP SUS | 4 = IARC 2A | 6 = OSHA CARC |

SECTION 12 ECOLOGICAL INFORMATION

The information given is based on data available for the material, the components of the material, and similar materials.

ECOTOXICITY

Material -- Not expected to be harmful to aquatic organisms.

Material -- Not expected to demonstrate chronic toxicity to aquatic organisms.

SECTION 13 DISPOSAL CONSIDERATIONS

Disposal recommendations based on material as supplied. Disposal must be in accordance with current applicable laws and regulations, and material characteristics at time of disposal.

DISPOSAL RECOMMENDATIONS

Dispose of waste at an appropriate treatment & disposal facility in accordance with applicable laws and regulations, and product characteristics at time of disposal.

REGULATORY DISPOSAL INFORMATION

RCRA Information: The unused product, in our opinion, is not specifically listed by the EPA as a hazardous waste (40 CFR, Part 261D), nor is it formulated to contain materials which are listed as hazardous wastes. It does not exhibit the hazardous characteristics of ignitability, corrosivity or reactivity and is not formulated with contaminants as determined by the Toxicity Characteristic Leaching Procedure (TCLP). However, used product may be regulated.

Empty Container Warning Empty Container Warning (where applicable): Empty containers may contain residue and can be dangerous. Do not attempt to refill or clean containers without proper instructions. Empty drums should be completely drained and safely stored until appropriately reconditioned or disposed. Empty containers should be taken for recycling, recovery, or disposal through suitably qualified or licensed contractor and in accordance with governmental regulations. DO NOT PRESSURISE, CUT, WELD, BRAZE, SOLDER, DRILL, GRIND, OR EXPOSE SUCH CONTAINERS TO HEAT, FLAME, SPARKS, STATIC ELECTRICITY, OR OTHER SOURCES OF IGNITION. THEY MAY EXPLODE AND CAUSE INJURY OR DEATH.

Product Name: Nook Industries E-900L Liquid
(Part number NLU-1004)
Revision Date: 23 Sept 2013
Page 7 of 7



SECTION 14 TRANSPORT INFORMATION

LAND (DOT) : Not Regulated for Land Transport
LAND (TDG) : Not Regulated for Land Transport
SEA (IMDG) : Not Regulated for Sea Transport according to IMDG-Code
AIR (IATA) : Not Regulated for Air Transport

SECTION 15 REGULATORY INFORMATION

OSHA HAZARD COMMUNICATION STANDARD: When used for its intended purposes, this material is not classified as hazardous in accordance with OSHA 29 CFR 1910.1200.

NATIONAL CHEMICAL INVENTORY LISTING: PICCS, AICS, KECI, TSCA, EINECS

EPCRA: This material contains no extremely hazardous substances.

SARA (311/312) REPORTABLE HAZARD CATEGORIES: None.

SARA (313) TOXIC RELEASE INVENTORY: This material contains no chemicals subject to the supplier notification requirements of the SARA 313 Toxic Release Program.

The Following Ingredients are Cited on the Lists Below:

| CHEMICAL NAME | CAS NUMBER | LIST CITATIONS |
|---------------|------------|----------------|
| Diphenylamine | 122-39-4 | 5 |

| --REGULATORY LISTS SEARCHED-- | | | |
|-------------------------------|------------------|-------------------|-------------|
| 1 = ACGIH ALL | 6 = TSCA 5a2 | 11 = CA P65 REPRO | 16 = MN RTK |
| 2 = ACGIH A1 | 7 = TSCA 5e | 12 = CA RTK | 17 = NJ RTK |
| 3 = ACGIH A2 | 8 = TSCA 6 | 13 = IL RTK | 18 = PA RTK |
| 4 = OSHA Z | 9 = TSCA 12b | 14 = LA RTK | 19 = RI RTK |
| 5 = TSCA 4 | 10 = CA P65 CARC | 15 = MI 293 | |

Code key: CARC=Carcinogen; REPRO=Reproductive

SECTION 16 OTHER INFORMATION

N/D = Not determined, N/A = Not applicable

###

The information and recommendations contained herein are, to the best of Nook Industries' knowledge and belief, accurate and reliable as of the date issued. You can contact Nook Industries to insure that this document is the most current available from Nook Industries. The information and recommendations are offered for the user's consideration and examination. It is the user's responsibility to satisfy itself that the product is suitable for the intended use. If buyer repackages this product, it is the user's responsibility to insure proper health, safety and other necessary information is included with and/or on the container. Appropriate warnings and safe-handling procedures should be provided to handlers and users. Alteration of this document is strictly prohibited. Except to the extent required by law, re-publication or retransmission of this document, in whole or in part, is not permitted.

Product Name: Nook Industries PAG-1 Grease
(Part number NLU-1001)
Revision Date: 23 Sept 2013
Page 1 of 8



MATERIAL SAFETY DATA SHEET

SECTION 1 PRODUCT AND COMPANY IDENTIFICATION

PRODUCT

Product Name: Omniguard
MSDS Number: 778589
Intended Use: Lubricating Grease

COMPANY IDENTIFICATION

Supplier Nook Industries
4950 East 49th Street
Cleveland, Oh 44125
24 Health Emergency: Chemtrec: 800-424-9300 (24 Hours)
MSDS Requests: 800-321-7800
MSDS Internet Address <http://www.nookindustries.com/r/msds>

SECTION 2 HAZARDS IDENTIFICATION

EMERGENCY OVERVIEW

Appearance: Tan
Physical Form: Semi-Solid
Odor: Petroleum

POTENTIAL HEALTH EFFECTS

Eye: Eye irritant. Contact may cause stinging, watering, redness, and swelling.
Skin: Contact may cause mild skin irritation including redness and a burning sensation. Repeated exposure may cause skin dryness or cracking. No information available on skin absorption.
Inhalation (Breathing): No information available on acute toxicity. Inhalation is not an expected route of exposure.
Ingestion (Swallowing): Low degree of toxicity by ingestion.
Signs and Symptoms: Inhalation of oil mists or vapors generated at elevated temperatures may cause respiratory irritation. Accidental ingestion can result in minor irritation of the digestive tract, nausea and diarrhea.
Pre-Existing Medical Conditions: Conditions which may be aggravated by exposure include eye disorders and skin disorders.

See Section 11 for additional Toxicity Information.

SECTION 3 COMPOSITION / INFORMATION ON INGREDIENTS

| COMPONENT | CASRN | CONCENTRATION ¹ |
|---------------------------------|-------------|----------------------------|
| Lubricant Base Oil (Petroleum) | VARIOUS | 50 - 80 |
| Additives | PROPRIETARY | 15 - 40 |
| Calcium Dodecylbenzenesulfonate | 26264-06-2 | 1 - 3 |

¹ All concentrations are percent by weight unless ingredient is a gas. Gas concentrations are in percent by volume.

Product Name: Nook Industries PAG-1 Grease
(Part number NLU-1001)
Revision Date: 23 Sept 2013
Page 2 of 8



SECTION 4 FIRST AID MEASURES

Eye Contact: For direct contact, remove contact lenses if present and easy to do. Immediately hold eyelids apart and flush the affected eye(s) with clean water for at least 15 minutes. Seek immediate medical attention.

Skin Contact: Remove contaminated shoes and clothing and cleanse affected area(s) thoroughly by washing with mild soap and water or a waterless hand cleaner. If irritation or redness develops and persists, seek medical attention. If product is injected into or under the skin, or into any part of the body, regardless of the appearance of the wound or its size, the individual should be evaluated immediately by a physician. (see Note to Physician)

Inhalation (Breathing): If respiratory symptoms develop, move victim away from source of exposure and into fresh air in a position comfortable for breathing. If symptoms persist, seek medical attention.

Ingestion (Swallowing): First aid is not normally required; however, if swallowed and symptoms develop, seek medical attention.

Notes to Physician: High-pressure hydrocarbon injection injuries may produce substantial necrosis of underlying tissue despite an innocuous appearing external wound. These injuries often require extensive emergency surgical debridement and all injuries should be evaluated by a specialist in order to assess the extent of injury. Early surgical treatment within the first few hours may significantly reduce the ultimate extent of injury.

SECTION 5 FIRE-FIGHTING MEASURES

NFPA 704 Hazard Class

| | |
|----------------------|---|
| Health: | 1 |
| Flammability: | 1 |
| Instability: | 0 |

(0-Minimal, 1-Slight, 2-Moderate, 3-Serious, 4-Severe)

Unusual Fire & Explosion Hazards: This material may burn, but will not ignite readily. If container is not properly cooled, it can rupture in the heat of a fire.

Extinguishing Media: Dry chemical, carbon dioxide, foam, or water spray is recommended. Water or foam may cause frothing of materials heated above 212°F / 100°C. Carbon dioxide can displace oxygen. Use caution when applying carbon dioxide in confined spaces. Simultaneous use of foam and water on the same surface is to be avoided as water destroys the foam.

Fire Fighting Instructions: For fires beyond the initial stage, emergency responders in the immediate hazard area should wear protective clothing. When the potential chemical hazard is unknown, in enclosed or confined spaces, a self contained breathing apparatus should be worn. In addition, wear other appropriate protective equipment as conditions warrant (see Section 8).

Isolate immediate hazard area and keep unauthorized personnel out. Stop spill/release if it can be done safely. Move undamaged containers from immediate hazard area if it can be done safely. Water spray may be useful in minimizing or dispersing vapors and to protect personnel. Cool equipment exposed to fire with water, if it can be done safely. Avoid spreading burning liquid with water used for cooling purposes.

Hazardous Combustion Products: Combustion may yield smoke, carbon monoxide, and other products of incomplete combustion.

Oxides of sulfur, nitrogen or phosphorus may also be formed.

See Section 9 for Flammable Properties including Flash Point and Flammable (Explosive) Limits



SECTION 6 ACCIDENTAL RELEASE MEASURES

Personal Precautions: This material may burn, but will not ignite readily. Keep all sources of ignition away from spill/release. Stay upwind and away from spill/release. Avoid direct contact with material. For large spillages, notify persons down wind of the spill/release, isolate immediate hazard area and keep unauthorized personnel out. Wear appropriate protective equipment, including respiratory protection, as conditions warrant (see Section 8). See Sections 2 and 7 for additional information on hazards and precautionary measures.

Environmental Precautions: If spill/release in excess of EPA reportable quantity (see Section 15) is made into the environment, immediately notify the National Response Center (phone number 800-424-8802). Stop spill/release if it can be done safely. Prevent spilled material from entering sewers, storm drains, other unauthorized drainage systems, and natural waterways. Use water sparingly to minimize environmental contamination and reduce disposal requirements. If spill occurs on water notify appropriate authorities and advise shipping of any hazard. Spills into or upon navigable waters, the contiguous zone, or adjoining shorelines that cause a sheen or discoloration on the surface of the water, may require notification of the National Response Center (phone number 800-424-8802).

Methods for Containment and Clean-Up: Notify relevant authorities in accordance with all applicable regulations. Immediate cleanup of any spill is recommended. Dike far ahead of spill for later recovery or disposal. Absorb spill with inert material such as sand or vermiculite, and place in suitable container for disposal. If spilled on water remove with appropriate methods (e.g. skimming, booms or absorbents). In case of soil contamination, remove contaminated soil for remediation or disposal, in accordance with local regulations.

SECTION 7 HANDLING AND STORAGE

Precautions for safe handling: Keep away from flames and hot surfaces. Wear eye/face protection. Wash thoroughly after handling.

Use good personal hygiene practices and wear appropriate personal protective equipment.

High pressure injection of hydrocarbon fuels, hydraulic oils or greases under the skin may have serious consequences even though no symptoms or injury may be apparent. This can happen accidentally when using high pressure equipment such as high pressure grease guns, fuel injection apparatus or from pinhole leaks in tubing of high pressure hydraulic oil equipment.

Do not enter confined spaces such as tanks or pits without following proper entry procedures such as ASTM D-4276 and 29CFR 1910.146. Do not wear contaminated clothing or shoes.

Conditions for safe storage: Keep container(s) tightly closed and properly labeled. Use and store this material in cool, dry, well-ventilated area away from heat and all sources of ignition. Store only in approved containers. Keep away from any incompatible material (see Section 10). Protect container(s) against physical damage.

"Empty" containers retain residue and may be dangerous. Do not pressurize, cut, weld, braze, solder, drill, grind, or expose such containers to heat, flame, sparks, or other sources of ignition. They may explode and cause injury or death. "Empty" drums should be completely drained, properly bunged, and promptly shipped to the supplier or a drum reconditioner. All containers should be disposed of in an environmentally safe manner and in accordance with governmental regulations. Before working on or in tanks which contain or have contained this material, refer to OSHA regulations, ANSI Z49.1, and other references pertaining to cleaning, repairing, welding, or other contemplated operations.

Product Name: Nook Industries PAG-1 Grease
(Part number NLU-1001)
Revision Date: 23 Sept 2013
Page 4 of 8



SECTION 8 EXPOSURE CONTROLS / PERSONAL PROTECTION

| COMPONENT | US-ACGIH | OSHA | OTHER |
|-----------------------------------|--|---|-------|
| Lubricant Base Oil (Petroleum) | TWA: 5mg/m ³ STEL: 10 mg/m ³ as Oil Mist, if generated | TWA: 5 mg/m ³ as Oil Mist, if generated | --- |

NOTE: State, local or other agencies or advisory groups may have established more stringent limits. Consult an industrial hygienist or similar professional, or your local agencies, for further information.

Engineering controls: If current ventilation practices are not adequate to maintain airborne concentrations below the established exposure limits, additional engineering controls may be required.

Eye/Face Protection: The use of eye protection that meets or exceeds ANSI Z.87.1 is recommended to protect against potential eye contact, irritation, or injury. Depending on conditions of use, a face shield may be necessary.

Skin/Hand Protection: The use of gloves impervious to the specific material handled is advised to prevent skin contact. Users should check with manufacturers to confirm the breakthrough performance of their products. Suggested protective materials: Nitrile

Respiratory Protection: Respiratory protection is not normally required under intended conditions of use. Emergencies or conditions that could result in significant airborne exposures may require the use of NIOSH approved respiratory protection. An industrial hygienist or other appropriate health and safety professional should be consulted for specific guidance under these situations.

Other Protective Equipment: Eye wash and quick-drench shower facilities should be available in the work area. Thoroughly clean shoes and wash contaminated clothing before reuse.

Suggestions provided in this section for exposure control and specific types of protective equipment are based on readily available information. Users should consult with the specific manufacturer to confirm the performance of their protective equipment. Specific situations may require consultation with industrial hygiene, safety, or engineering professionals.

SECTION 9 PHYSICAL AND CHEMICAL PROPERTIES

NOTE: Unless otherwise stated, values are determined at 20°C (68°F) and 760 mm Hg (1 atm). Data represent typical values and are not intended to be specifications.

| | |
|--------------------------------------|------------------------|
| Appearance: | Tan |
| Physical Form: | Semi-Solid |
| Odor: | Petroleum |
| Odor Threshold: | No data |
| pH: | Not applicable |
| Vapor Pressure: | <0.1 mm Hg |
| Vapor Density (air=1): | > 5 |
| Initial Boiling Point/Range: | No data |
| Melting/Freezing Point: | No data |
| Solubility in Water: | Insoluble |
| Solubility in Other Solvents: | Soluble |
| Partition Coefficient | |
| (n-octanol/water) (Kow): | No data |
| Specific Gravity (water=1): | 0.9943 @ 60°F (15.6°C) |
| Bulk Density: | 8.29 lbs/gal |

Product Name: Nook Industries PAG-1 Grease
(Part number NLU-1001)
Revision Date: 23 Sept 2013
Page 5 of 8



Evaporation Rate (nBuAc=1): <1
Flash Point: 464°F / 240°C
Test Method: Cleveland Open Cup (COC), ASTM D92
Lower Explosive Limits (vol % in air): No data
Upper Explosive Limits (vol % in air): No data
Auto-ignition Temperature: No data

SECTION 10 STABILITY AND REACTIVITY

Stability: Stable under normal ambient and anticipated conditions of use.

Conditions to Avoid: Extended exposure to high temperatures can cause decomposition. Avoid all possible sources of ignition.

Materials to Avoid (Incompatible Materials): Avoid contact with strong oxidizing agents and strong reducing agents.

Hazardous Decomposition Products: Not anticipated under normal conditions of use.

Hazardous Polymerization: Not known to occur.

SECTION 11 TOXICOLOGICAL INFORMATION

CHRONIC TOXICITY:

Lubricant Base Oil (Petroleum)

Carcinogenicity: The petroleum base oils contained in this product have been highly refined by a variety of processes including severe hydrocracking/hydroprocessing to reduce aromatics and improve performance characteristics. All of the oils meet the IP-346 criteria of less than 3 percent PAH's and are not considered carcinogens by NTP, IARC, or OSHA.

ACUTE TOXICITY:

| COMPONENT | ORAL LD50 | DERMAL LD50 | INHALATION LC50 |
|---------------------------------|-------------|-------------|-----------------|
| Lubricant Base Oil (Petroleum) | > 5 g/kg | > 2 g/kg | > 5 mg/L |
| Calcium Dodecylbenzenesulfonate | 1,300 mg/kg | No data | No data |

SECTION 12 ECOLOGICAL INFORMATION

Ecotoxicity: Experimental studies show that acute aquatic toxicity values are greater than 1000 mg/l. These values are consistent with the predicted aquatic toxicity of these substances based on their hydrocarbon compositions. However, there is insufficient information available on the toxicity of the thickening agents used in greases. Should therefore be regarded as capable of causing long term adverse effects in the aquatic environment.

Mobility: Volatilization to air is not expected to be a significant fate process due to the low vapor pressure of this material.

Components may behave differently in the aquatic environment with soaps dispersing and dissolving to some extent in water while the hydrocarbons will float on the surface due to their low water solubility. The hydrocarbon portion would be expected to show low mobility in soil and water. The major environmental fate would be expected to be biodegradation.

Product Name: Nook Industries PAG-1 Grease
(Part number NLU-1001)
Revision Date: 23 Sept 2013
Page 6 of 8



Persistence and degradability: The base oil constituents of greases are expected to be inherently, but not readily biodegradable.

Some of the thickening agents may be readily biodegradable.

Bioaccumulation Potential: Log Kow values measured for the hydrocarbon components of this material range from 4 to over 6, and therefore regarded as having the potential to bioaccumulate. In practice, metabolic processes may reduce bioconcentration.

SECTION 13 DISPOSAL CONSIDERATIONS

The generator of a waste is always responsible for making proper hazardous waste determinations and needs to consider state and local requirements in addition to federal regulations.

This material, if discarded as produced, would not be a federally regulated RCRA "listed" hazardous waste and is not believed to exhibit characteristics of hazardous waste. See Sections 7 and 8 for information on handling, storage and personal protection and Section 9 for physical/chemical properties. It is possible that the material as produced contains constituents which are not required to be listed in the MSDS but could affect the hazardous waste determination. Additionally, use which results in chemical or physical change of this material could subject it to regulation as a hazardous waste.

This material under most intended uses would become "Used Oil" due to contamination by physical or chemical impurities. Whenever possible, Recycle Used Oil in accordance with applicable federal and state or local regulations. Container contents should be completely used and containers should be emptied prior to discard.

SECTION 14 TRANSPORTATION INFORMATION

U.S. DEPARTMENT OF TRANSPORTATION (DOT)

Shipping Description: Not regulated

NOTE: If shipped by land in a packaging having a capacity of 3,500 gallons or more, the provisions of 49 CFR, Part 130 apply. (Contains oil)

INTERNATIONAL MARITIME DANGEROUS GOODS (IMDG)

Shipping Description: Not regulated

NOTE: U.S. DOT compliance requirements may apply. See 49 CFR 171.22, 23 & 25.

INTERNATIONAL CIVIL AVIATION ORG.

INTERNATIONAL AIR TRANSPORT ASSOC. (ICAO/IATA)

UN/ID #: Not regulated

NOTE: U.S. DOT compliance requirements may apply. See 49 CFR 171.22, 23 & 24.

| | LTD. QTY | PASSENGER AIRCRAFT | CARGO AIRCRAFT ONLY |
|---|----------|--------------------|---------------------|
| Packaging Instruction #: | --- | --- | --- |
| Max. Net Qty. Per Package: | --- | --- | --- |
| Packaging Instruction # after 12/31/2010: | | | |

Product Name: Nook Industries PAG-1 Grease
(Part number NLU-1001)
Revision Date: 23 Sept 2013
Page 7 of 8



SECTION 15 REGULATORY INFORMATION

CERCLA/SARA

Section 302 Extremely Hazardous Substances and TPQs (in pounds):

This material does not contain any chemicals subject to the reporting requirements of SARA 302 and 40 CFR 372.

CERCLA/SARA

Section 311/312 (Title III Hazard Categories)

Acute Health: Yes
Chronic Health: No
Fire Hazard: No
Pressure Hazard: No
Reactive Hazard: No

| COMPONENT | RQ |
|---------------------------------|---------|
| Calcium Dodecylbenzenesulfonate | 1000 lb |

CALIFORNIA PROPOSITION 65

WARNING: This material may contain detectable quantities of the following chemicals, known to the State of California to cause cancer, birth defects or other reproductive harm, and which may be subject to the requirements of California Proposition 65 (CA Health & Safety Code Section 25249.5):

| COMPONENT | TYPE OF TOXICITY |
|-----------------|------------------|
| 1-Naphthylamine | Cancer |
| 2-Naphthylamine | Cancer |

CANADIAN REGULATIONS

This product has been classified in accordance with the hazard criteria of the Controlled Products Regulations (CPR) and the MSDS contains all the information required by the Regulations.

WHMIS Hazard Class D2B

NATIONAL CHEMICAL INVENTORIES:

All components are either listed on the USTSCA Inventory, or are not regulated under TSCA.

All components are either on the DSL, or are exempt from DSL listing requirements.

U.S. Export Control Classification Number: EAR99

Product Name: Nook Industries PAG-1 Grease
(Part number NLU-1001)
Revision Date: 23 Sept 2013
Page 8 of 8



SECTION 16 OTHER INFORMATION

| | |
|-----------------------------|--------------|
| Date of Issue: | 06-Aug-2010 |
| Status: | FINAL |
| Previous Issue Date: | 27-Aug-2007 |
| MSDS Number: | 778589 |

Guide to Abbreviations:

ACGIH = American Conference of Governmental Industrial Hygienists

CASRN = Chemical Abstracts Service Registry Number

CEILING = Ceiling Limit (15 minutes)

CERCLA = The Comprehensive Environmental Response, Compensation, and Liability Act

EPA = Environmental Protection Agency

IARC = International Agency for Research on Cancer

LEL = Lower Explosive Limit

NE = Not Established

NFPA = National Fire Protection Association

NTP = National Toxicology Program

OSHA = Occupational Safety and Health Administration

PEL = Permissible Exposure Limit (OSHA)

SARA = Superfund Amendments and Reauthorization Act

STEL = Short Term Exposure Limit (15 minutes)

TLV = Threshold Limit Value (ACGIH)

TWA = Time Weighted Average (8 hours)

UEL = Upper Explosive Limit

WHMIS = Worker Hazardous Materials Information System (Canada)



MATERIAL SAFETY DATA SHEET

76 Unax AW 32, 46, 68

1. PRODUCT AND COMPANY IDENTIFICATION

Product Name: 76 Unax AW 32, 46, 68
Product Code: 4641032000, 4642046000, 4643068000
Synonyms: 76 Unax AW 32
 76 Unax AW 46
 76 Unax AW 68
Intended Use: Industrial oil
Chemical Family: Petroleum hydrocarbon
Responsible Party: 76 Lubricants
 A Division of ConocoPhillips
 600 N. Dairy Ashford
 Houston, TX 77079-1175
For Additional MSDSs 800-762-0942
Technical Information: 800-435-7761

The intended use of this product is indicated above. If any additional use is known, please contact us at the Technical Information number listed.

EMERGENCY OVERVIEW

24 Hour Emergency Telephone Numbers:

Spill, Leak, Fire or Accident California Poison Control System: (800) 356-3129
 Call CHEMTREC
 North America: (800)424-9300
 Others: (703)527-3887 (collect)

Health Hazards/Precautionary Measures: Avoid contact with eyes, skin and clothing. Wash thoroughly after handling.

Physical Hazards/Precautionary Measures: Keep away from all sources of ignition.

Appearance: Clear and bright
Physical form: Liquid
Odor: Mild petroleum

NFPA Hazard Class:

Health: 1 (Slight)
 Flammability: 1 (Slight)
 Reactivity: 0 (Least)

HMIS Hazard Class

Health: 1 (Slight)
 Flammability: 1 (Slight)
 Physical Hazard: 0 (Least)

2. COMPOSITION/INFORMATION ON INGREDIENTS

| <u>HAZARDOUS COMPONENTS</u> | <u>% WEIGHT</u> | <u>EXPOSURE GUIDELINE</u> | | |
|-----------------------------------|-----------------|---------------------------|---------------|-------------|
| | | <u>Limits</u> | <u>Agency</u> | <u>Type</u> |
| Zinc Compound CAS# Proprietary | <1 | Not Established | | |

| <u>OTHER COMPONENTS</u> | <u>% WEIGHT</u> | <u>EXPOSURE GUIDELINE</u> | | |
|--|-----------------|-------------------------------|---------------|-------------|
| | | <u>Limits</u> | <u>Agency</u> | <u>Type</u> |
| Lubricant Base Oil (Petroleum) CAS# Various | >99 | (See: Oil Mist, If Generated) | | |
| Additives CAS# Proprietary | <1 | Not Established | | |

| <u>REFERENCE</u> | <u>EXPOSURE GUIDELINE</u> | | |
|-------------------------------------|---------------------------|---------------|-------------|
| | <u>Limits</u> | <u>Agency</u> | <u>Type</u> |
| Oil Mist, If Generated CAS# None | 5 mg/m3 | ACGIH | TWA |
| | 10 mg/m3 | ACGIH | STEL |
| | 5 mg/m3 | OSHA | TWA |
| | 2500 mg/m3 | NIOSH | IDLH |
| | 5 mg/m3 | NOHSC | TWA |

The base oil for this product can be a mixture of any of the following highly refined petroleum streams:
CAS 64741-88-4; CAS 64741-89-5; CAS 64741-96-4; CAS 64741-97-5; CAS 64742-01-4; CAS 64742-52-5; CAS 64742-53-6; CAS 64742-54-7; CAS 64742-55-8; CAS 64742-56-9; CAS 64742-57-0; CAS 64742-62-7; CAS 64742-63-8; CAS 64742-65-0; CAS 72623-85-9; CAS 72623-86-0; CAS 72623-87-1

Note: State, local or other agencies or advisory groups may have established more stringent limits. Consult an industrial hygienist or similar professional, or your local agencies, for further information.

1%=10,000 PPM.

All components are listed on the TSCA inventory.

3. HAZARDS IDENTIFICATION

Potential Health Effects:

Eye: Contact may cause mild eye irritation including stinging, watering, and redness.

Skin: Contact may cause mild skin irritation including redness, and a burning sensation. Prolonged or repeated contact can worsen irritation by causing drying and cracking of the skin leading to dermatitis (inflammation). No harmful effects from skin absorption are expected.

Inhalation (Breathing): No information available. Studies by other exposure routes suggest a low degree of toxicity by inhalation.

Ingestion (Swallowing): No harmful effects expected from ingestion.

Signs and Symptoms: Effects of overexposure may include irritation of the nose and throat, irritation of the digestive tract, nausea and diarrhea.

Cancer: Inadequate evidence available to evaluate the cancer hazard of this material. See Section 11 for carcinogenicity information of individual components, if any.

Target Organs: No data available for this material.

Developmental: No data available for this material.

Pre-Existing Medical Conditions: Conditions aggravated by exposure may include skin disorders.

4. FIRST AID MEASURES

Eye: If irritation or redness develops, move victim away from exposure and into fresh air. Flush eyes with clean water. If symptoms persist, seek medical attention.

Skin: Wipe material from skin and remove contaminated shoes and clothing. Cleanse affected area(s) thoroughly by washing with mild soap and water and, if necessary, a waterless skin cleanser. If irritation or redness develops and persists, seek medical attention.

Inhalation (Breathing): If respiratory symptoms develop, move victim away from source of exposure and into fresh air. If symptoms persist, seek medical attention. If victim is not breathing, clear airway and immediately begin artificial respiration. If breathing difficulties develop, oxygen should be administered by qualified personnel. Seek immediate medical attention.

Ingestion (Swallowing): First aid is not normally required; however, if swallowed and symptoms develop, seek medical attention.

Note To Physicians: High-pressure hydrocarbon injection injuries may produce substantial necrosis of underlying tissue despite an innocuous appearing external wound. Often these injuries require extensive emergency surgical debridement and all injuries should be evaluated by a specialist in order to assess the extent of injury.

5. FIRE FIGHTING MEASURES

Flammable Properties:

- Flash Point: >384°F/>196°C (COC)
- OSHA Flammability Class: Not applicable
- LEL/UEL%: No Data
- Autoignition Temperature: No Data

Unusual Fire & Explosion Hazards: This material may burn, but will not ignite readily. If container is not properly cooled, it can rupture in the heat of a fire.

Extinguishing Media: Dry chemical, carbon dioxide, foam, or water spray is recommended. Water or foam may cause frothing of materials heated above 212°F. Carbon dioxide can displace oxygen. Use caution when applying carbon dioxide in confined spaces.

Fire Fighting Instructions: For fires beyond the incipient stage, emergency responders in the immediate hazard area should wear bunker gear. When the potential chemical hazard is unknown, in enclosed or confined spaces, or when explicitly required by DOT, a self contained breathing apparatus should be worn. In addition, wear other appropriate protective equipment as conditions warrant (see Section 8).

Isolate immediate hazard area, keep unauthorized personnel out. Stop spill/release if it can be done with minimal risk. Move undamaged containers from immediate hazard area if it can be done with minimal risk.

Water spray may be useful in minimizing or dispersing vapors and to protect personnel. Cool equipment exposed to fire with water, if it can be done with minimal risk. Avoid spreading burning liquid with water used for cooling purposes.

6. ACCIDENTAL RELEASE MEASURES

This material may burn, but will not ignite readily. Keep all sources of ignition away from spill/release. Stay upwind and away from spill/release. Notify persons down wind of the spill/release, isolate immediate hazard area and keep unauthorized personnel out. Stop spill/release if it can be done with minimal risk. Wear appropriate protective equipment including respiratory protection as conditions warrant (see Section 8).

Prevent spilled material from entering sewers, storm drains, other unauthorized drainage systems, and natural waterways. Dike far ahead of spill for later recovery or disposal. Spilled material may be absorbed into an appropriate absorbent material.

Notify fire authorities and appropriate federal, state, and local agencies. Immediate cleanup of any spill is recommended. If spill of any amount is made into or upon navigable waters, the contiguous zone, or adjoining shorelines, notify the National Response Center (phone number 800-424-8802).

7. HANDLING AND STORAGE

Handling: Do not enter confined spaces such as tanks or pits without following proper entry procedures such as ASTM D-4276 and 29CFR 1910.146. The use of appropriate respiratory protection is advised when concentrations exceed any established exposure limits (see Sections 2 and 8).

Do not wear contaminated clothing or shoes. Use good personal hygiene practices.

High pressure injection of hydrocarbon fuels, hydraulic oils or greases under the skin may have serious consequences even though no symptoms or injury may be apparent. This can happen accidentally when using high pressure equipment such as high pressure grease guns, fuel injection apparatus or from pinhole leaks in tubing of high pressure hydraulic oil equipment.

"Empty" containers retain residue and may be dangerous. Do not pressurize, cut, weld, braze, solder, drill, grind, or expose such containers to heat, flame, sparks, or other sources of ignition. They may explode and cause injury or death. "Empty" drums should be completely drained, properly bunged, and promptly shipped to the supplier or a drum reconditioner. All containers should be disposed of in an environmentally safe manner and in accordance with governmental regulations.

Before working on or in tanks which contain or have contained this material, refer to OSHA regulations, ANSI Z49.1 and other references pertaining to cleaning, repairing, welding, or other contemplated operations.

Storage: Keep container(s) tightly closed. Use and store this material in cool, dry, well-ventilated areas away from heat and all sources of ignition. Store only in approved containers. Keep away from any incompatible material (see Section 10). Protect container(s) against physical damage.

8. EXPOSURE CONTROLS/PERSONAL PROTECTION

Engineering controls: If current ventilation practices are not adequate to maintain airborne concentrations below the established exposure limits (see Section 2), additional engineering controls may be required.

Personal Protective Equipment (PPE):

Respiratory: A NIOSH certified air purifying respirator with a Type 95 (R or P) particulate filter may be used under conditions where airborne concentrations are expected to exceed exposure limits (see Section 2).

Protection provided by air purifying respirators is limited (see manufacturer's respirator selection guide). Use a NIOSH approved self-contained breathing apparatus (SCBA) or equivalent operated in a pressure demand or other positive pressure mode if there is potential for an uncontrolled release, exposure levels are not known, or any other circumstances where air purifying respirators may not provide adequate protection. A respiratory protection program that meets OSHA's 29 CFR 1910.134 and ANSI Z88.2 requirements must be followed whenever workplace conditions warrant a respirator's use.

Skin: The use of gloves impervious to the specific material handled is advised to prevent skin contact and possible irritation (see manufacturers literature for information on permeability).

Eye/Face: Approved eye protection to safeguard against potential eye contact, irritation, or injury is recommended. Depending on conditions of use, a face shield may be necessary.

Other Protective Equipment: A source of clean water should be available in the work area for flushing eyes and skin. Impervious clothing should be worn as needed.

Suggestions for the use of specific protective materials are based on readily available published data. Users should check with specific manufacturers to confirm the performance of their products.

9. PHYSICAL AND CHEMICAL PROPERTIES

Note: Unless otherwise stated, values are determined at 20°C (68°F) and 760 mm Hg (1 atm).

Appearance: Clear and bright

Physical State: Liquid

Odor: Mild petroleum

pH: Not applicable

Vapor Pressure (mm Hg): <1

Vapor Density (air=1): >1

Boiling Point/Range: No Data

Freezing/Melting Point: <-27°F / <-33°C

Solubility in Water: Negligible

Specific Gravity: 0.855-0.871

Percent Volatile: Negligible

Evaporation Rate (nBuAc=1): Negligible

Viscosity: 22-68 cSt @ 40°C / 4.3-8.7 cSt @ 100°C

Bulk Density: 7.13-7.26 lb/gal

Flash Point: >384°F / >196°C (COC)

Flammable/Explosive Limits (%): No Data

10. STABILITY AND REACTIVITY

Stability: Stable under normal ambient and anticipated storage and handling conditions of temperature and pressure.

Conditions To Avoid: Extended exposure to high temperatures can cause decomposition.

Materials to Avoid (Incompatible Materials): Avoid contact with strong oxidizing agents.

Hazardous Decomposition Products: Combustion can yield carbon, nitrogen, sulfur, phosphorus, and zinc oxides.

Hazardous Polymerization: Will not occur.

11. TOXICOLOGICAL INFORMATION

Lubricant Base Oil (Petroleum) (CAS# Various)

Carcinogenicity: The petroleum base oils contained in this product have been highly refined by a variety of processes including solvent extraction, hydrotreating, and dewaxing to remove aromatics and improve performance characteristics. None of the oils used are listed as a carcinogen by NTP, IARC, or OSHA.

12. ECOLOGICAL INFORMATION

Not evaluated at this time

(MSDS: 722330)

Page 6 of 7

13. DISPOSAL CONSIDERATIONS

This material under most intended uses would become used oil due to contamination by physical or chemical impurities. RECYCLE ALL USED OIL. While being recycled, used oil is regulated by 40 CFR 279. Use resulting in chemical or physical change or contamination may also subject it to regulation as hazardous waste. Under federal regulations, used oil is a solid waste managed under 40 CFR 279. However, in California, used oil is managed as hazardous waste until tested to show it is not hazardous. Consult state and local regulations regarding the proper handling of used oil. In the case of used oil, the intent to discard it may cause the used oil to be regulated as hazardous waste.

Contents should be completely used and containers emptied prior to discard. Rinsate may be considered a RCRA hazardous waste and must be disposed of with care and in compliance with federal, state and local regulations. Large empty containers, such as drums, should be returned to the distributor or a drum reconditioner. To assure proper disposal of small empty containers, consult with state and local regulations and disposal authorities.

14. TRANSPORT INFORMATION

DOT Shipping Description: Not classified as hazardous

15. REGULATORY INFORMATION

EPA SARA 311/312 (Title III Hazard Categories):

Acute Health: No
Chronic Health: No
Fire Hazard: No
Pressure Hazard: No
Reactive Hazard: No

SARA 313 and 40 CFR 372:

This material contains the following chemicals subject to the reporting requirements of SARA 313 and 40 CFR 372:

| Component | CAS Number | Weight % |
|------------------|-------------------|-----------------|
| Zinc Compound | Proprietary | <1 |

California Proposition 65:

Warning: This material contains the following chemicals which are known to the State of California to cause cancer, birth defects or other reproductive harm, and are subject to the requirements of California Proposition 65 (CA Health & Safety Code Section 25249.5):

--None Known--

Carcinogen Identification:

This material has not been identified as a carcinogen by NTP, IARC, or OSHA. See Section 11 for carcinogenicity information of individual components, if any.

EPA (CERCLA) Reportable Quantity:

--None--

Canada - Domestic Substances List: Listed

WHMIS Class:

Not regulated

This product has been classified in accordance with the hazard criteria of the Controlled Products Regulations (CPR) and the MSDS contains all the information required by the CPR.

16. OTHER INFORMATION

Issue Date: 02/06/03

(MSDS: 722330)

Page 7 of 7

Previous Issue Date: 01/01/02
Product Code: 4641032000, 4642046000, 4643068000
Revised Sections: New Format
Previous Product Code: 4641032000
MSDS Number: 722330
Status: Final

Disclaimer of Expressed and Implied Warranties:

The information presented in this Material Safety Data Sheet is based on data believed to be accurate as of the date this Material Safety Data Sheet was prepared. **HOWEVER, NO WARRANTY OF MERCHANTABILITY, FITNESS FOR ANY PARTICULAR PURPOSE, OR ANY OTHER WARRANTY IS EXPRESSED OR IS TO BE IMPLIED REGARDING THE ACCURACY OR COMPLETENESS OF THE INFORMATION PROVIDED ABOVE, THE RESULTS TO BE OBTAINED FROM THE USE OF THIS INFORMATION OR THE PRODUCT, THE SAFETY OF THIS PRODUCT, OR THE HAZARDS RELATED TO ITS USE.** No responsibility is assumed for any damage or injury resulting from abnormal use or from any failure to adhere to recommended practices. The information provided above, and the product, are furnished on the condition that the person receiving them shall make their own determination as to the suitability of the product for their particular purpose and on the condition that they assume the risk of their use. In addition, no authorization is given nor implied to practice any patented invention without a license.

 **CLIMAX**
Family of Brands

 **BORTECH**

 **CALDER**
TESTERS

H&S TOOL