

CE

SPEED FACER

ODF60 FLANSCHENDREHMASCHINE

BETRIEBSHANDBUCH

ORIGINALANLEITUNG



H&S TOOL
A CLIMAX COMPANY

P/N 87523
März 2017
Revision 1

CLIMAX
Family of Brands

BORTECH

CALDER
TESTERS **H&S TOOL**

©2017 CLIMAX Portable Machining and Welding Systems oder deren Tochterunternehmen.
Alle Rechte vorbehalten.

Mit Ausnahme der ausdrücklich hier folgen genannten Teile, darf ohne die vorherige schriftliche Genehmigung durch Climax kein Teil dieses Handbuchs reproduziert, kopiert, übertragen, verbreitet, heruntergeladen oder auf einem beliebigen Speichermedium gespeichert werden. Hiermit erteilt Climax die Genehmigung zum Herunterladen einer einzigen Kopie dieses Handbuchs und jeder folgenden überarbeiteten Version auf ein elektronisches Speichermedium, damit das Handbuch gelesen und eine Kopie davon ausgedruckt werden kann. Bedingung ist, dass dieses Handbuch oder jede seiner revidierten Ausgaben, die über diese elektronische oder ausgedruckte Form erstellt werden, den vollständigen Text und die Copyright-Kennzeichnung enthalten und damit eine ungehenmigte Verbreitung dieses Handbuchs und seiner überarbeiteten Ausgaben verhindert wird, weil dies verboten ist.

Bei Climax Portable Machining and Welding Systems legen wir wert auf Ihre Meinung.

Für Kommentare oder Fragen zu diesem Handbuch oder der Dokumentation von Climax schicken Sie bitte eine Email an:

documentation@cpmt.com.

Für Kommentare oder Fragen zu Produkten oder Dienstleistungen von Climax, rufen Sie uns bitte an oder schreiben Sie an info@cpmt.com. Damit wir Ihnen einen schnellen und genauen Service bieten können, geben Sie uns bitte die folgenden Informationen zu Ihrem Unternehmen:

- Ihr Name
- Lieferanschrift
- Telefonnummer
- Maschinenmodell
- Seriennummer (falls zutreffend)
- Erwerbsdatum

Climax Welt-Firmenzentrale

Climax Portable Machining and Welding Systems
2712 South Second Street Newberg, Oregon 97132 USA
Telefonnummer (weltweit): (503) 538-2815
Gebührenfrei (Nordamerika): 1-800-333-8311
Fax: 503.538.7600
E-mail: info@cpmt.com

Climax UK-Firmenzentrale

Climax Portable Machine Tools Ltd
Unit 10 Heather Close
Lyme Green Business Park
Macclesfield, Cheshire SK11 0LR, UK
Telefon: +44 (0) 161 406 1720
E-mail: info@cpmt.com

Climax Europa-Firmenzentrale

Climax GmbH
Am Langen Graben 8
52353 Düren, Deutschland
Telefon: +49 (0) 2421-9177-12
E-mail: info@cpmt.de

CLIMAX STANDORTE WELTWEIT

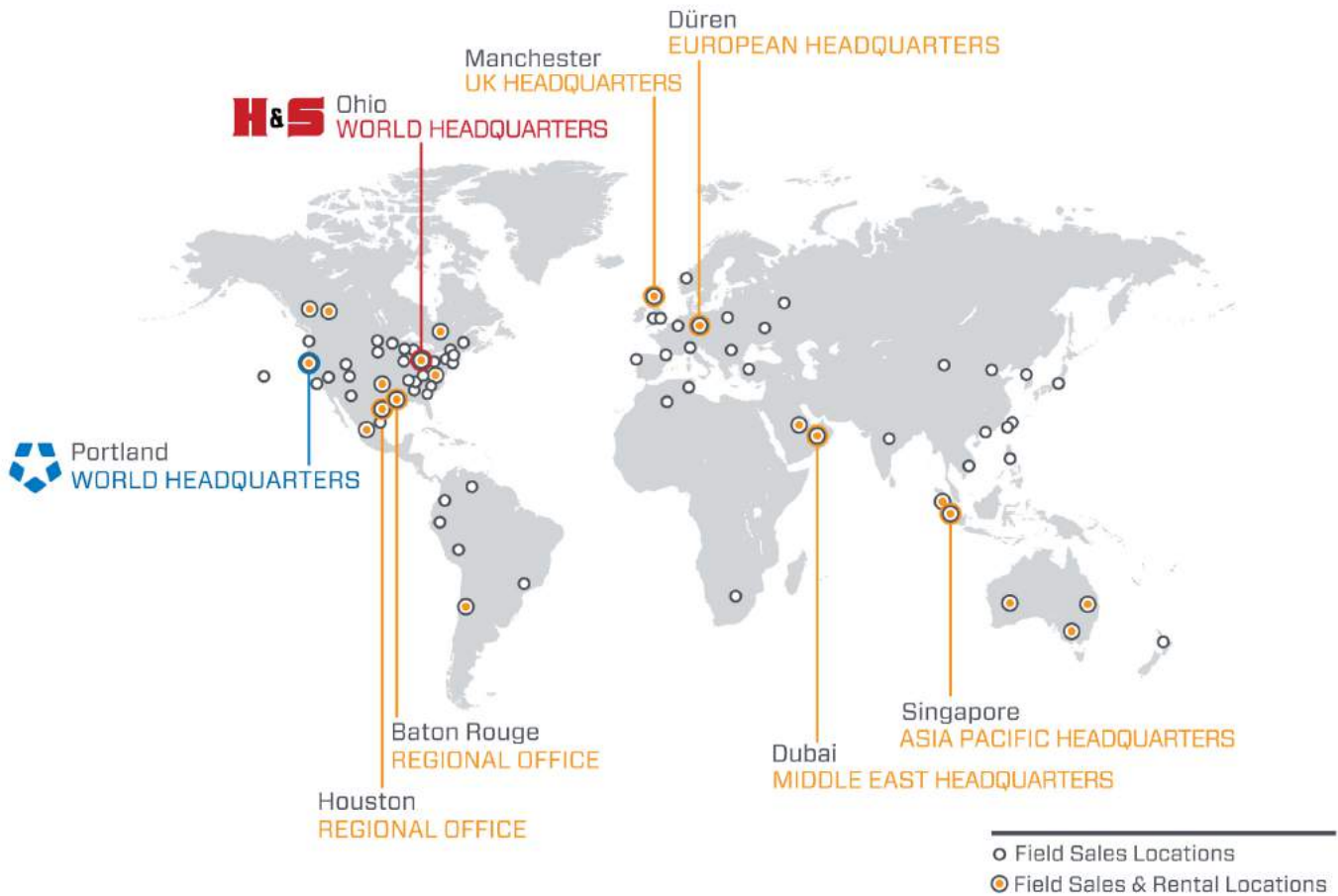

CE-DOKUMENTATION

Name of manufacturer or supplier

H&S Tool

Full postal address including country of origin

715 Weber Drive
Wadsworth, OH 44281
USA

Description of product

ODF60 Speedfacer Flange Facer

Name, type or model, batch or serial number

Model ODF60

Serial Number Range OD60071601 to
OD60122001

Pneumatic Powered

Standards used, including number, title, issue date and other relative documents

EN 953, EN 3744, EN 4413, EN 4414, EN 11201, EN 12100, EN 13128, EN 13732, EN 13849, EN 13857

Name of Responsible Person within the EU Tom Cunningham

Full postal address if different from manufacturers

Climax GmbH
Am Langen Graben 8
52353 Duren, Germany

Declaration

I declare that as the Manufacturer, the above information in relation to the supply / manufacture of this product, is in conformity with the stated standards and other related documents following the provisions of the above Directives and their amendments.

Signature of Manufacturer: 

Position Held: *Director of Engineering; R&D*

Date: *7/20/2016*



BEGRENZTE GARANTIE

Climax Portable Machine Tools, Inc. (im Weiteren Verlauf auch „CLIMAX“) garantiert, dass alle neuen Maschinen ohne Material- oder Herstellungsfehler ausgeliefert werden. Diese Garantie gilt für jeden Erwerber ein Jahr lang nach der Lieferung. Sollte der ursprüngliche Erwerber während dieser Garantiezeit irgendeinen Material- oder Herstellungsfehler entdecken, muss dieser ursprüngliche Erwerber den Werksvertreter informieren und die gesamte Maschine auf eigene Kosten zurück zum Werk schicken. CLIMAX steht es frei, die defekte Maschine kostenfrei zu reparieren oder auszutauschen und wird die Maschine dann auf eigene Kosten zurücksenden.

CLIMAX garantiert, dass alle Teile ohne Material- oder Herstellungsfehler sind und dass die Arbeiten daran fachgerecht ausgeführt worden sind. Diese Garantie wird dem Erwerber für gelieferte Teile oder Arbeiten für eine Dauer von 90 Tagen nach der Auslieferung gewährt. Sollte der Erwerber während dieser Garantiezeit irgendeinen Material- oder Herstellungsfehler entdecken, muss dieser ursprüngliche Erwerber den Werksvertreter informieren und das Teil oder die reparierte Maschine auf eigene Kosten zurück zum Werk schicken. CLIMAX steht es frei, auf eigene Kosten das defekte Teil zu ersetzen und/oder alle Defekte bei der Bearbeitung der Maschine zu beheben und wird die Maschine dann auf eigene Kosten zurücksenden.

Diese Garantien gelten nicht für die folgenden Fälle:

- Beschädigung nach dem Tag des Versandes, die nicht auf Material- und Herstellungsfehler zurückzuführen sind.
- Schäden, die durch unsachgemäße bzw. unzureichende Wartung entstanden sind.
- Schäden, die durch nicht genehmigte Veränderungen oder Reparaturen an der Maschine entstanden sind.
- Schäden, die durch nicht bestimmungsgemäßen Einsatz der Maschine entstanden sind.
- Schäden, die durch Überlastung der Maschine entstanden sind.

Alle anderen genannten oder erwähnten Garantien, einschließlich unbeschränkter Vertriebsgarantien und Eignung für bestimmte Zwecke werden hiermit abgelehnt und ausgeschlossen.

Geschäftsbedingungen

Lesen Sie die Geschäftsbedingungen auf der Rückseite Ihrer Rechnung genau durch. Diese Bedingungen regeln und beschränken Ihre Rechte in Bezug auf die von CLIMAX gelieferten Güter.

Verwendung dieses Handbuchs

CLIMAX stellt den Inhalt dieses Handbuchs in Gutem Glauben als eine Richtlinie für den Bediener zur Verfügung. CLIMAX kann nicht dafür garantieren, dass die in diesem Handbuch enthaltenen Informationen für andere Anwendungen gelten, als die, die in diesem Handbuch beschrieben sind. Produktspezifikationen können ohne Ankündigung geändert werden.

INHALTSVERZEICHNIS

KAPITEL/ABSCHNITT	SEITE
1 EINLEITUNG	1
1.1 VERWENDUNG DIESES HANDBUCHS	1
1.2 SICHERHEITSHINWEISE	1
1.3 ALLGEMEINE SICHERHEITSMASSNAHMEN	2
1.4 MASCHINEN-SPEZIFISCHE SICHERHEITSMASSNAHMEN	3
1.5 RISIKOBEWERTUNG UND -REDUZIERUNG	4
1.6 CHECKLISTE DER RISIKOBEWERTUNG	5
1.7 KENNZEICHNUNG	6
1.7.1 Kennzeichnungsart	6
1.7.2 Platzierung der Kennzeichnung	7
2 ÜBERSICHT	9
2.1 EIGENSCHAFTEN UND KOMPONENTEN	9
2.2 STEUERUNG	10
2.3 ABMESSUNGEN	10
2.4 SPEZIFIKATIONEN	12
2.5 ERFORDERLICHE TEILE, NICHT IM LIEFERUMFANG	12
3 EINRICHTUNG	13
3.1 ABNAHME UND INSPEKTION	13
3.2 HEBEN UND MONTAGE	13
3.3 GEFAHREN BEI DER INSTALLATION	15
3.3.1 Waagerechte Montage	16
3.3.2 Senkrechte Montage	16
3.3.3 Über-Kopf-Montage	17
3.4 ZUSAMMENBAU DER MASCHINE	17
3.4.1 Zentrierung und Nivellierung	18
3.4.2 Installation der Schneidspitze oder des Einsatzhalters	19
3.4.3 Drehung des Werkzeugkopfes	20
3.4.4 Einstellung des Vorschubs	20
3.4.5 Installation des Antriebsmotors	21
3.4.6 Anschluss des Air Caddy	21
4 BETRIEB	23
4.1 PRÜFUNG VOR DER INBETRIEBNAHME	23
4.2 BETRIEBSARTEN	23
4.2.1 Einrichtung für das Flanschdrehen	23
4.2.2 Einrichtung für das Senken	24
4.2.3 Installation für Rückseiten-Bearbeitung	24

INHALTSVERZEICHNIS (FORTSETZUNG)

KAPITEL/ABSCHNITT	SEITE
4.3 BETRIEB	25
4.3.1 Starten der Maschine	25
4.3.2 Anhalten der Maschine	26
4.3.3 Korrektur der Maschineneinstellung	26
5 WARTUNG	27
5.1 CHECKLISTE FÜR DIE WARTUNG	27
5.2 ZUGELASSENE SCHMIERMITTEL	27
5.3 WARTUNGSAUFGABEN	28
5.3.1 Prüfung des Öltanks und des Behälters am Partikelfilter des Air Caddy	28
5.3.2 Prüfung des Ausfall-Signalkreises am Air Caddy	29
5.3.3 Test des Not-Halt-Schalters	29
5.3.4 Zapfen-Führungen	29
5.3.5 Montage und Entfernen der Schutzvorrichtungen	29
5.3.6 Walzen-Einstellung	30
5.4 FEHLERBEHEBUNG	31
5.4.1 Die Maschine dreht nicht	31
5.4.2 Der Vorschub funktioniert nicht	31
5.4.3 Die Maschine liefert ein schlechtes Ergebnis	31
5.4.4 Die Maschine schneidet nicht plan	31
6 LAGERUNG UND TRANSPORT	33
6.1 LAGERUNG	33
6.1.1 Kurzfristige Lagerung	33
6.1.2 Langfristige Lagerung	33
6.2 TRANSPORT	34
6.3 ENTSORGUNG	34
ANHANG A MONTAGEZEICHNUNGEN	35
ANHANG B SDS	55

LISTE DER ABBILDUNGEN

ABBILDUNG	SEITE
1-1 ODF60 Platzierung der Kennzeichnung	8
1-2 60220 Platzierung der Kennzeichnung (unter der Maschine)	8
2-1 Installierter Befestigungssatz	9
2-2 Steuereinheiten am Air Caddy	10
2-3 OD60 Speed facer Abmessungen (P/N 86990)	11
3-1 Hebepunkte (Modell ODF40 im Bild)	14
3-2 Gefahr von oben	15
3-3 Hinweise zur Montage	16
3-4 Alternative Montage-Bohrung	17
3-5 Positionen der Bolzen und Bohrungen	18
3-6 Komponenten des Justierfusses	18
3-7 Feinanzeiger für das Nivellieren	19
3-8 Position der Klemmschraube für den Schwenkwinkel	19
3-9 Position der Vorschub-Mitnehmer	20
3-10 Einstellungen des Vorschubs	21
3-11 Angeschlossener Druckluftmotorantrieb	21
4-1 Befestigungsschrauben der Stelleiste	24
4-2 Komponenten der Rückseiten-Einheit	25
4-3 Steuereinheiten am Air Caddy	25
4-4 Einstellschraube für Vorschub und Knopf für die Richtung des Vorschubs	26
5-1 Ringschlüssel hinter dem Schraubenkopf	29
5-2 Dorn als Hilfe bei der Montage der Schutzvorrichtung	30
5-3 Walzen-Einstellspanner (P/N 86988)	30
6-1 ODF60 Transportkiste	34
A-1 ODF60 Flanschdrehmaschine assembly (P/N 86990)	36
A-2 ODF60 Flanschdrehmaschine labels assembly (P/N 86990)	37
A-3 ODF60 Flanschdrehmaschine parts list (P/N 86990)	38
A-4 Montage des Schiebwerkzeughalters (P/N 79790)	39
A-5 Teileliste des Schiebwerkzeughalters (P/N 79790)	40
A-6 Montage des Druckluftantriebs (P/N 83430)	41
A-7 Montage des Druckluftantriebs (P/N 83430)	42
A-8 Montage des Justierfusses (P/N 86880)	43
A-9 Montage der radialen Achse (P/N 86890)	44
A-10 Teileliste der radialen Achse (P/N 86890)	45
A-11 Montage des Zugseil-Vorschubkastens (P/N 86900)	46
A-12 Montage Schalters im Zugseil-Vorschubkasten (P/N 86900)	47
A-13 Montage der Vorschubeinheit (P/N 86910)	48
A-14 Zusammenbau Spannfuß (P/N 86970)	49
A-15 Montage des Antriebsmotors (P/N 86989)	50
A-16 Montage des Befestigungssatzes (P/N 87164)	51
A-17 Montage des Rückseiten-Montagesatzes (P/N 87310)	52

Diese Seite bleibt absichtlich unbeschriftet

LISTE DER TABELLEN

TABELLE	SEITE
1-1 Lärmpegel	3
1-2 Checkliste der Risikobewertung vor dem Einrichten	5
1-3 Checkliste der Risikobewertung nach dem Einrichten	5
1-4 ODF60 Flanschdrehmaschine Kennzeichnung	6
2-1 Gewicht der einzelnen Komponenten	12
3-1 ODF60 Montagefüsse	18
5-1 Wartungsintervalle und -Aufgaben	27
5-2 Zugelassene Schmiermittel	28
A-1 Werkzeugsatz P/N 78530	53

Diese Seite bleibt absichtlich unbeschriftet

1 EINLEITUNG

INHALT:

1.1 VERWENDUNG DIESES HANDBUCHS	1
1.2 SICHERHEITSHINWEISE	1
1.3 ALLGEMEINE SICHERHEITSMASSNAHMEN	2
1.4 MASCHINEN-SPEZIFISCHE SICHERHEITSMASSNAHMEN	3
1.5 RISIKOBEWERTUNG UND -REDUZIERUNG	4
1.6 CHECKLISTE DER RISIKOBEWERTUNG	5
1.7 KENNZEICHNUNG	6
1.7.1 KENNZEICHNUNGSART	6
1.7.2 PLATZIERUNG DER KENNZEICHNUNG	7

1.1 VERWENDUNG DIESES HANDBUCHS

Dieses Handbuch enthält die wichtigsten Informationen zur Einrichtung, zum Betrieb, zur Wartung, zur Lagerung, zum Transport und zur Entsorgung der ODF60 Flanschdrehmaschine.

Auf der ersten Seite eines jeden Kapitels befindet sich eine Zusammenfassung der jeweiligen Inhalts, damit spezielle Informationen schneller gefunden werden können. In den Anhängen befinden sich zusätzliche Produktinformationen, die Hilfe bei der Einrichtung, dem Betrieb und der Wartung der Maschine bieten.

Lesen Sie das gesamte Handbuch, damit Sie selbst mit der ODF60 Flanschdrehmaschine vertraut werden, bevor sie ihn einstellen oder damit arbeiten.

1.2 SICHERHEITSHINWEISE

Beachten Sie besonders aufmerksam die Sicherheitshinweise, die in diesem Handbuch vorkommen. Die Sicherheitshinweise dienen dazu, sie auf spezielle Gefahrensituationen hinzuweisen, die beim Betrieb dieser Maschine entstehen können.

Beispiele für in diesem Handbuch vorkommende Sicherheitshinweise finden sie hier¹:

GEFAHR

Weist auf eine gefährliche Situation hin, die, falls sie nicht vermieden wird, Gefahr für das Leben oder schwere Verletzungen birgt.

WARNUNG

Weist auf eine gefährliche Situation hin, die, falls sie nicht vermieden wird,, mögliche Gefahr für das Leben oder schwere Verletzungen birgt.

1. Weitere Informationen über Sicherheitshinweise finden Sie in *ANSI/NEMA Z535.6-2011, Product safety Information in Product Manuals, Instructions, and Other Collateral Materials.*

VORSICHT

Weist auf eine gefährliche Situation hin, die, falls sie nicht vermieden wird, eine mögliche Gefahr für geringe oder leichte Verletzungen birgt.

ANMERKUNG

Weist auf eine gefährliche Situation hin, die, falls sie nicht vermieden wird, eine mögliche Beschädigung der Maschine und Schaden an der Ausrüstung oder unerwünschte Ergebnisse bei der Bearbeitung verursacht.

1.3 ALLGEMEINE SICHERHEITSMASSNAHMEN

H&S ist wegweisend in der Umsetzung des sicheren Einsatzes von tragbaren Werkzeugmaschinen. Die Sicherheit ist jeden Einsatz wert. Sie, als Endbenutzer, müssen Ihren Teil dazu beitragen und auf Ihre Arbeitsumgebung aufpassen und sich eng an die hier folgenden, in diesem Handbuch enthaltenen, Bedienungs- und Sicherheitsanweisungen halten, was auch für die Richtlinien für Ihre Mitarbeiter gilt.

Beachten Sie die folgenden Sicherheitsvorkehrungen, während Sie mit oder in der Nähe der Maschine arbeiten.

Schulung - Bevor Sie mit dieser oder jeder anderen Werkzeugmaschine arbeiten, sollten Sie durch einen qualifizierten Trainer eingewiesen werden. Setzen Sie sich mit H&S bezüglich spezieller Einweisungen für diese Maschinen in Verbindung.

Risikoeinschätzung - Die Arbeit mit und in der Umgebung der Maschine ist mit Risiken für Ihre Sicherheit verbunden. Sie sind als Endbenutzer verantwortlich für den Betrieb und die Sicherheitseinschätzung für jedes Arbeitsumfeld, bevor Sie die Maschine einrichten und mit ihr arbeiten.

Bestimmungsgemäßer Einsatz - Setzen Sie diese Maschine in Übereinstimmung mit den Anweisungen und Sicherheitshinweisen aus diesem Handbuch ein. Verwenden Sie diese Maschine nicht für andere Arbeiten, als die, die in diesem Handbuch als bestimmungsgemäß genannt und beschrieben sind.

Persönliche Schutzausrüstung - Tragen Sie immer Ihre persönliche Schutzausrüstung, wenn Sie mit dieser oder irgendeiner anderen Werkzeugmaschine arbeiten. Wenn Sie mit dieser Maschine arbeiten, ist Feuerhemmende Kleidung mit langen Ärmeln und Beinen empfohlen. Heiße Späne, die sich von dem bearbeiteten Stück lösen, können sich in die unbedeckte Haut einbrennen.

Arbeitsbereich - Halten Sie den Bereich um die Maschine von störenden Dingen frei. Sichern Sie Kabel oder Schläuche, die mit der Maschine verbunden sind. Entfernen Sie andere Kabel oder Schläuche aus dem Arbeitsbereich.

Heben - Viele Komponenten von H&S-Maschinen sind sehr schwer. Wenn es möglich ist, heben Sie die Maschinenbestandteile mit der Hilfe eines geeigneten Hebezeugs oder Krans. Benutzen Sie immer die dazu vorgesehenen Hebepunkte an der Maschine. Folgen Sie den Anweisungen zum Heben der Maschine, wie sie in diesem Handbuch beschrieben ist.

Abschließen und Abkoppeln - Trennen sie die Maschine von der Stromversorgung und koppeln Sie sie vollkommen ab, bevor Sie die Maschine warten.

Bewegliche Teile - H&S Maschinen haben zahlreiche exponierte bewegliche Teile und Anschlüsse, an denen man sich heftig stoßen und schneiden und andere Verletzungen erleiden kann. Ausgenommen Betriebskontrollen im Stillstand, vermeiden Sie den Kontakt mit den beweglichen Teilen durch Ihre Hände oder Werkzeuge, während die Maschine in Betrieb ist. Ziehen Sie Handschuhe aus und sichern Sie Ihr Haar, Ihre Kleidung, Ihren Schmuck und Umhängetaschen, um zu verhindern, dass sie sich in den beweglichen Teilen der Maschine verfangen.

Scharfe Kanten - Schneidwerkzeuge und Werkstücke haben scharfe Kanten, an denen Sie sich leicht schneiden können. Tragen Sie Schutzhandschuhe und seien sie vorsichtig, wenn Sie an den Werkzeugen oder den Werkstücken arbeiten.

Heiße Flächen - Während des Betriebs können die Motoren, Pumpen, HPUs und die Schneidwerkzeuge so heiß werden, dass man sich daran verbrennen kann. Achten sie auf die Warnhinweise auf heiße Oberflächen und

vermeiden sie den Kontakt mit blanker Haut, bis

die Maschine abgekühlt ist.

1.4 MASCHINEN-SPEZIFISCHE SICHERHEITSMASSNAHMEN

Gefahr für die Augen - An dieser Maschine entstehen während des Betriebs Metallsplinter. Tragen Sie beim Betrieb dieser Maschine immer einen Sichtschutz.

Gefährliches Umfeld - Betreiben sie diese Maschine nicht in einer Umgebung, in der sich potentiell explosives Material oder giftige Chemikalien befinden, oder die Strahlungsgefährdet ist.

Lärmpegel - Diese Maschine produziert potentiell gefährlichen Lärm. Wenn Sie an der Maschine oder in deren Nähe arbeiten, müssen Sie einen Gehörschutz tragen. Während der Testphase hat die Maschine Lärmpegel¹ entwickelt, die in der

Tabelle aufgeführt sind. 1-1.

TABELLE 1-1. LÄRMPEGEL

	Motor
Lärmstärke	102,3 dBA
Lärmdruck für Betreiber	87,6 dBA
Lärmdruck in der Umgebung	85 dBA

1. Der Maschinentest ist in Übereinstimmung mit den harmonisierten Europäischen Standards EN ISO 3744:2010 und EN 11201:2010 durchgeführt worden.

Einrichten der Maschine -Nehmen Sie die Maschine niemals in Betrieb, wenn sie nicht entsprechend der Vorgaben aus diesem Handbuch am Werkstück eingerichtet ist. Wenn die Maschine über Kopf oder senkrecht eingerichtet wird, lösen Sie die Hebevorrichtung nicht, bevor die Maschine in Übereinstimmung mit den Vorgaben

aus diesem Handbuch am Werkstück eingerichtet ist.

Prüfen Sie bei jeder Einrichtungs-Position, ob die Maschine so gesichert ist, dass sie, falls sie rutschen oder rotieren sollte, keine Verletzungen oder Schäden verursacht.

1.5 RISIKOBEWERTUNG UND -REDUZIERUNG

Die Werkzeuge der Maschine sind eigens dazu entworfen, eine genaue Material-Abtragung vorzunehmen.

Stationäre Werkzeugmaschinen umfassen Drehbänke und Fräsen und werden üblicherweise von Werkzeughändlern vertrieben. Sie werden an einem festen Platz aufgestellt und dort betrieben und gelten als eigenständige Maschine. Stationäre Werkzeugmaschinen verfügen über die Steifheit, die für die Material-Abtragung benötigt wird, durch ihren Rahmen, der Bestandteil der Werkzeugmaschine ist.

Tragbare Werkzeugmaschinen sind dafür entwickelt, vor Ort eingesetzt zu werden. Sie werden typischerweise direkt am Werkstück selbst montiert, oder an einem daran befestigten Rahmen und sie erhalten ihre Steifheit von dem Rahmen/Werkstück, an dem sie

montiert sind. Die Vorgabe des Designs ist, dass die tragbare Werkzeugmaschine und der Rahmen/das Werkstück, an dem sie montiert ist, zusammen während des Bearbeitungsprozesses eine komplette Maschine werden.

Um nun die gewünschten Ergebnisse zu erhalten und dabei die Sicherheit zu wahren, muss der Bediener die hier folgende Absicht im Design, das Einrichten und die Bedienungsarten verstehen, die die Einzigartigkeit der tragbaren Werkzeugmaschinen darstellen.

Der Bediener muss für den beabsichtigten Einsatz vor Ort eine allumfassende Kontrolle und Risikoeinschätzung durchführen. Es ist wegen der einzigartigen Beschaffenheit der tragbaren Werkzeugmaschinen durchaus möglich, dass eine oder mehrere Gefahrenquellen bestehen.

Bei der Arbeit mit diesen Maschinen ist die Risikoeinschätzung vor Ort und die Berücksichtigung der tragbaren Werkzeugmaschine im Zusammenhang mit dem Werkstück besonders wichtig.

1.6 CHECKLISTE DER RISIKOBEWERTUNG

Die hier folgende Checkliste hat keinen Anspruch auf Vollständigkeit, es werden aber die Dinge erwähnt, die beim Einrichten und dem Betrieb der tragbaren Werkzeugmaschine wichtig sind.

In jedem Fall sind diese Checklisten typisch für die Art der Risiken, die der Einrichter und der Betreiber berücksichtigen sollten. Verwenden Sie diese Checkliste als Teil Ihrer Risikobewertung:

TABELLE 1-2. CHECKLISTE DER RISIKOBEWERTUNG VOR DEM EINRICHTEN

Vor dem Einrichten	
<input type="checkbox"/>	Alle Warnhinweise an der Maschine wurden betrachtet.
<input type="checkbox"/>	Alle festgestellten Risiken wurden gesichert oder entdeckt (herunterhängende, schneidende, brechende, verwickelte, abscherende oder herunterfallende Gegenstände).
<input type="checkbox"/>	Es wurde der Bedarf an Personal für die Sicherung berücksichtigt und alle Sicherheitsmaßnahmen ergriffen.
<input type="checkbox"/>	Es wurden die Anleitungen für die Einrichtung der Maschine (Abschnitt 3.3) gelesen und es wurde ein Inventar mit allen erforderlichen, aber nicht gelieferten Gegenständen (Abschnitt 2.5) erstellt.
<input type="checkbox"/>	Es wurde ein Hebeplan erstellt, einschließlich der entsprechenden Befestigung, und zwar für jeden Hebevorgang, der während dem Einrichten der Halterung und der Maschine erforderlich ist.
<input type="checkbox"/>	Es wurden alle möglichen Fallwege beim Anheben und Einrichten berücksichtigt. Es wurden Vorsichtsmaßnahmen ergriffen, damit die Arbeiter sich von diesen Fallwegen fernhalten.
<input type="checkbox"/>	Es wurde berücksichtigt, wie diese Maschine arbeitet und dementsprechend der beste Standort für die Steuerung, die Kabel und den Bediener gewählt.
<input type="checkbox"/>	Es wurde jedes weitere Risiko im Arbeitsbereich erkannt und bewertet.

TABELLE 1-3. CHECKLISTE DER RISIKOBEWERTUNG NACH DEM EINRICHTEN

Nach dem Einrichten	
<input type="checkbox"/>	Es wurde geprüft, ob die Maschine sicher installiert ist (in Übereinstimmung mit Abschnitt 3) und ob die möglichen Fallwege frei sind. Wenn die Maschine in einer hohen Position installiert ist, wurde geprüft, ob sie gegen den Absturz gesichert ist.
<input type="checkbox"/>	Es wurden alle möglichen Punkte, an denen man sich einklemmen kann, geprüft, wie zum Beispiel rotierende Teile, und es wurde das beteiligte Personal darüber informiert.
<input type="checkbox"/>	Es wurde ein Behälter für Späne oder anderen Abfall bereitgestellt, der durch den Betrieb der Maschine entsteht.
<input type="checkbox"/>	Es wurden die erforderlichen Wartungsintervalle berücksichtigt (Abschnitt 5.1) und die entsprechenden Schmiermittel (Abschnitt 5.2) verwendet.
<input type="checkbox"/>	Es wurde geprüft, ob alle beteiligten Mitarbeiter über die empfohlene persönliche Schutzausrüstung verfügen und die vor Ort geforderten Bestimmungen kennen.
<input type="checkbox"/>	Es wurde geprüft, ob das beteiligte Personal die Gefahrenzone kennt und sich davon fernhält.
<input type="checkbox"/>	Es wurde jedes weitere Risiko im Arbeitsbereich erkannt und bewertet.

1.7 KENNZEICHNUNG

1.7.1 Kennzeichnungsart

Die hier folgenden Warnhinweise sollten an Ihrer Maschine angebracht sein. Wenn Kennzeichen falsch angebracht sind oder fehlen, nehmen Sie bitte sofort mit H&S Kontakt auf, damit der Fehler behoben wird.

TABELLE 1-4. ODF60 FLANSCHDREHMASCHINE KENNZEICHNUNG











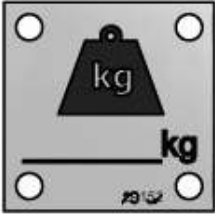



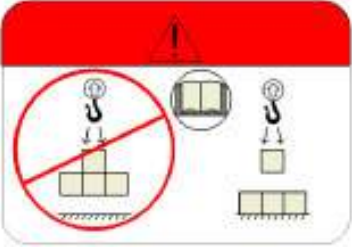

	<p>P/N 29152 Massenangaben</p>		<p>P/N 46902 Warnhinweis: Heiße Oberfläche</p>
	<p>P/N 59039 Warnhinweis: Hebepunkt</p>		<p>P/N 59042 Warnhinweis: Gefahr für die Hände: Schnittverletzung durch bewegliche Teile</p>
<p>HOSE ARR </p> <p>BASE </p>	<p>PN 60219 Schlauchanschluss-Schema für rot-rot/ blau-blau</p>	<p>HOSE ARR </p> <p>BASE </p>	<p>PN 60220 Schlauchanschluss-Schema für blau-rot/ rot-blau</p>
	<p>PN 79324 Warnhinweis: Gefahr für die Hände: Einklemmen durch bewegliche Teile</p>		<p>PN 79385 Warnhinweis: Nur einen Teil vor dem Zusammenbau anheben, im Handbuch nachlesen</p>

TABELLE 1-4. ODF60 FLANSCHDREHMASCHINE KENNZEICHNUNG

		PN 84856 Warnhinweis: Sichern Sie die Maschine gegen Absturz	
		PN 87261 H&S ODF60 Flanschdrehmaschine Kennzeichnung	
	PN 87265 Schwarzer Pfeil auf gelbem Grund		PN 87269 H&S Serienschild
	PN 87271 Warnhinweis: Verwenden Sie Sicht- und Gehörschutz, und lesen Sie die Betriebsanleitung		PN 87272 Schild: Made in the USA
		PN 87429 H&S ODF60 Kennzeichnung	

1.7.2 Platzierung der Kennzeichnung

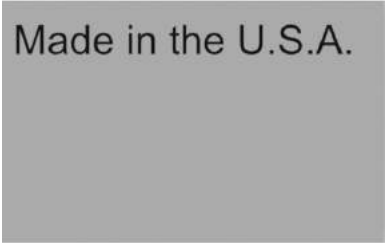
Die folgenden Darstellungen zeigen die Platzierung der Kennzeichnungen auf jeder Komponente der ODF60 Flanschdrehmaschine.

Die weiteren Hinweise auf Platzierungen der Hinweise beziehen sich auf die Explosionszeichnungen in Anhang A.



ABBILDUNG 1-1. ODF60 PLATZIERUNG DER KENNZEICHNUNG

Kennzeichnung P/N: 29152, 46902, 59039, 59042, 60219, 79324, 79385, 84856, 87261, 87265, 87269, 87271, 87272, 87429



ABBILDUNG 1-2. 60220 PLATZIERUNG DER KENNZEICHNUNG (UNTER DER MASCHINE)

Kennzeichnung P/N: 60220

2 ÜBERSICHT

INHALT:

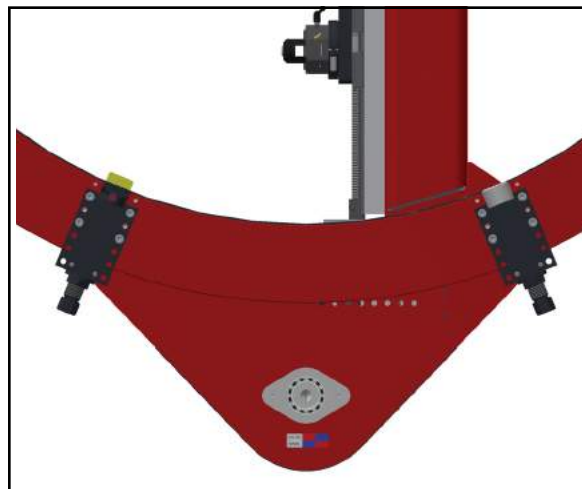
2.1 EIGENSCHAFTEN UND KOMPONENTEN	- 9
2.2 STEUERUNG	10
2.3 ABMESSUNGEN	10
2.4 SPEZIFIKATIONEN	12
2.5 ERFORDERLICHE TEILE, NICHT IM LIEFERUMFANG	12

2.1 EIGENSCHAFTEN UND KOMPONENTEN

Die ODF60 Flanschdrehmaschine ist eine tragbare, am Außendurchmesser (OD) montierte, Einzelpunkt Flanschdrehmaschine, mit Druckluft- und Keilriemenantrieb, zum Einsatz an Werkstücken mit einem Außendurchmesser von 49.1-60.5" (1,247-1,537 mm), oder 39.1-50.0" (993-1270 mm) mit dem optional erhältlichen Befestigungssatz (siehe Abbildung 2-1).



FIGURE 2-1. INSTALLIERTER BEFESTIGUNGSSATZ

Hier folgend werden die wichtigsten Komponenten aufgezählt:

Druckluftmotor - Der Druckluftmotor hat 1,35 PS, ist reversibel und kann, abhängig von Hindernissen oder dem Betriebsmodus sowohl über als auch unter der Maschine montiert werden.

Werkzeugbrücke mit radialem Verfahrensweg - Im radialen Verfahrensweg sind die linearen Strecken und eine verschiebbare Kugelumlaufspindel mit 13,9" (353 mm) platziert. Diese Spindel kann in der Brücke für den Schnittbereich vom maximalen Außendurchmesser bis zum Nullpunkt in der Mitte eingestellt werden.

Montage des Werkzeughalters - Der Winkel des Werkzeugkopfes kann ebenfalls um 360°

gedreht werden, um axial auf einen Anlegewinkel eingestellt zu werden. Der Anschlag des Werkzeugs kann unabhängig gedreht werden, um die Geometrie des Werkzeugs zu erhalten. Die radiale und die axiale Position kann manuell mit Hilfe einer 3/8" Ratsche eingestellt werden.

Automatische Vorschubeinheit - Die Automatische Vorschubeinheit ersetzt den manuellen Vorschub des Werkzeugs während des Arbeitsganges. ODF60 Flanschdrehmaschine enthält auch vier Vorschub-Mitnehmer, mit denen die einstellbare Vorschubeinheit gesteuert wird. Der Vorschub kann an beiden Achsen von 0,001-0,032" (0,03-0,8 mm) pro Umdrehung eingestellt werden.

Montage des Spannfußes - Der Spannfuß ist nur für die Außenspannung vorgesehen. Die verstellbaren Spannpratzen haben verstellbare Schenkel und ermöglichen das Zentrieren der Maschine mit Hilfe von Einstellzeigern. Weitere Hinweise zur Montage, siehe Abschnitt 3.3 auf Seite 15.

Rückseiten-Befestigung - Die optionale Rückseiten-Befestigung ermöglicht den Zugriff auf die Maschine, wenn es Hindernisse für die Brücke gibt. Sie kann auch für die Rückseiten-Bearbeitung von Rohrflanschen benutzt werden.

2.2 STEUERUNG

Die ODF60 Flanschdrehmaschine-Steuerung befindet sich im Druckluftantrieb (Air Caddy), der Abbildung 2-2 gezeigt wird.



ABBILDUNG 2-2. STEUER-EINHEITEN AM AIR CADDY

! WARNUNG

Sie müssen immer die Maschine anhalten und den Air Caddy ausschalten/abkoppeln, bevor Sie Einstellungen oder Kontrollen an den Komponenten der Maschine vornehmen. Werden diese Vorsichtsmaßnahmen nicht berücksichtigt, kann das zu schweren Verletzungen führen.

Notabschaltung

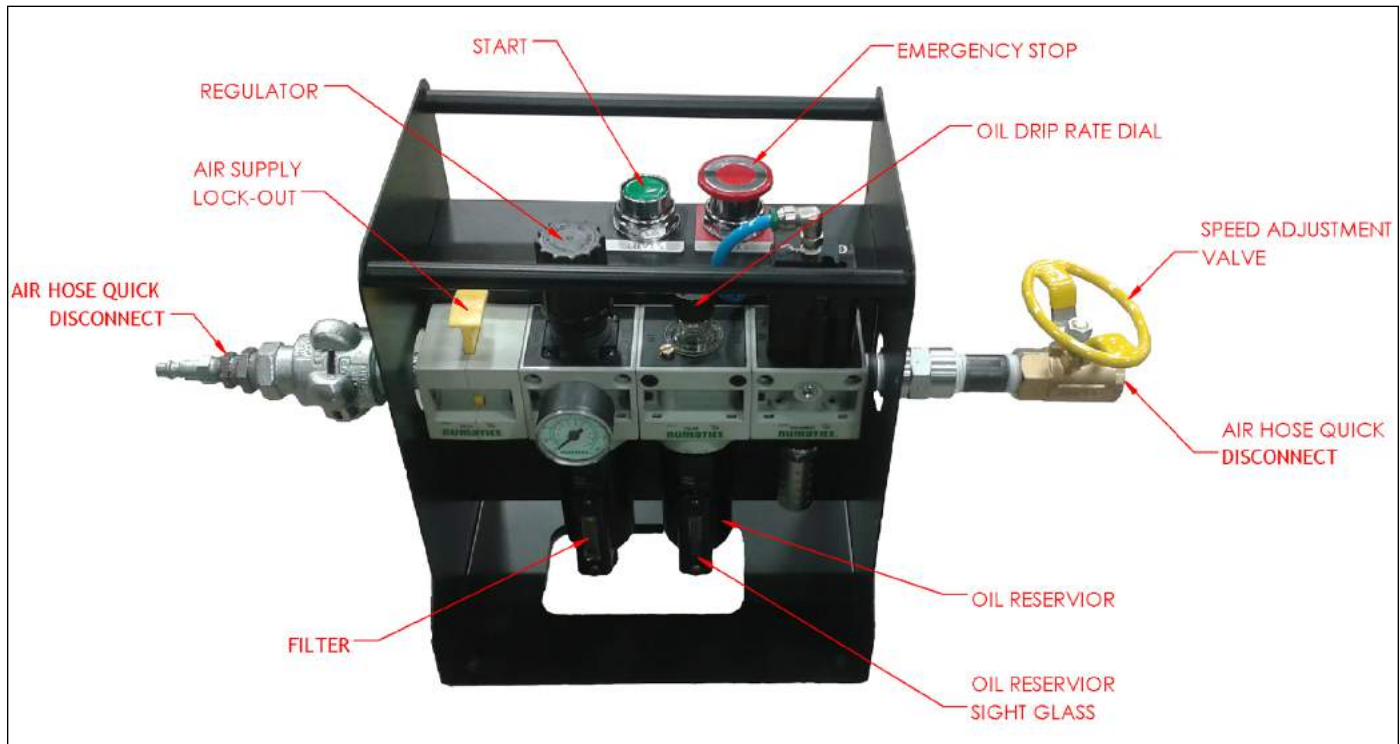
Um die Maschine umgehend anzuhalten, muss der NOT-HALT-Taster (EMERGENCY STOP) am Air Caddy gedrückt werden.

Bevor der ODF60 Flanschdrehmaschine wieder gestartet wird, muss wie folgt vorgegangen werden:

1. Schließen Sie das Ventil der Geschwindigkeitsregelung.
2. Ziehen Sie den NOT-HALT-Taster (EMERGENCY STOP) heraus.
3. Drücken Sie den START-Taster (wiederholen Sie Schritt 1, falls nötig).

2.3 ABMESSUNGEN

Abbildung 2-3 zeigen die Abmessungen der Maschine und des Arbeitsbereichs.



ABBILDUNG 2-3. OD60 SPEED FACER ABMESSUNGEN (P/N 86990)

2.4 SPEZIFIKATIONEN

TABELLE 2-1. GEWICHT DER EINZELNEN KOMPONENTEN

P/N	Komponente	Gewicht in lbs (kg)
87164	Montagesatz für die Verlängerung der Spannhalterung (8)	je 22,5 (10,2)
87030	Montagesatz für Werkzeug zur Rückseitenbearbeitung	62 (28)
86997	ODF60 Werkzeugbrücke	187 (85)
86996	ODF60 Gegengewicht	83 (38)
86990	ODF60 Flanschdrehmaschine	1,926 (874)

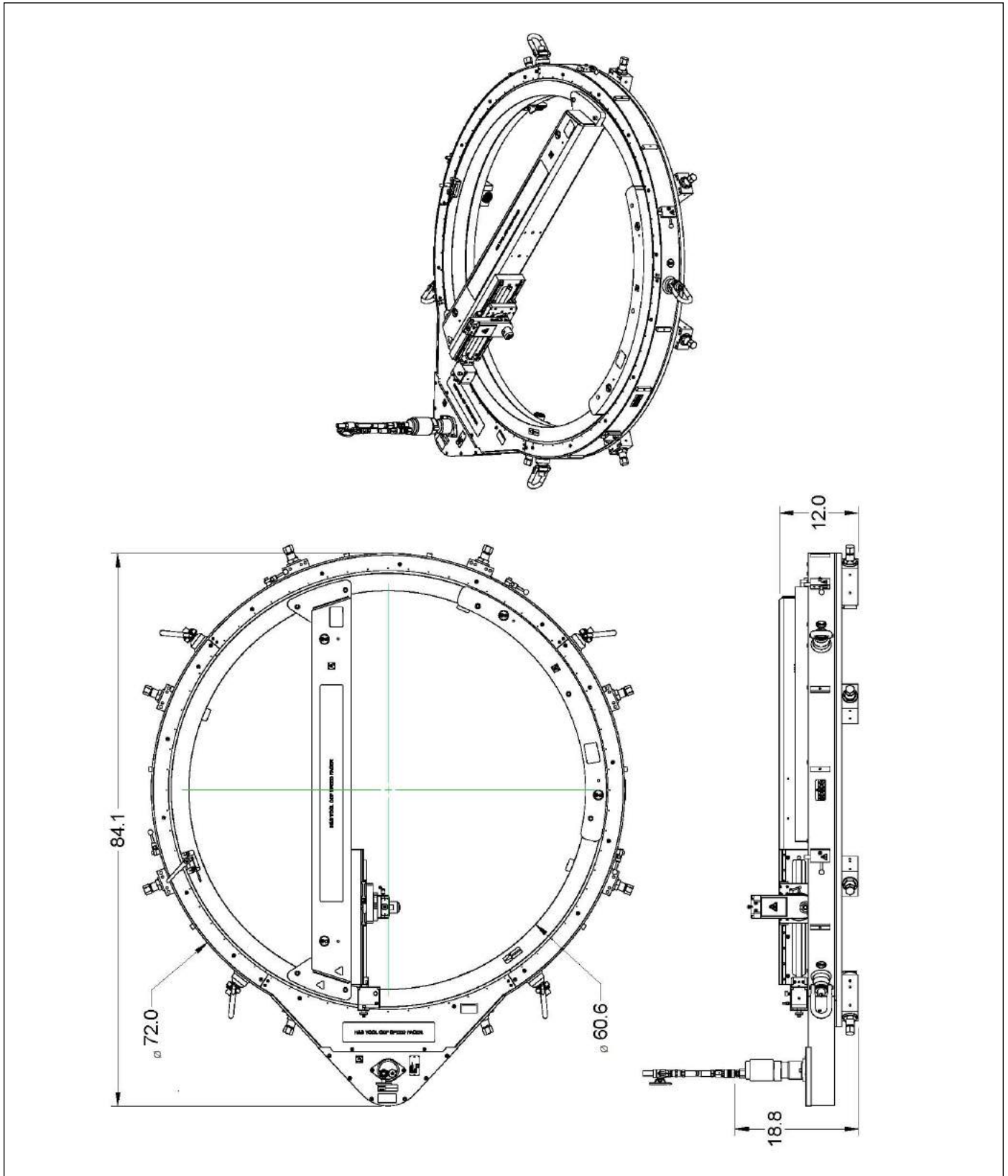
2.5 ERFORDERLICHE TEILE, NICHT IM LIEFERUMFANG

Die folgenden Teile werden benötigt, gehören aber nicht zum Lieferumfang der H&S Produkte:

- Drehmomentschlüssel
- Feinzeiger
- Holzblöcke
- Bandmaß

3 EINRICHTUNG

INHALT:

3.1 ABNAHME UND INSPEKTION	13
3.2 HEBEN UND MONTAGE	13
3.3 GEFAHREN BEI DER INSTALLATION	15
3.3.1 WAAGERECHE MONTAGE	16
3.3.2 SENKRECHTE MONTAGE	16
3.3.3 ÜBER-KOPF-MONTAGE	17
3.4 ZUSAMMENBAU DER MASCHINE	17
3.4.1 ZENTRIERUNG UND NIVELLIERUNG	18
3.4.2 INSTALLATION DER SCHNEIDSPITZE ODER DES EINSATZHALTERS	19
3.4.3 DREHUNG DES WERKZEUGKOPFES	20
3.4.4 EINSTELLUNG DES VORSCHUBS	20
3.4.5 INSTALLATION DES ANTRIEBSMOTORS	21
3.4.6 ANSCHLUSS DES AIR CADDY	21

In diesem Abschnitt werden der Zusammenbau und die Einstellung der ODF60 Flanschdrehmaschine beschrieben.

3.1 ABNAHME UND INSPEKTION

Vor der Versand ist Ihr H&S-Produkt getestet und für normale Transportbedingungen verpackt worden. H&S garantiert nicht für den Zustand, in dem Ihre Maschine ausgeliefert wird.

Wenn Sie Ihr H&S-Produkt erhalten, führen Sie die folgenden Eingangskontrollen durch:

1. Prüfen Sie die Transportbehälter auf Beschädigungen.
2. Prüfen Sie den Inhalt der Transportbehälter gegen die beiliegende Rechnung, um sicher zu sein, dass alle Komponenten transportiert worden sind.
3. Prüfen Sie alle Komponenten auf Beschädigungen.

Kontaktieren Sie H&S umgehend, wenn Sie Beschädigungen oder fehlende Komponenten bemerken.

ANMERKUNG

Bewahren Sie die Transportbehälter und das Verpackungsmaterial für die spätere Lagerung und den Transport der Maschine auf.

Die Maschine wird von H&S mit einem robusten Schutzfilm aus LPS 3 versandt. Das dafür empfohlene Reinigungsmittel ist LPS PreSolve Orange Degreaser. Vor der Inbetriebnahme müssen alle Teile gereinigt werden.

3.2 HEBEN UND MONTAGE

Sie sollten die Checkliste der Risikobewertung in Tabelle 1-2 auf Seite 5 abarbeiten, bevor Sie die Transportbehälter auspacken.

Vor dem Anheben der Maschine stellen Sie sicher, dass alle Teile sicher mit der Maschine verbunden sind.

! GEFAHR

Die ODF60 Flanschdrehmaschine kann bis zu 1,926 lbs (874 kg) 2,159 lbs (979 kg) wiegen, wenn sie vollständig zusammengebaut ist. Befolgen Sie immer die in diesem Handbuch vorgegebenen Bedienungsschritte, die Sicherheitsregeln Ihres eigenen Unternehmens und die vor Ort geltenden Bestimmungen für das Heben schwerer Teile, um gefährliche Verletzungen an Ihrer Person selbst und an anderen Personen zu vermeiden. Solche schweren Verletzungen oder Unfälle können durch unangemessene Hebemethoden verursacht werden.

Das korrekte Heben muss wie folgt durchgeführt werden:

1. Befestigen Sie vier Heberinge an der Maschine, wenn diese nicht bereits vorhanden sind.



ABBILDUNG 3-1. HEBEPUNKTE (MODELL ODF40 IM BILD)

! VORSICHT

Das Herunterfallen oder das Hin- und Herschwingen der Maschine kann beim Bediener und in der Nähe stehenden Personen schwere Verletzungen bewirken. Heben Sie die Maschine ausschließlich an den in Abbildung 3-1 gezeigten 3/4“-Heberingen. Verwenden Sie für das Heben der ODF60 Flanschdrehmaschine nicht die kleineren Heberinge an der Brücke oder dem Gegengewicht.

2. Schlagen Sie das Hebezeug des Kunden an den in der Abbildung gezeigten Heberingen an.

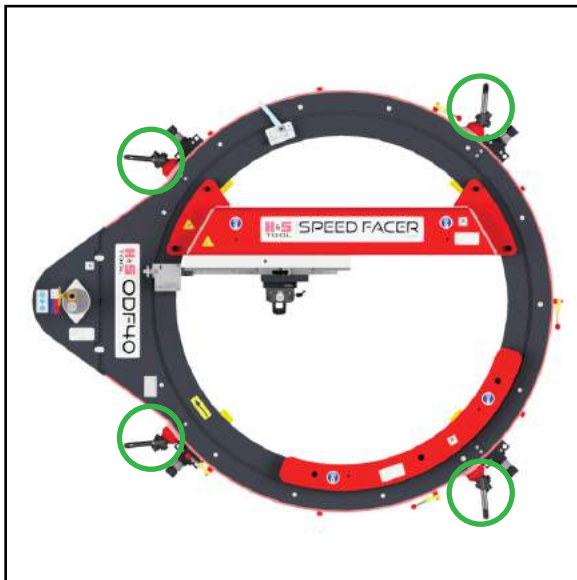
! VORSICHT

Versichern Sie sich, dass das Hebezeug korrekt angeschlagen ist, bevor Sie die Maschine anheben. Heben Sie die Maschine langsam an und stellen Sie sicher, dass keine ihrer Komponenten bei der senkrechten Bewegung nach oben an Hindernissen anstoßen oder verbogen werden. Sollte das Montieren Schwingungen an der Maschine verursachen, setzen Sie sie wieder ab und richten Sie das Hebezeug besser aus.

3. Heben Sie die Maschine aus der Transportkiste.

3.3 GEFAHREN BEI DER INSTALLATION

Die Phase der Installation kann Gefahren bergen, weil es von dem Bediener oder anderem Personal abhängt, ob und wie die empfohlenen Sicherheitsanweisungen befolgt werden. Beachten Sie die folgenden Warnhinweise sorgfältig, bevor Sie mit dem Zusammenbau der Maschine beginnen.



ABBILDUNG 3-2. GEFAHR VON OBEN

! WARNUNG

Wenn sie nicht ordnungsgemäß gesichert ist, kann diese Maschine herunterfallen und lebensgefährliche Verletzungen beim Personal verursachen. Bei der Montage an senkrechten Flanschen und bei der Überkopf-Montage müssen Sie besonders aufmerksam sein.

Vor dem Anheben müssen alle Komponenten sicher mit der Maschine verbunden sein. Verwenden Sie beim Einrichten der Maschine zusätzliches Hebezeug.

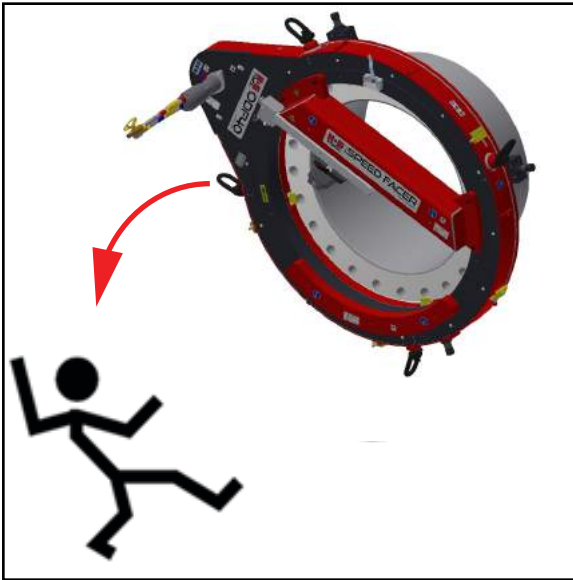

ABBILDUNG 3-3. HINWEISE ZUR MONTAGE

3.3.1 Waagerechte Montage

Die Gefahr bei der waagerechten Montage besteht darin, dass die Maschine nach unten fällt, bis die Brücke auf das Werkstück aufschlägt.

Die folgenden Maßnahmen können dieses Risiko verringern:

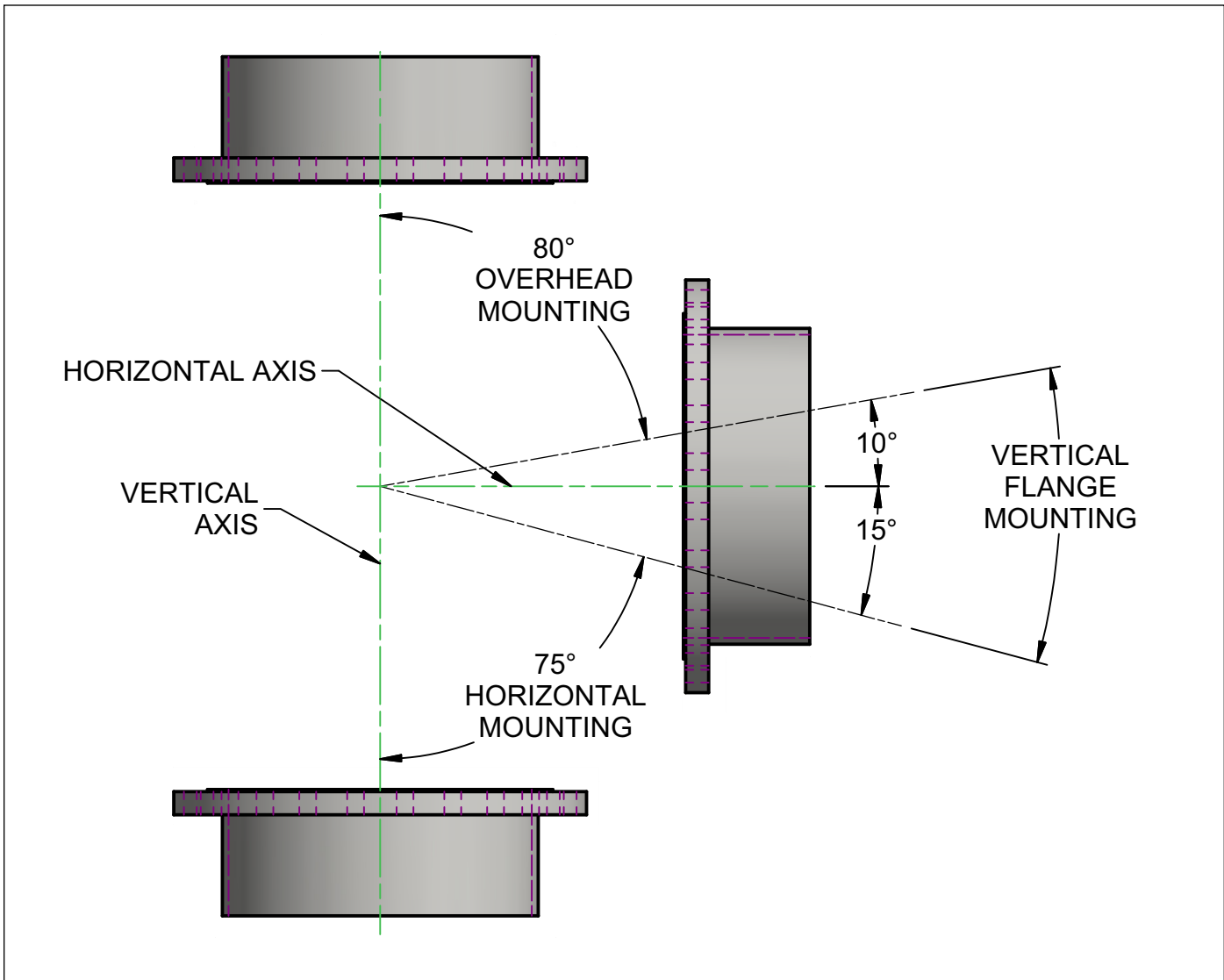
- Belassen Sie die Montagefüße an ihrer Stelle über den Justierfüßen.
- Sollten die Montagefüße entfernt werden müssen, blockieren Sie die Maschine von unten oder sichern Sie sie von oben an Verankerungen über der Maschine, wobei wenigstens zwei gegenüberliegende

Heberinge an den vom Kunden bereitgestellten Ankerpunkten mit für das Gewicht der Maschine und den entsprechenden Angriffswinkel geeigneten Schlingen angeschlagen werden müssen. Siehe Abbildung 3-3.

3.3.2 Senkrechte Montage

Die Gefahr bei der senkrechten Montage besteht darin, dass die Maschine von dem Flansch herunterfällt.

Die folgenden Maßnahmen können dieses Risiko verringern:

- Installieren Sie die Montagefüße auf der Rückseite des Flansches, an der

„Unterseite“ der Justierfüße (siehe Abbildung 3-4).



ABBILDUNG 3-4. ALTERNATIVE MONTAGE-BOHRUNG

- Sollte der Flansch für die Verwendung der Montagefüße zu dick sein, sichern Sie die Maschine an Verankerungen über der Maschine, wobei wenigstens ein Hebering an den vom Kunden bereitgestellten Ankerpunkten mit für das Gewicht der Maschine und den entsprechenden Angriffswinkel geeigneten Schlingen angeschlagen werden muss. Siehe Abbildung 3-3.

3.3.3 Über-Kopf-Montage

Die Gefahr bei der Montage über Kopf besteht darin, dass die Maschine von dem Flansch herunterfällt.

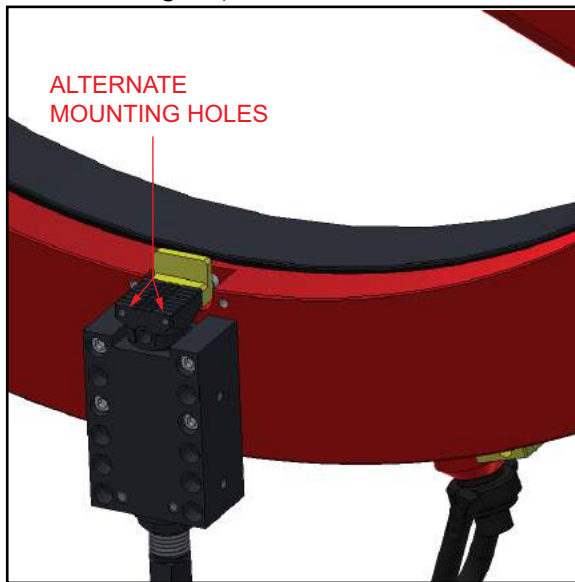
Die folgenden Maßnahmen können dieses Risiko verringern:

- Installieren Sie die Montagefüße (oben) auf der Rückseite des Flansches, an der „Unterseite“ der Justierfüße (siehe Abbildung 3-4).
- Sollte der Flansch für die Verwendung der Montagefüße zu dick sein, sichern Sie die Maschine an Verankerungen über der Maschine, wobei wenigstens zwei gegenüberliegende Heberinge an den vom Kunden bereitgestellten Ankerpunkten mit für das Gewicht der Maschine und den entsprechenden Angriffswinkel geeigneten Schlingen angeschlagen werden müssen. Siehe Abbildung 3-3.

! VORSICHT

In all diesen Fällen sollten die Sicherheitsmaßnahmen während der Risikobewertung erfasst sein und die Halterungen der Maschine so gut passen, dass Schwingungen oder andere Bewegungen der Maschine auf ein absolutes Minimum reduziert sind.

3.4 ZUSAMMENBAU DER MASCHINE

Nehmen Sie die folgenden Einstellungen an der ODF60 Flanschdrehmaschine vor:

1. Arbeiten Sie die Checkliste der Risikobewertung in Tabelle 1-2 auf Seite 5 ab.
2. Messen Sie den Außendurchmesser des Flansches, der bearbeitet werden soll.
3. Setzen Sie die Maschine entsprechend Abbildung 3-1 zum Installieren der 8 Spannfüße auf einer stabilen Unterlage ab.

! WARNUNG

Fehler bei der Montage und der festen Verbindung der Maschine können dazu führen, dass sie sich verdreht oder herunterfällt.



ABBILDUNG 3-5. POSITIONEN DER BOLZEN UND BOHRUNGEN

TABELLE 3-1. ODF60 MONTAGEFÜSSE

Mindestmaß Außendurchmesser in Inch (mm)	Höchstmaß Außendurchmesser in Inch (mm)	Position der Fußbolzen	Position der Rahmenbohrung
57.02 (1,448)	60.5 (1,537)	D	1
55.02 (1,397)	58.5 (1,486)	C	1
53.02 (1,347)	56.5 (1,435)	C	2
51.02 (1,296)	54.5 (1,384)	B	2
49.02 (1,245)	52.5 (1,334)	A	2

- Zentrieren Sie die verstellbare Spannpratzen mit dem verstellbaren RAM an den Justierfüßen.
- Nehmen Sie eine Grobeinstellung der Justierfüße vor (siehe ein Fuß in Abbildung 3-6), indem Sie die Einstellschraube am Fuß ungefähr 1/8" (3 mm) weiter als den Außendurchmesser des Flansches justieren.

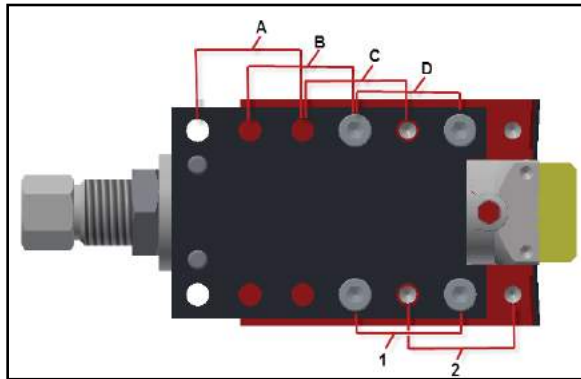

ABBILDUNG 3-6. KOMPONENTEN DES JUSTIERFUSSES

ANMERKUNG

Verstellbare und Standard-Spannpratzen können nur um 1,7" (43 mm) verstellt werden.

- Montieren Sie die Maschine an dem Flansch, indem Sie die Montagefüße an den Bolzenring der Flanschoberfläche anlegen.
- Ziehen Sie die Schrauben der Justierfüße gleichmäßig fest, bis die Backen mit 10 ft-lbs (14 Nm) Drehmoment am Außendurchmesser des Flansches angepresst sind.

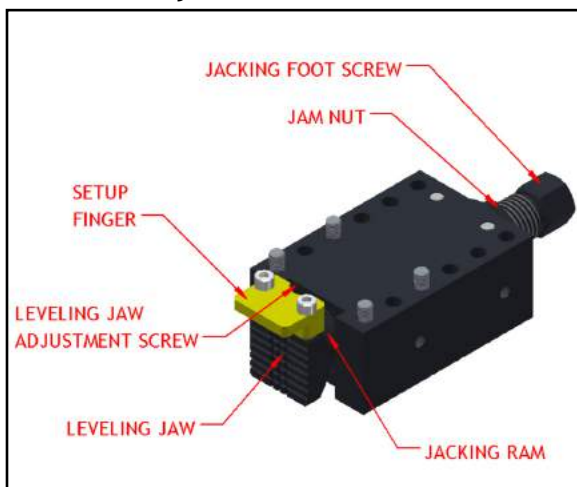
3.4.1 Zentrierung und Nivellierung

Zum Zentrieren und Nivellieren der Maschine gehen Sie wie folgt vor:

- Zur Grobeinstellung prüfen Sie den Abstand zwischen dem Innendurchmesser (ID) der Maschine und dem Außendurchmesser des Rohres an den vier Justierfüßen mit einem Bandmaß.
- Zur Feineinstellung verwenden Sie einen Feinzeiger im Werkzeughalter und prüfen Sie die selben Maße zwischen dem Innendurchmesser der Maschine und dem Außendurchmesser des Rohres. In beiden Fällen erfolgt die Einstellung über die Einstellschrauben an den Füßen.
- Wenn die Montagefüße die Ausgangsstellung erreicht haben, fahren sie wie folgt mit der Feineinstellung fort:
 - Montieren Sie einen Feinzeiger am Werkzeughalter, der über der erhöhten Flanschoberfläche zentriert ist.
 - Stellen Sie den Anzeiger über dem ersten Justierfuß auf Null und drehen Sie die Maschine um 180° auf die Position des Anzeigers auf dem gegenüberliegenden Fuß.
 - Mit der Einstellschraube für das Niveau heben oder senken Sie den Spannpratzen um die Hälfte des Unterschiedes zwischen den beiden Füßen.
 - Wiederholen Sie Schritt b und Schritt c zum Nivellieren der restlichen Justierfüße. Normalerweise muss bei der Maschinenanpassung mit einem Spiel-

raum von 0,10“ (0,25 mm) oder weniger gerechnet werden.



ABBILDUNG 3-7. FEINANZEIGER FÜR DAS NIVELLIEREN

4. Ziehen Sie die 4 Einstellschrauben an den Verstellbaren RAMs rundherum abwechselnd mit einem Drehmoment von 60 ft-lbs (81 Nm) fest.

! WARNUNG

Versichern Sie sich, dass die RAMs mit wenigstens 60 ft-lbs (81 Nm) festgezogen sind. Eine unzureichende Kraft beim Verklemmen kann es zulassen, dass die Maschine sich von dem Werkstück löst, was zu Schäden an der Maschine und Verletzungen oder Tod des Personals führen kann.

ANMERKUNG

Überspannen Sie die Einstellschrauben an den Füßen nicht. Ein Überspannen kann den Rotationsrahmen der Maschine verziehen und zu unerwünschten Bearbeitungsergebnissen führen.

5. Festziehen an den vier Spannfüßen abwechselnd mit bis zu 60 ft-lbs (81 Nm) Drehmoment.
6. Ziehen Sie die Muttern an den Blöcken aller Füße fest.

7. Entfernen Sie die Einrichtungsfinger von den Justierfüßen, wenn dies für die vollständige Bearbeitung des Außendurchmessers notwendig ist. Weitere Informationen zur Sicherung der Maschine, siehe Punkte Abschnitt 3.3 auf Seite 15.

3.4.2 Installation der Schneidspitze oder des Einsatzhalters

ANMERKUNG

Die ODF60 Flanschdrehmaschine ist so entwickelt, dass das Schneidwerkzeug hinter der Brücke hinterhergezogen wird. Die Brücke dreht, gesehen von der Seite der Maschine, an der die Brücke angebracht ist, im Uhrzeigersinn. Dies müssen Sie berücksichtigen, wenn Sie ein neues Werkzeug in die Maschine einsetzen.

Beim Einsetzen der Schneidspitze oder des Einsatzhalters gehen Sie wie folgt vor:

1. Bringen Sie den Werkzeughalter in die richtige Position für den Start der Maschine.
2. Stellen Sie den gewünschten Schwenkwinkel am Werkzeughalter ein (siehe Abbildung 3-8).



FIGURE 3-8. POSITION DER KLEMMSCHRAUBE FÜR DEN SCHWENKWINKEL

3. Vorgehen beim Einbau des geeigneten Werkzeugs in das Schwenkwinkel-Bauteil: Lockern Sie die M20 Werkzeugzangen-Schraube, legen Sie das Werkzeug ein und ziehen Sie die M20-Schraube wieder fest.

TIPP:

Führen Sie das Werkzeug immer so weit wie möglich in den Werkzeughalter hinein. Das erhöht die Stabilität.

4. Stellen Sie das Werkzeug auf die gewünschte Schnitttiefe ein.

3.4.3 Drehung des Werkzeugkopfes

Nehmen Sie die folgenden Einstellungen zum Drehen des Werkzeugkopfes vor:

1. Lösen Sie die beiden Klemmschrauben am Schwenkwinkel-Bauteil, um den runden Klemmkragen an der Rückseite des Werkzeugkopfes zu lösen.

! VORSICHT

Lösen Sie den Werkzeugkopf nicht zu schnell. Halten Sie den Kopf mit einer Hand in einer stabilen Position. Ein schnelles Ausklinken des Werkzeugs kann es unerwartet schwingen lassen, was zu Verletzungen des Personals und Beschädigungen der Maschine führen kann.

2. Position des Werkzeugkopfes.
3. Sichern Sie den Klemmkragen, indem Sie die beiden Klemmschrauben am Schwenkwinkel-Bauteil festziehen.

Eingravierte Markierungen am Klemmkragen ermöglichen die Einstellung der Winkel in $\pm 0,5^\circ$ -Schritten.

3.4.4 Einstellung des Vorschubs

ANMERKUNG

Die Vorschub-Einheit kann sowohl an der radialen als auch der axialen Führung angebracht werden. Dies hängt von der Bearbeitung ab, ob gedreht oder gebohrt werden soll.

Nehmen Sie die folgenden Einstellungen für den Vorschub vor:

1. Installieren Sie die Vorschub-Mitnehmer nach Bedarf (siehe Abbildung 3-9).



ABBILDUNG 3-9. POSITION DER VORSCHUB-MITNEHMER

TIPP:

Die Anzahl der Vorschub-Mitnehmer bestimmt den Vorschub-Wert und die gewünschte Endbearbeitung. Im Lieferumfang sind vier Vorschub-Mitnehmer enthalten. Die Vorschubeinheit kann von 0,001-0,008" (0,003-0,2 mm) Umdrehungen pro Arbeitsgang eingestellt werden. Für genauere Endbearbeitung werden normalerweise zwei Vorschub-Mitnehmer mit gering eingestelltem Vorschub pro Arbeitsgang eingesetzt. Für eine grobe oder schnelle Bearbeitung werden alle vier Vorschub-Mitnehmer eingesetzt.

2. Stellen Sie die Richtung des Vorschubs entsprechend der folgenden Schritte ein, wie dies auch in Abbildung 3-10 gezeigt wird:
 - a) Drücken Sie den Knopf für die Richtung der Vorschubeinheit hinein, um den Vorschub zum Zentrum einzuschalten.
 - b) Ziehen Sie den Knopf für die Richtung des Vorschubs heraus, um den Vorschub zum Außendurchmesser einzuschalten.

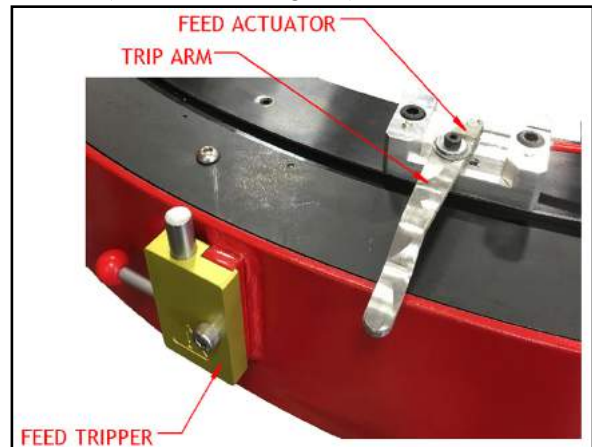
TIPP:

Es kann notwendig sein, den Knopf leicht zu drehen, wenn die Richtung des Vorschubs geändert wird.



ABBILDUNG 3-10. EINSTELLUNGEN DES VORSCHUBS

3. Stellen Sie die Stärke des Vorschubs pro Arbeitsgang ein.

ANMERKUNG

Wenn die Einstellschraube auf den höchsten Wert herausgedreht ist, ist der Vorschub auf den höchsten Wert von annähernd 0,008“ (0,2 mm) pro Arbeitsgang eingestellt. Wenn die Einstellschraube vollständig hineingedreht ist, ist der Vorschub auf den geringsten Wert eingestellt. Mit der Flügelschraube wird der Winkel des Arbeitsgang-Arms am Vorschubschalter verändert.

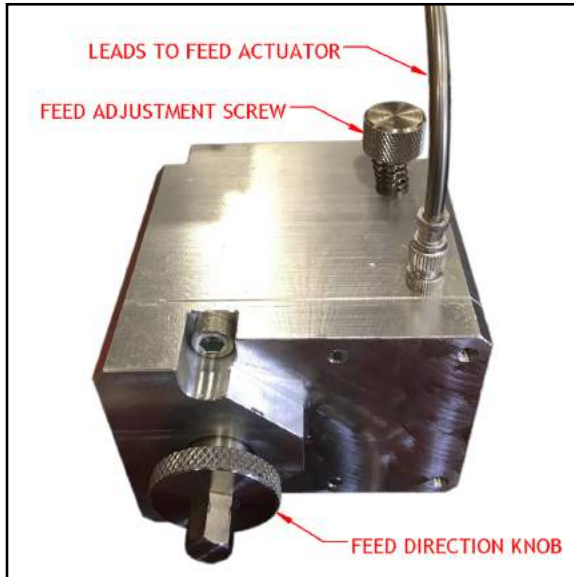
4. Verlegen und sichern Sie das Vorschub-Kabel so, dass es nicht knicken oder sich in Hindernissen verhaken kann.

3.4.5 Installation des Antriebsmotors

Die rot-blauen Aufkleber (P/N 60219, 60220, zu sehen in Tabelle 3-1 auf Seite 18) an beiden Seiten der Maschine an der der Druckluftmotor installiert ist, weisen auf die Schlauchverbindung für die richtige Laufrichtung des Motors hin.

Wenn zum Beispiel der Motor auf der Oberseite montiert ist, wird der rote Schlauch an den roten Motoranschluss angeschlossen. Siehe Abbildung 3-11.



ABBILDUNG 3-11. ANGESCHLOSSENER DRUCKLUFTMOTORANTRIEB

Für die Installation des Antriebsmotors gehen Sie wie folgt vor:

1. Prüfen Sie, ob der Anschlusszapfen im Sitz in der der Motorwelle steckt.
2. Schieben Sie die Antriebswelle in die Nabe und Verbinden Sie den Anschlusszapfen mit dem Sitz in der Antriebsnabe.
3. Ziehen Sie die beiden Schrauben an der Befestigungsmanschette fest.

3.4.6 Anschluss des Air Caddy

Schließen Sie den Air Caddy an die Maschine an das abgekoppelte Geschwindigkeits-Regelungs-Ventil an.

Diese Seite bleibt absichtlich unbeschriftet

4 BETRIEB

INHALT:

4.1 PRÜFUNG VOR DER INBETRIEBNAHME	23
4.2 BETRIEBSARTEN	23
4.2.1 EINRICHTUNG FÜR DAS FLANSCHDREHEN	23
4.2.2 EINRICHTUNG FÜR DAS SENKEN	24
4.2.3 INSTALLATION FÜR RÜCKSEITEN-BEARBEITUNG	24
4.3 BETRIEB	25
4.3.1 STARTEN DER MASCHINE	25
4.3.2 ANHALTEN DER MASCHINE	26
4.3.3 KORREKTUR DER MASCHINENEINSTELLUNG	26

4.1 PRÜFUNG VOR DER INBETRIEBNAHME

Führen Sie vor der Inbetriebnahme der Maschine die folgende Prüfung durch:

- Arbeiten Sie die Checkliste der Risikobewertung in Tabelle 1-3 auf Seite 5 ab.
- Prüfen Sie, ob der Arbeitsbereich frei von unbeteiligten Personal und unnötiger Ausrüstung ist.
- Prüfen Sie, ob der Bereich, in dem sich die Steuerung/die Sichtkontrolle der Maschine befindet, nicht in der Flugrichtung der Metallspäne liegt, wenn die Maschine in Betrieb ist.
- Prüfen Sie, ob die Maschine sicher und in Übereinstimmung mit Abschnitt 3.3 auf Seite 15 an dem Werkstück montiert ist.
- Prüfen Sie, ob alle Luftschläuche montiert und gesichert sind, damit ein Ausklinken, Verwickeln, Schäden durch heiße Späne oder andere Schäden durch eine Störung eines Luftschlauches oder dessen Anschluss vermieden werden.
- Prüfen Sie den Zustand des Werkzeugs auf dessen Schärfe.
- Am Air Caddy müssen Sie prüfen, ob die Ölschmierung auf sechs Öltropfen pro Minute eingestellt ist.
- Prüfen Sie, ob alle Werkzeuge aus der Maschine und deren Arbeitsbereich entfernt worden sind.

4.2 BETRIEBSARTEN

Die ODF60 Flanschdrehmaschine kann an einer flachen oder konischen Flansch die Frontseite bearbeiten, Nuten fräsen oder Flächen abschrägen. In den folgenden Unterpunkten wird erklärt, wie die Maschine für diese Bearbeitungsweisen eingestellt wird. Für Informationen zur Steuerung siehe Abschnitt 2.2 auf Seite 10.

4.2.1 Einrichtung für das Flanschdrehen

Das Plandrehen ist die Grundfunktion des Betriebs der ODF60 Flanschdrehmaschine.

WARNUNG

Nehmen Sie keine Einstellungen oder Anpassungen der Bearbeitungsrichtung vor, wenn die Maschine nicht abgeschaltet ist, die Luftschläuche abgekoppelt und alle erforderlichen Abschaltungen/ Verriegelungen vorgenommen worden sind.

Bei der Einstellung der ODF60 Flanshdrehmaschine für das Bearbeiten der Frontseite einer planen Flansch, gehen Sie wie folgt vor:

1. Bauen Sie die ODF60 Flanshdrehmaschine an dem Werkstück zusammen (siehe Abschnitt 3.3 auf Seite 15).
2. Führen Sie alle Prüfungen durch, die vor der Inbetriebnahme erforderlich sind (siehe Abschnitt 4.1).
3. Lösen Sie beide Befestigungsschrauben, die radiale und die axiale, der Stelleiste.



ABBILDUNG 4-1. BEFESTIGUNGSSCHRAUBEN DER STELLEISTE

4. Mit einer 3/8"-Knarre stellen Sie an der radialen und der axialen Vorschubschrauben die Position des Schneidwerkzeugs auf den Startpunkt für das Schneiden ein.
5. Ziehen Sie nur die axiale Befestigungsschraube der Stelleiste handfest an.
6. Stellen Sie den Knopf für Richtung des Vorschubs in die gewünschte Position (wie dies in Darstellung 4-4 auf Seite 26 gezeigt wird):
7. Stellen Sie die Geschwindigkeit des Vorschubs entsprechend Abschnitt 3.4.4 auf Seite 20 mit Hilfe der Vorschub-Einstellschraube an dem Gehäuse der Vorschubeinheit ein.

4.2.2 Einrichtung für das Senken

Gehen Sie beim Einrichten für das Senken wie folgt vor:

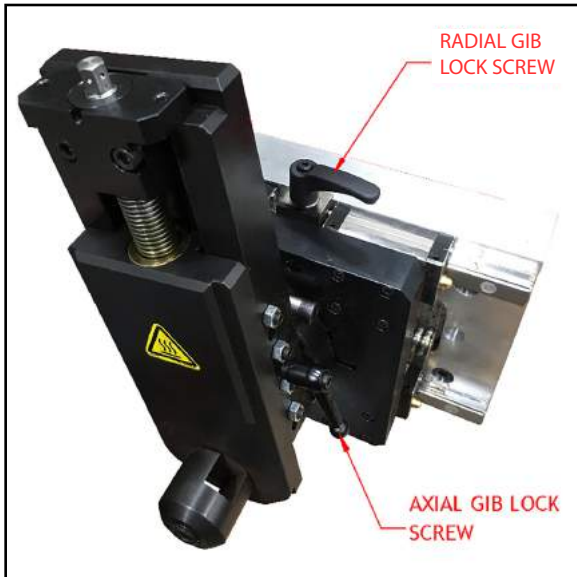
1. Bauen Sie die ODF60 Flanshdrehmaschine an dem Werkstück zusammen (siehe Abschnitt 3.3 auf Seite 15).
2. Führen Sie alle Prüfungen durch, die vor der Inbetriebnahme erforderlich sind (siehe Abschnitt 4.1).
3. Stecken Sie die Vorschubeinheit von der radialen Vorschubschraube auf die axiale Vorschubschraube und sichern Sie sie mit zwei Schrauben.
4. Lösen Sie beide Befestigungsschrauben der Stelleiste, die radiale und die axiale.
5. Mit einer 3/8"-Knarre stellen Sie an der radialen und der axialen Vorschubschrauben die Position des Schneidwerkzeugs auf den Startpunkt für das Schneiden ein.
6. Ziehen Sie nur die radiale Befestigungsschraube der Stelleiste handfest an.
7. Stellen Sie den Knopf für Richtung des Vorschubs in die gewünschte Position. In dieser Einstellung wird das Schneidwerkzeug vom Betreiber weg geführt, wenn er den Knopf für die Vorschubrichtung nach Innen drückt.
8. Stellen Sie die Geschwindigkeit des Vorschubs entsprechend Abschnitt 3.4.4 auf Seite 20 mit Hilfe der Vorschub-Einstellschraube an dem Gehäuse der Vorschubeinheit ein.

4.2.3 Installation für Rückseiten-Bearbeitung

Die ODF60 Flanshdrehmaschine kann auch zusammen mit der optionalen Vorrichtung für die Rückseitenbearbeitung eingesetzt werden. Diese Konfiguration ermöglicht das Bearbeiten von Flanschen, wenn Hindernisse durch das Rohr führen und außerdem kann die Rückseite von verbolzten Flanschen bearbeitet werden.

Gehen Sie beim Einrichten für die Rückseitenbearbeitung wie folgt vor:

1. Bauen Sie sowohl die Brücke als auch das Gegengewicht von der Maschine ab. Beachten Sie dabei die angegebenen Gewichte und verwenden Sie geeignete Hebe- und Bewegungs-

Hilfen, wie sie in Abschnitt 3.2 auf Seite 13 beschrieben sind.

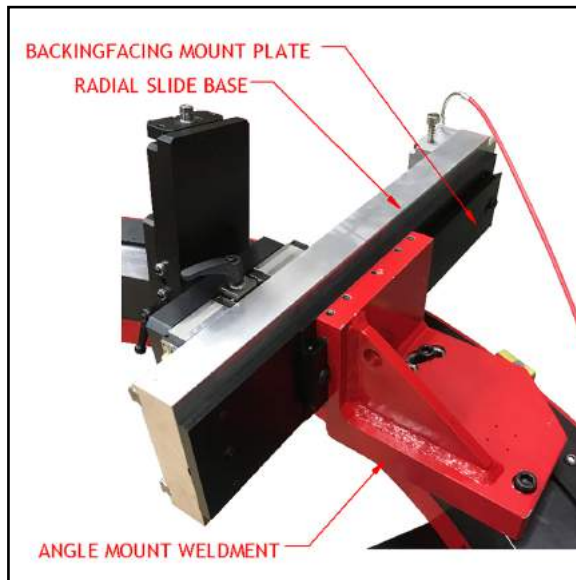

FIGURE 4-2. KOMPONENTEN DER RÜCKSEITEN-EINHEIT

2. Bauen Sie den radialen Schlitten von der Brücke ab und montieren Sie ihn an der Grundplatte für die Rückseitenbearbeitung.
3. Montieren Sie den Winkel-Halter an der Maschine und verwenden Sie dazu die für die Maschinenausführung passenden Bolzen-Bohrungen.
4. Montieren Sie den axialen Schlitten am Winkel-Halter.

4.3 BETRIEB



ABBILDUNG 4-3. STEUEREINHEITEN AM AIR CADDY

4.3.1 Starten der Maschine

Gehen Sie beim Starten der Maschine wie folgt vor:

1. Führen Sie am Air Caddy alle folgenden Arbeitsschritte durch (wie in Abbildung 4-3

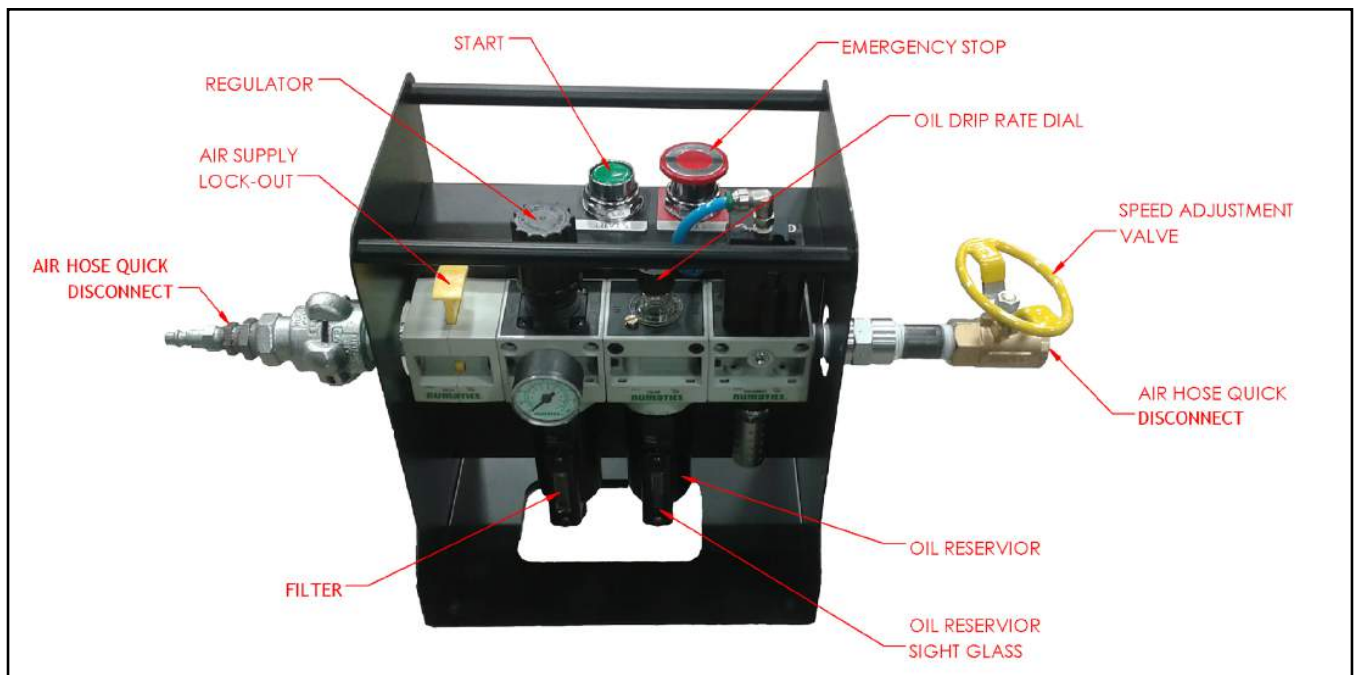
gezeigt wird).

- a) Öffnen sie das DRUCKLUFT-ABSPERRVENTIL.
- b) Ziehen Sie den NOT-HALT-Taster heraus.
- c) Drücken Sie den START-Taster.

- d) Öffnen Sie das GESCHWINDIGKEITS-EINSTELLVENTIL so weit, bis die Rotationsgeschwindigkeit den gewünschten Wert erreicht hat.
2. Stellen Sie die Anzahl der für die Bearbeitungsart erforderlichen Vorschubeinheiten ein (siehe Abschnitt 3.4.4 auf Seite 20).



ABBILDUNG 4-4. EINSTELLSCHRAUBE FÜR VORSCHUB UND KNOPF FÜR DIE RICHTUNG DES VORSCHUBS

3. Bei der Einstellung des Vorschubs gehen Sie wie folgt vor: Halten Sie die Maschine an (siehe Abschnitt 4.3.2 auf Seite 26). Stellen Sie dann die Vorschub-Einstellschraube auf den anfänglichen Schnittwert ein.
4. Stellen Sie den Vorschubwert und die Rotationsgeschwindigkeit so ein, wie es für den gewünschten Arbeitsgang benötigt wird.
5. Regulieren Sie die Öl-Tropf-Frequenz nach Bedarf (siehe Abbildung 4-3).

ANMERKUNG

Für die besten Bearbeitungsergebnisse und längsten Service-Intervalle empfiehlt H&S eine Mindesteinstellung der Öl-Tropf-Frequenz am Air Caddy von sechs Tropfen pro Minute.

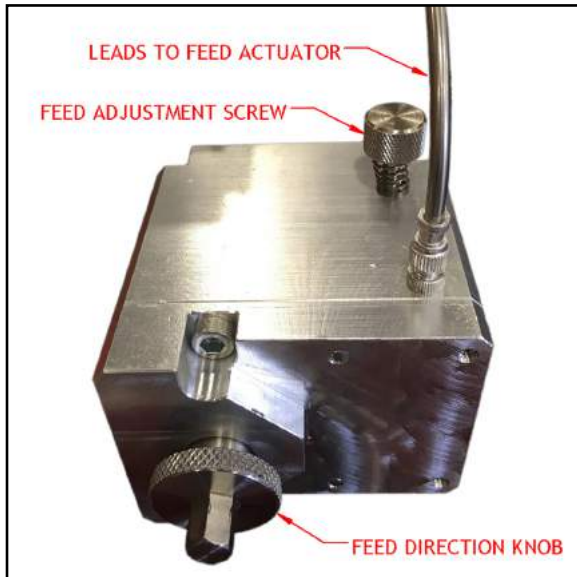
4.3.2 Anhalten der Maschine

Gehen Sie beim Anhalten der ODF60 Flanschdrehmaschine wie folgt vor:

1. Schalten Sie die Vorschubeinheiten aus (siehe Darstellung 3-9 auf Seite 20).
2. Schließen Sie das Ventil der GESCHWINDIGKEITSREGELUNG indem Sie das Rad im Uhrzeigersinn drehen.
3. Drücken Sie den Schieber für das DRUCKLUFT-ABSPERRVENTIL zum Schließen nach unten (wie es in Abbildung 4-3 zu sehen ist). Dadurch wird die restliche Druckluft aus dem Air Caddy-Kreislauf abgelassen.

4.3.3 Korrektur der Maschineneinstellung

Gehen Sie bei der manuellen Einstellung des Schneidwerkzeugs und dessen Position und Winkels wie folgt vor:

1. Schalten Sie die Vorschubeinheiten aus (siehe Abbildung 4-4).
2. Halten Sie die Maschine an und verriegeln Sie sie (siehe Abschnitt 4.3.2).
3. Stellen Sie die Position oder den Winkel des Schneidwerkzeugs manuell nach (siehe Abschnitt 3.4.1 auf Seite 18 und Abschnitt 3.4.2 auf Seite 19).

⚠️ WARNUNG

Versuchen Sie nicht, den Winkel des Schneidwerkzeugs manuell nachzustellen oder die Einstellungen der Vorschubeinheit zu verändern, während die Maschine in Betrieb ist. Sollten Sie die Einstellungen an der Vorschubeinheit mit der Hand oder mit Werkzeugen verändern, während die Maschine in Betrieb ist, kann das zu schweren Verletzungen führen.

5 WARTUNG

INHALT:

5.1 CHECKLISTE FÜR DIE WARTUNG - - - - -	27
5.2 ZUGELASSENE SCHMIERMITTEL - - - - -	27
5.3 WARTUNGSAUFGABEN - - - - -	28
5.3.1 PRÜFUNG DES ÖLTANKS UND DES BEHÄLTERS AM PARTIKELFILTER DES AIR CADDY - - - - -	28
5.3.2 PRÜFUNG DES AUSFALL-SIGNALKREISES AM AIR CADDY - - - - -	29
5.3.3 TEST DES NOT-HALT-SCHALTERS - - - - -	29
5.3.4 ZAPFEN-FÜHRUNGEN - - - - -	29
5.3.4.1 RADIALE ZAPFEN-FÜHRUNGEN - - - - -	29
5.3.4.2 AXIALE ZAPFEN-FÜHRUNGEN - - - - -	29
5.3.5 MONTAGE UND ENTFERNEN DER SCHUTZVORRICHTUNGEN - - - - -	29
5.3.6 WALZEN-EINSTELLUNG - - - - -	30
5.4 FEHLERBEHEBUNG - - - - -	31
5.4.1 DIE MASCHINE DREHT NICHT - - - - -	31
5.4.2 DER VORSCHUB FUNKTIONIERT NICHT - - - - -	31
5.4.3 DIE MASCHINE LIEFERT EIN SCHLECHTES ERGEBNIS - - - - -	31
5.4.4 DIE MASCHINE SCHNEIDET NICHT PLAN - - - - -	31

5.1 CHECKLISTE FÜR DIE WARTUNG

Tabelle 5-1 Aufstellung der Wartungsintervalle und -Aufgaben

TABELLE 5-1. WARTUNGSINTERVALLE UND -AUFGABEN

Intervall	Aufgabe	Bezug
Vor der Inbetriebnahme	Prüfen Sie den Stand im Öltank und im Behälter am Partikelfilter des Air Caddy	5.3.1
	Prüfen Sie die Druckluftleitungen auf Beschädigung und Abnutzung.	--
	Prüfen Sie den Zustand des Schneidwerkzeugs Falls nötig, tauschen Sie es aus.	5.4.3
	Prüfen Sie den Ausfall-Signalkreis am Air Caddy.	5.3.2
Vor und nach jedem Einsatz	Entfernen Sie Abfall, Öl und Feuchtigkeit von den Oberflächen der Maschine.	--
Nach jedem zehnten Betriebszyklus	Schmieren Sie die radialen und den axialen Zapfen-Führungen.	5.3.4

5.2 ZUGELASSENE SCHMIERMITTEL

H&S empfiehlt, die folgenden Schmiermittel an den hier angegebenen Schmierpunkten einzusetzen.

Der Einsatz von falschen Schmiermitteln kann die Maschine beschädigen oder zu vorzeitigem Verschleiß führen.

! VORSICHT

Vermeiden Sie eine Beschädigung oder den vorzeitigen Verschleiß und erhalten Sie die Garantie, indem Sie ausschließlich zugelassene Schmiermittel verwenden.

TABELLE 5-2. ZUGELASSENE SCHMIERMITTEL

Anwendungsbereich	Schmiermittel	Biologisch abbaubare Schmiermittel	Viskosität (cSt)	Menge	Häufigkeit
Täglich					
Rechtwinklige und Zapfen-Führungen ^a	Mobil Vactra Oil Heavy Medium	entfällt	>68 @ 40 °C	Nach Verbrauch	Täglicher Einsatz der Maschine
Bei jedem Einsatz					
Air Caddy	Unax AW 32	entfällt	22-68 @ 40 °C 4.3-8.7 @ 100 °C	Schmieröl-Behälter auffüllen	Bei jedem Einsatz
Unlackierte Oberflächen	LPS1 oder LPS2	entfällt	38 @ 25 °C	Nach Verbrauch	Bei jedem Einsatz, und vor der Lagerung
Wöchentlich					
Führungsschraube am Werkzeugkopf	NOOK E-100 spray lube NOOK PAG-1 grease	CASTROL BioTac EP 2	96 @ 40 °C 113 @ 100 °C	Leichte Beschichtung, Auftrag mit der Hand oder gesprüht	Wöchentlich während des Einsatzes der Maschine
Spannpratzen	Moly Grade Anti-Seize	entfällt	entfällt	1 cm ³ pro Schraube	Wöchentlich während des Einsatzes der Maschine und vor ihrer Lagerung
Jährlich					
Dichtungsfläche des Führungsrings	LPS All-Purpose Anti-Seize Platinum Grade	entfällt	entfällt	Nach Verbrauch	Wöchentlich während des Einsatzes der Maschine

a. Verwenden Sie hochwertiges raffiniertes mineralisches oder synthetisches Rostschutzöl, das einen starken Ölfilm bildet und nur schwer mit Kühlmitteln emulgiert oder davon abgewaschen wird. Allgemein sind Hydrauliköle nicht für die Schmierung von Schubwegen geeignet.

5.3 WARTUNGSAUFGABEN

Die einzelnen Aufgaben während der Wartung werden in den folgenden Abschnitten beschrieben.

5.3.1 Prüfung des Öltanks und des Behälters am Partikelfilter des Air Caddy

Prüfen Sie den Öltank und den Behälter am Partikelfilter des Air Caddy wie folgt:

1. Prüfen Sie den Stand im Öltank des Air Caddy am Sichtglas (siehe Abbildung 4-3 auf Seite 25). Falls nötig, füllen Sie Öl nach.

2. Prüfen Sie den Stand im Behälter am Partikelfilter des Air Caddy am Sichtglas. Falls nötig, entleeren Sie den Behälter.

5.3.2 Prüfung des Ausfall-Signalkreises am Air Caddy

Der Ausfall-Signalkreis am Air Caddy verhindert, dass die Maschine unerwartet neu startet, nachdem die Druckluftzufuhr zum Air Caddy zuvor unterbrochen worden ist und dann wieder einsetzt.

Prüfen den Ausfall-Signalkreis am Air Caddy wie folgt:

1. Prüfen Sie, ob der Air Caddy mit einer Druckluftquelle und der ODF60 Flanschdrehmaschine verbunden ist.
2. Prüfen sie, ob das Druckluft-Zufuhrventil offen ist (Schieber nach oben gezogen). Siehe Abbildung 4-3 auf Seite 25.
3. Drücken Sie den START-Taster.
4. Öffnen Sie das Geschwindigkeits-Einstellventil langsam, bis der Rotationsantrieb einsetzt.
5. Schließen sie das DRUCKLUFT-ABSPERRVENTIL (drücken Sie den Schieber herunter).
6. Prüfen Sie, ob die ODF60 Flanschdrehmaschine anhält.
7. Öffnen sie das DRUCKLUFT-ABSPERRVENTIL.
8. Prüfen Sie, ob die Maschine trotzdem nicht startet.

5.3.3 Test des Not-Halt-Schalters

Gehen Sie beim Anhalten der Maschine wie folgt vor:

1. Drücken Sie den NOT-HALT-Taster während die Maschine läuft.
2. Prüfen Sie, ob die Maschine anhält.
3. Setzen Sie die NOT-HALT-Funktion zurück, indem Sie Taster herausziehen.
4. Prüfen Sie, ob die Maschine erneut startet.

5.3.4 Zapfen-Führungen

5.3.4.1 Radiale Zapfen-Führungen

Gehen Sie bei der Wartung der Zapfen-Führungen wie folgt vor:

1. Drehen Sie an der Schraube des radialen Vorschubs am Schlitten und bewegen Sie damit den Werkzeugkopf an ein Ende des radialen Vorschubweges.
2. Wischen Sie die freiliegenden Zapfen-Führungen sauber und schmieren sie sie mit „Mobil VACTRA

medium heavy way oil“ oder einem gleichwertigen Öl.

3. Bewegen Sie den Schlitten mit dem Werkzeugkopf an das andere Ende des radialen Vorschubweges.
4. Wischen Sie die restlichen freiliegenden Zapfen-Führungen sauber und schmieren sie sie mit „Mobil VACTRA medium heavy way oil“ oder einem gleichwertigen Öl.

5.3.4.2 Axiale Zapfen-Führungen

Gehen Sie bei der Wartung der axialen Zapfen-Führungen wie folgt vor:

1. Drehen Sie an der Schraube des axialen Vorschubs am Schlitten und bewegen Sie damit den Werkzeugkopf an ein Ende des axialen Vorschubweges.
2. Wischen Sie die freiliegenden Zapfen-Führungen sauber und schmieren sie sie mit „Mobil VACTRA medium heavy way oil“ oder einem gleichwertigen Öl.
3. Bewegen Sie den Schlitten mit dem Werkzeugkopf an das andere Ende des axialen Vorschubweges.
4. Wischen Sie die restlichen freiliegenden Zapfen-Führungen sauber und schmieren Sie sie mit „Mobil VACTRA medium heavy way oil“ oder einem gleichwertigen Öl.

5.3.5 Montage und Entfernen der Schutzvorrichtungen

Gehen Sie bei der Wartung der Maschine zum Abbauen der Schutzvorrichtungen wie folgt vor:

1. Drehen Sie alle M8-Schrauben so weit heraus, dass sie ein Stück hervorstehen.
2. Suchen Sie eine der mittleren M8-Schrauben der Abschnitte in der Schutzvorrichtung heraus.
3. Setzen Sie einen 9/16er Ringschlüssel so hinter dem Schraubenkopf an, dass er als Hebel gegen die Schutzvorrichtung drückt.



ABBILDUNG 5-1. RINGSCHLÜSSEL HINTER DEM SCHRAUBENKOPF

4. Ziehen Sie die Schraube kurz nach oben und entfernen sie die Schutzvorrichtung.
5. Wiederholen Sie diesen Schritt 2 bei Schritt 4 den restlichen Abschnitten.

Nach erfolgter Wartung, gehen Sie wie folgt vor, um die Schutzvorrichtung wieder zu installieren:

1. Falls sie sich noch dort befinden, entfernen Sie alle M8-Schrauben von den Abschnitten der Schutzvorrichtung.
2. Setzen Sie den ersten Abschnitt der Schutzvorrichtung an seine Stelle an der Maschine.
3. Stecken Sie in der Mitte der Schutzvorrichtung zwei 3/16“ Dorne (oder Ähnliches) in die Bohrungen in der Schutzvorrichtung und die dahinterliegende Gewindebohrung. Bei größeren Maschinen kann es notwendig sein, an einem Ende zu beginnen, anstatt in der Mitte.



ABBILDUNG 5-2. DORN ALS HILFE BEI DER MONTAGE DER SCHUTZVORRICHTUNG

4. Hebeln Sie die Dorne in Richtung der Mitte der Maschine, damit ziehen Sie sie in die richtige Position. Gleichzeitig schlagen Sie mit einem Gummihammer auf die Oberfläche der Schutzvorrichtung.
5. Wiederholen Sie die Schritte 2-4 bei den restlichen Abschnitten.
6. Drehen Sie dann die M8-Schrauben wieder ein.

5.3.6 Walzen-Einstellung

Während die Maschine in Betrieb ist, sollte jede Walze ungefähr zwei Drittel der Zeit in Bewegung sein. Wenn die Walzen zu fest eingestellt sind, ist die Maschine schwergängig. Bei einer idealen Einstellung der Walzen lässt sich die Maschine mit der Hand drehen.

! WARNUNG

Das Einstellen der Walzen erfordert, dass die Maschine ohne Schutzvorrichtung in Betrieb ist. Versuchen Sie niemals, die Walzen einzustellen, während die Maschine dreht, das kann zu schweren Verletzungen oder zum Tode führen.

Nehmen Sie die folgenden Einstellungen an den Walzen vor:

1. Entfernen Sie alle Schutzvorrichtungen. (Siehe Abschnitt 5.3.5 auf Seite 29.)
2. Starten Sie die Maschine und fahren Sie sie auf die volle Betriebsgeschwindigkeit hoch.
3. Beobachten Sie, welche Walzen nicht richtig drehen.
4. Halten Sie die Maschine an und drücken Sie das Druckluft-Absperrventil nach unten.
5. Setzen Sie den Einstellschlüssel (siehe Abbildung 5-3) an der Excenter-Buchse an und lösen Sie die Feststellschraube mit einem 5/16“ Inbusschlüssel. Stellen Sie die Excenter-Buchse so ein, dass die Walze gerade die Fuge im Führungsring berührt.

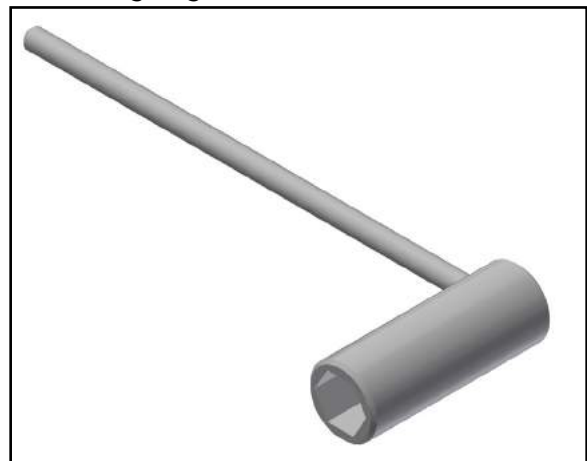

FIGURE 5-3. WALZEN-EINSTELLSPANNER (P/N 86988)

6. Ziehen Sie die Feststellschraube an, während Sie die Stellung der Excenter-Buchse mit dem Einstellschlüssel fixieren.

7. Testen Sie die Maschine erneut bei voller Betriebsgeschwindigkeit.
8. Tragen Sie „Anti-Seize“ auf die Dichtungsoberfläche des Führungsringes und die Walzen, wie es in Abbildung 5-2 zu sehen ist.
9. Montieren Sie wieder alle Schutzvorrichtungen.

5.4 FEHLERBEHEBUNG

In diesem Abschnitt gibt es Hinweise auf Lösungswege bei einfachen Problemen mit der Maschine. Bei einem komplexeren Wartungsbedarf oder Fragen zu den hier folgend aufgezeigten Vorgehensweisen, setzen Sie sich bitte mit H&S in Verbindung.

5.4.1 Die Maschine dreht nicht

Wenn die Maschine nicht dreht, prüfen Sie zunächst wie folgt:

1. Die Kraftquelle ist angeschlossen und auch aufgeladen.
2. Der NOT-HALT ist zurückgesetzt (Abschnitt 4.3.1 auf Seite 25 und Abschnitt 5.3.3 auf Seite 29).
3. Die Druckluftzufuhr ist geöffnet und nicht beschädigt (Abbildung 4-3 auf Seite 25).
4. Druckluft steht am Air Caddy an und wird auch weitergeleitet. Prüfen Sie die Druckluft, indem Sie den Schlauch an den Schnellanschlüssen abkoppeln und prüfen, ob Druckluft entweicht (Abbildung 4-3 auf Seite 25).
5. Alle Ventile sind offen (Abbildung 4-3 auf Seite 25).
6. Alle Schnellanschlüsse sind komplett belegt (Abbildung 4-3 auf Seite 25).
7. Prüfen Sie die Bewegung der Maschine, stellen Sie aber vorher sicher, dass die Stromversorgung des Maschinenantriebs abgekoppelt und ausgeschaltet ist, dann drehen Sie die Maschine per Hand und greifen dabei die Griffe an der Brücke.

5.4.2 Der Vorschub funktioniert nicht

Wenn der Vorschub der Maschine nicht ordnungsgemäß funktioniert, prüfen Sie wie folgt:

1. Alle Vorschubeinheiten sind eingeschaltet (Abschnitt 3.4.4 auf Seite 20).
2. Der Knopf für die Festlegung der Vorschubrichtung ist hineingedrückt oder herausgezogen, und steht nicht in der Mitte, der Leerlaufposition.

5.4.3 Die Maschine liefert ein schlechtes Ergebnis

Wenn die Maschine ein schlechtes Ergebnis liefert, prüfen Sie wie folgt:

1. Das Werkzeug ist korrekt installiert (Abschnitt 3.4.2 auf Seite 19).
2. Die Maschine ist dicht am Werkstück montiert (Abschnitt 3.3 auf Seite 15).
3. Die Schrauben der Brücke sind gesichert.
4. Die Befestigungsschrauben an der radialen und der axialen Stelleiste sind korrekt eingestellt (Abschnitt 4.2.1 auf Seite 23 und Abschnitt 4.2.2 auf Seite 24).
5. Die Klemmschrauben für den Schwenkwinkel am rotierenden Werkzeugkopf sind angezogen (Abschnitt 3.4.1 auf Seite 18).
6. Das Schneidewerkzeug oder der Einsatz ist scharf und hat die richtige Geometrie für die Art des Materials und der Bearbeitung.
7. Die Geschwindigkeits- und die Nachführwerte sind korrekt eingegeben. Wenn nötig, versuchen Sie andere Geschwindigkeits- oder Vorschubeinstellungen. Normalerweise verursachen geringere Geschwindigkeiten und flachere Schnitte geringere Vibrationen am Werkzeug.

5.4.4 Die Maschine schneidet nicht plan

Wenn die Maschine nicht plan schneidet, gehen Sie wie folgt vor:

1. Bevor Sie einen kritischen Abschluss-Vorgang durchführen, lassen Sie die Maschine wenigstens 15 Minuten lang andauernd drehen, um sicher zu sein, dass sie die richtige Betriebstemperatur erreicht hat.
2. Überprüfen Sie die Einstellung der Maschine (Abschnitt 3.4.1 auf Seite 18).
3. Verschieben Sie den Werkzeughalter so weit wie nötig zur Flansch (Abschnitt 3.4.1 auf Seite 18).

Diese Seite bleibt absichtlich unbeschriftet

6 LAGERUNG UND TRANSPORT

INHALT:

6.1 LAGERUNG	33
6.1.1 KURZFRISTIGE LAGERUNG	33
6.1.2 LANGFRISTIGE LAGERUNG	33
6.2 TRANSPORT	34
6.3 ENTSORGUNG	34

6.1 LAGERUNG

WARNUNG

Wenn sie nicht ordnungsgemäß gesichert ist, kann diese Maschine herunterfallen und lebensgefährliche Verletzungen beim Personal verursachen. Bei der Montage an senkrechten Flanschen und bei der Überkopf-Montage müssen Sie besonders aufmerksam sein.

Die Maschine muss ordnungsgemäß angeschlagen und an einem Kran oder einem anderen geeigneten Hebezeug aufgehängt sein, bevor irgendein Arbeitsschritt ihrer Demontage begonnen wird.

Eine ordentliche Lagerung der ODF60 Flanschdrehmaschine verlängert die Lebensdauer und schützt vor Beschädigung.

Vor der Lagerung müssen folgende Schritte unternommen werden:

1. Reinigen Sie die Maschine mit Lösungsmitteln von Fetten, Metallspänen und Feuchtigkeit.
2. Entfernen Sie alle Flüssigkeiten aus dem Druckluftantrieb.

Lagern Sie die ODF60 Flanschdrehmaschine in ihrem Transportbehälter. Bewahren Sie das gesamte Verpackungsmaterial für das erneute Verpacken der Maschine auf.

6.1.1 Kurzfristige Lagerung

Beim kurzfristigen Lagern (drei Monate oder weniger), gehen Sie wie folgt vor:

1. Ziehen Sie das Werkzeug vom Werkstück ab.
2. Entfernen Sie alle Werkzeuge.

3. Entkoppeln Sie alle Schlauchverbindungen.
4. Entfernen Sie die Maschine vom Werkstück.
5. Reinigen Sie die Maschine von Schmutz, Fetten, Metallspänen und Feuchtigkeit.
6. Sprühen Sie alle unlackierten Oberflächen mit LPS-2-Rostschutz ein.
7. Lagern Sie die ODF60 Flanschdrehmaschine in ihrem Original-Transportbehälter (siehe Abbildung 6-1).

6.1.2 Langfristige Lagerung

Beim langfristigen Lagern (länger als drei Monate), gehen Sie wie folgt vor:

1. Gehen Sie wie bei der kurzfristigen Lagerung vor, aber benutzen Sie als Rostschutz LPS-3 statt LPS-2.
2. Geben Sie auch ein Entfeuchterkissen in dem Behälter. Legen Sie die Maschine gemäß der Anweisungen des Herstellers in den Behälter.
3. Lagern Sie den Transportbehälter an einem Ort, der vor direkter Sonneneinstrahlung geschützt ist und bei einer Temperatur unter 70°F (21°C) und einer Luftfeuchtigkeit unter 50%.

6.2 TRANSPORT

Die ODF60 Flanschdrehmaschine kann in ihrem original Transportbehälter transportiert werden, wie es in Abbildung 6-1. gezeigt wird.



ABBILDUNG 6-1. ODF60 TRANSPORTKISTE

6.3 ENTSORGUNG

Für die Entsorgung der ODF60 Flanschdrehmaschine bauen Sie den Antrieb ab und verarbeiten ihn getrennt von den restlichen Bestandteilen der Maschine. Lesen Sie Anhang A für Informationen über den Zusammenbau der Komponenten.

ANHANG A MONTAGEZEICHNUNGEN

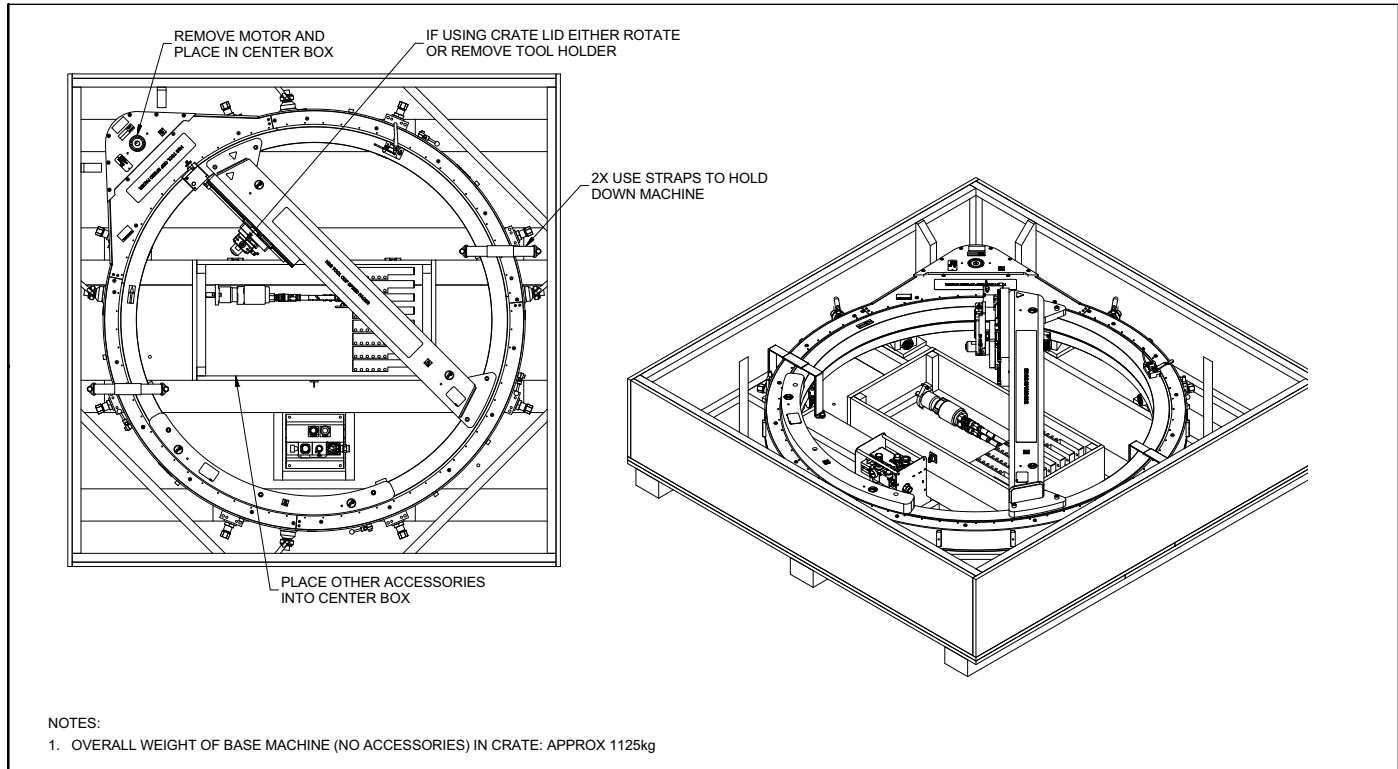
Liste der Zeichnungen

ABBILDUNG A-1. ODF60 FLANSCHENDREHMASCHINE ASSEMBLY (P/N 86990) - - - - -	36
ABBILDUNG A-2. ODF60 FLANSCHENDREHMASCHINE LABELS ASSEMBLY (P/N 86990) - - - - -	37
ABBILDUNG A-3. ODF60 FLANSCHENDREHMASCHINE PARTS LIST (P/N 86990) - - - - -	38
ABBILDUNG A-4. MONTAGE DES SCHIEBEWERKZEUGHALTERS (P/N 79790) - - - - -	39
ABBILDUNG A-5. TEILELISTE DES SCHIEBEWERKZEUGHALTERS (P/N 79790) - - - - -	40
ABBILDUNG A-6. MONTAGE DES DRUCKLUFTANTRIEBS (P/N 83430) - - - - -	41
ABBILDUNG A-7. MONTAGE DES DRUCKLUFTANTRIEBS (P/N 83430) - - - - -	42
ABBILDUNG A-8. MONTAGE DES JUSTIERFUSSES (P/N 86880) - - - - -	43
ABBILDUNG A-9. MONTAGE DER RADIALEN ACHSE (P/N 86890) - - - - -	44
ABBILDUNG A-10. TEILELISTE DER RADIALEN ACHSE (P/N 86890) - - - - -	45
ABBILDUNG A-11. MONTAGE DES ZUGSEIL-VORSCHUBKASTENS (P/N 86900) - - - - -	46
ABBILDUNG A-12. MONTAGE SCHALTERS IM ZUGSEIL-VORSCHUBKASTEN (P/N 86900) - - - - -	47
ABBILDUNG A-13. MONTAGE DER VORSCHUBEIHEIT (P/N 86910) - - - - -	48
ABBILDUNG A-14. ZUSAMMENBAU SPANNFUß (P/N 86970) - - - - -	49
ABBILDUNG A-15. MONTAGE DES ANTRIEBSMOTORS (P/N 86989) - - - - -	50
ABBILDUNG A-16. MONTAGE DES BEFESTIGUNGSSATZES (P/N 87164) - - - - -	51
ABBILDUNG A-17. MONTAGE DES RÜCKSEITEN-MONTAGESATZES (P/N 87310) - - - - -	52
TABELLE A-1. WERKZEUGSATZ P/N 78530 - - - - -	53



ABBILDUNG A-1. ODF60 FLANSCHDREHMASCHINE ASSEMBLY (P/N 86990)



ABBILDUNG A-2. ODF60 FLANSCHENDREHMASCHINE LABELS ASSEMBLY (P/N 86990)

PARTS LIST			PARTS LIST				
ITEM	QTY	P/N:	DESCRIPTION	ITEM	QTY	P/N:	DESCRIPTION
1	2	10445	FTG PLUG 1/4 NPTM SOCKET	28	34	86878	ROLLER W4
2	2	10453	SCREW 3/8-16 X 1-1/4 SHCS	29	34	86879	BUSHING ECCENTRIC SIZE 4
3	34	10557	SCREW 3/8-16 X 2 SHCS	30	4	86880	ASSY JACKING FOOT LEVELING
4	14	10588	SCREW DRIVE #2 x 1/4 HOLE SIZE .089	31	16	86887	POST 17MM HEX X 72MM M8 X 1.25 TAPPED AND THRD EACH END
5	1	15079	WASHER THRUST 1.000 ID X 1.562 OD X .030	32	1	86889	IDLER TAKE UP ODF DRIVE
6	2	16111	BRG BALL 1.7717 ID X 2.9528 OD X .6299 SEALS	33	1	86890	ASSY RADIAL AXIS 356MM TRAVEL
7	34	19236	WASHER 3/8 FLTW/HARDENED	34	1	86894	SHEAVE SIZE B 2 GROOVE 8.35 OD QD BORE
8	1	20956	BLOCK ADJUSTING	35	1	86897	RING SNAP 1.937 OD X .031 SINGLE TURN SPIRAL
9	4	22814	RING HOIST 3/4-10 X 1-1/2 5000 LB	36	1	86900	ASSY FEEDBOX PULL CABLE
10	3	29152	PLATE MASS CE	37	192	86901	SEAL STRIP .062" THICK X 3/8" WIDE
11	1	30207	SCREW M12 X 1.75 X 35mm SHCS	38	4	86910	ASSY FEED TRIPPER
12	7	35215	SCREW M12 X 1.75 X 40mm SHCS	39	4	86970	ASSY JACKING FOOT NON-LEVELING
13	6	50458	SCREW M8 X 1.25 X 20mm SHCS	40	1	86972	SHAFT ODF DRIVE
14	8	59039	LABEL WARNING LIFT POINT ROUND 1.5"	41	1	86989	ASSY ODF DRIVE MOTOR
15	1	59042	LABEL WARNING - HAND CRUSH/MOVING PARTS	42	1	86991	FRAME WELDMENT SF60
16	1	60219	LABEL HOSE CONNECT SCHEME RED-RED/BLUE-BLUE	43	1	86992	RING TRACK SF60
17	1	60220	LABEL HOSE CONNECT SCHEME BLUE-RED/RED-BLUE	44	1	86993	GUARD AND SEAL ASSY SF60
18	1	62978	WASHER M12 FLTW 27MM OD 3.1 MM THICK	45	2	86994	BELT V B225
19	2	67743	RING SNAP 2.0 ID X .062 TH	46	1	86996	COUNTERWEIGHT SF60
20	2	67910	BRG BALL 1.000 ID X 2.000 OD X .500 2 SEALS	47	1	86997	WELDMENT BRIDGE ODF60
21	1	78530	(NOT SHOWN) TOOL KIT SF SERIES	48	1	86998	PLATE TAKE UP ODF DRIVE
22	1	79324	LABEL WARNING - HAND ENTANGLEMENT/ROTATING GEARS 1.13 TALL TRIANGLE YELLOW	49	1	86999	PLATE COVER DRIVE SF60
23	2	79385	LABEL WARNING - LIFT SUB ASSY ONLY GRAPHIC 2 X 3	50	1	87008	BUSHING QD SK 1-15/16
24	1	79635	SCREW 3/4-10 X 4 SSSFP	51	24	87020	SCREW M8 X 1.25 X 15MM BHCS CAPTIVE 10 THD STAINLESS
25	1	79790	ASSY SLIDE TOOL HOLDER	52	1	87022	SCREW 1 DIA X 1.5 X 3/4-10 SHLDCS
26	1	83430	(NOT SHOWN) PNEUMATIC CONDITIONING UNIT WSHEET METAL STAND	53	1	87220	(NOT SHOWN) CRATE ODF60 84 X 84 X 21-1/4 3/4 PLY
27	2	84856	LABEL DANGER - ODF TETHER MACHINE BEFORE USE	54	1	87261	LABEL H&S ODF60 LOGO 3.5 X 33.0
				55	1	87265	LABEL ARROW BLK/YEL 1" X 3"
				56	1	87269	PLATE SERIAL YEAR MODEL BLANK CE 1.5 X 3.0
				57	1	87271	LABEL WARNING - EYE EAR MANUAL PROTECTION 1-3/8 X 2-3/4
				58	1	87272	LABEL MADE IN THE U.S.A 1.5" X 2.5"
				59	1	87429	LABEL H&S ODF40 LOGO 3.0 X 14.0

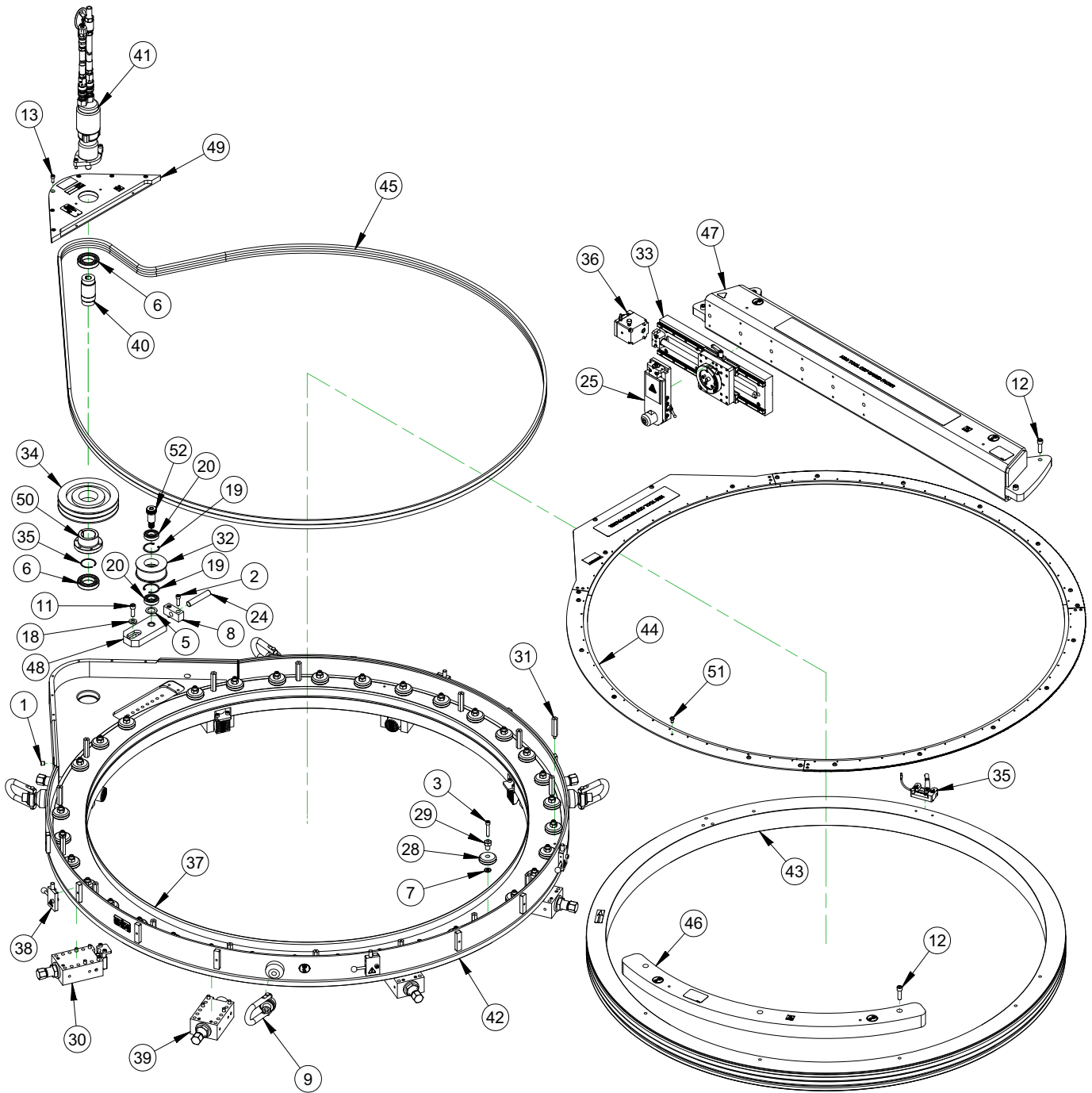
ABBILDUNG A-3. ODF60 FLANSCHENDREHMASCHINE PARTS LIST (P/N 86990)

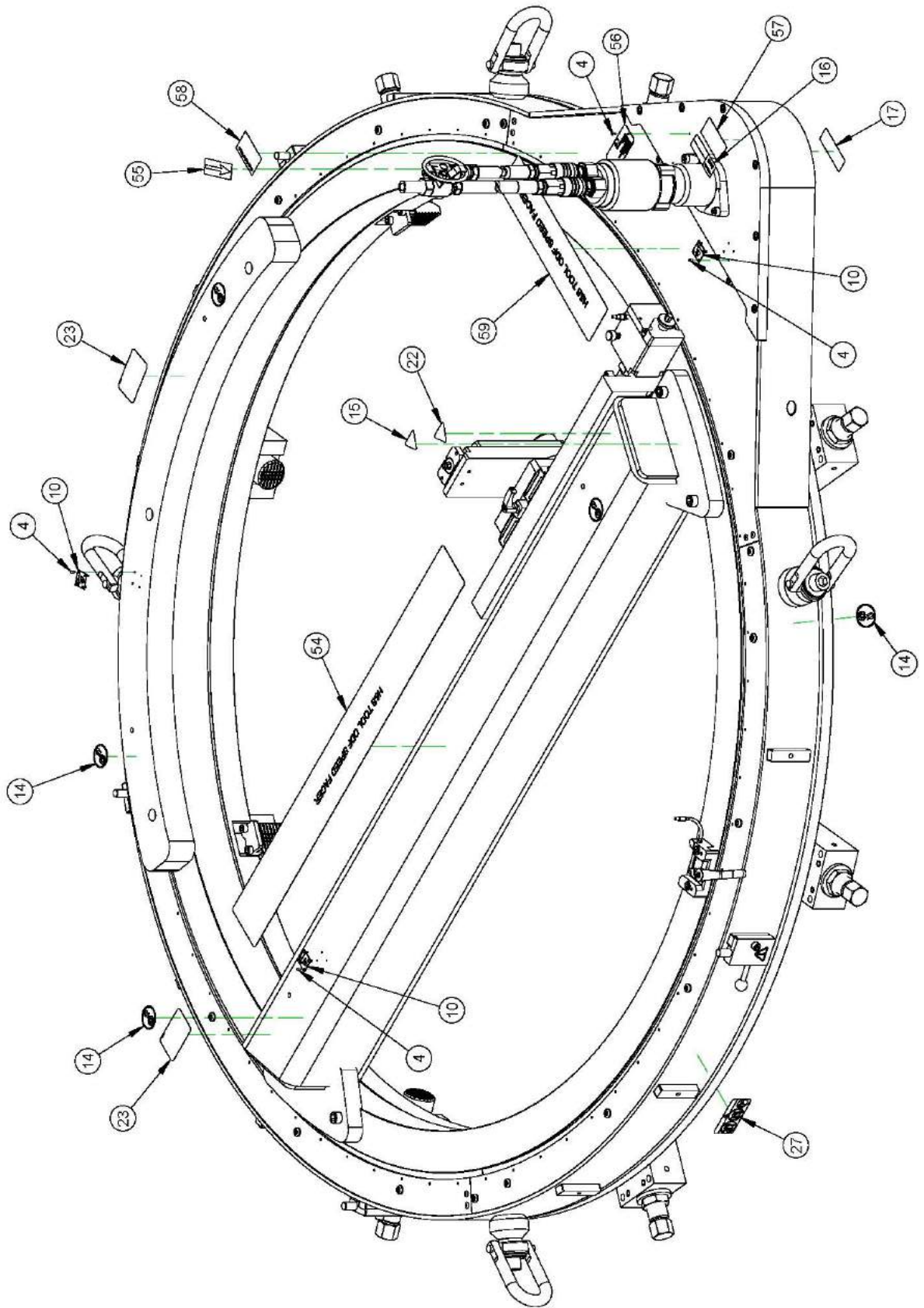

ABBILDUNG A-4. MONTAGE DES SCHIEBEWERKZEUGHALTERS (P/N 79790)

PARTS LIST			
ITEM	QTY	P/N:	DESCRIPTION
1	4	10436	WASHER THRUST .500 ID X .937 OD X .060
2	2	10437	BRG THRUST .500 ID X .937 OD X .0781
3	2	16953	PIN DOWEL 3/16 DIA X 5/8
4	4	20772	NUT M6 X 1.0 STDN ZINC PLATED
5	4	35014	SCREW M6 X 1.0 X 16mm SHCS
6	2	35505	SCREW M6 X 1.0 X 30 SHCS
7	2	43489	BALL NYLON 1/8 DIA
8	1	45034	SCREW M6 X 1.0 X 12MM SSSDPPL
9	1	46902	LABEL WARNING HOT SURFACE GRAPHIC 1.13" TALL
10	1	48526	NUT LEADSCREW ACME 3/4-10 BRONZE LH
11	2	53365	SCREW M4 X 0.7 X 4 mm SSSFP
12	1	57214	BRG RETAINING NUT AXIAL FEED LEADSCREW
13	2	57320	RING O 1/16 X 13/16 ID X 15/16 OD
14	1	57793	BEARING BLOCK LEADSCREW
15	1	57912	LEAD SCREW AXIAL FEED FF LINE
16	1	58133	HANDLE ADJUSTABLE M6 X 1 X 20MM
17	2	59003	SCREW M6 X 1.0 X 14MM SHCS
18	4	74658	SCREW M6 X 1 X 25MM SSSDP
19	1	79548	BASE TOOL HOLDER
20	1	79826	PLATE DOVE CIRCULAR
21	1	80307	TOOL HEAD TOP SLIDE
22	1	80309	CLAMP TOOL BIT 3/4 SQ
23	AR	80419	(NOT SHOWN) SHIM 1.8 ID X 3.2 OD .001 THICK
24	AR	80420	(NOT SHOWN) SHIM 1.8 ID X 3.2 OD .002 THICK
25	AR	80421	(NOT SHOWN) SHIM 1.8 ID X 3.2 OD .005 THICK
26	1	82224	GIB TOOLHEAD
27	1	82280	SCREW M20 X 2.5 X 25MM SSSDP

ABBILDUNG A-5. TEILELISTE DES SCHIEBEWERKZEUGHALTERS (P/N 79790)

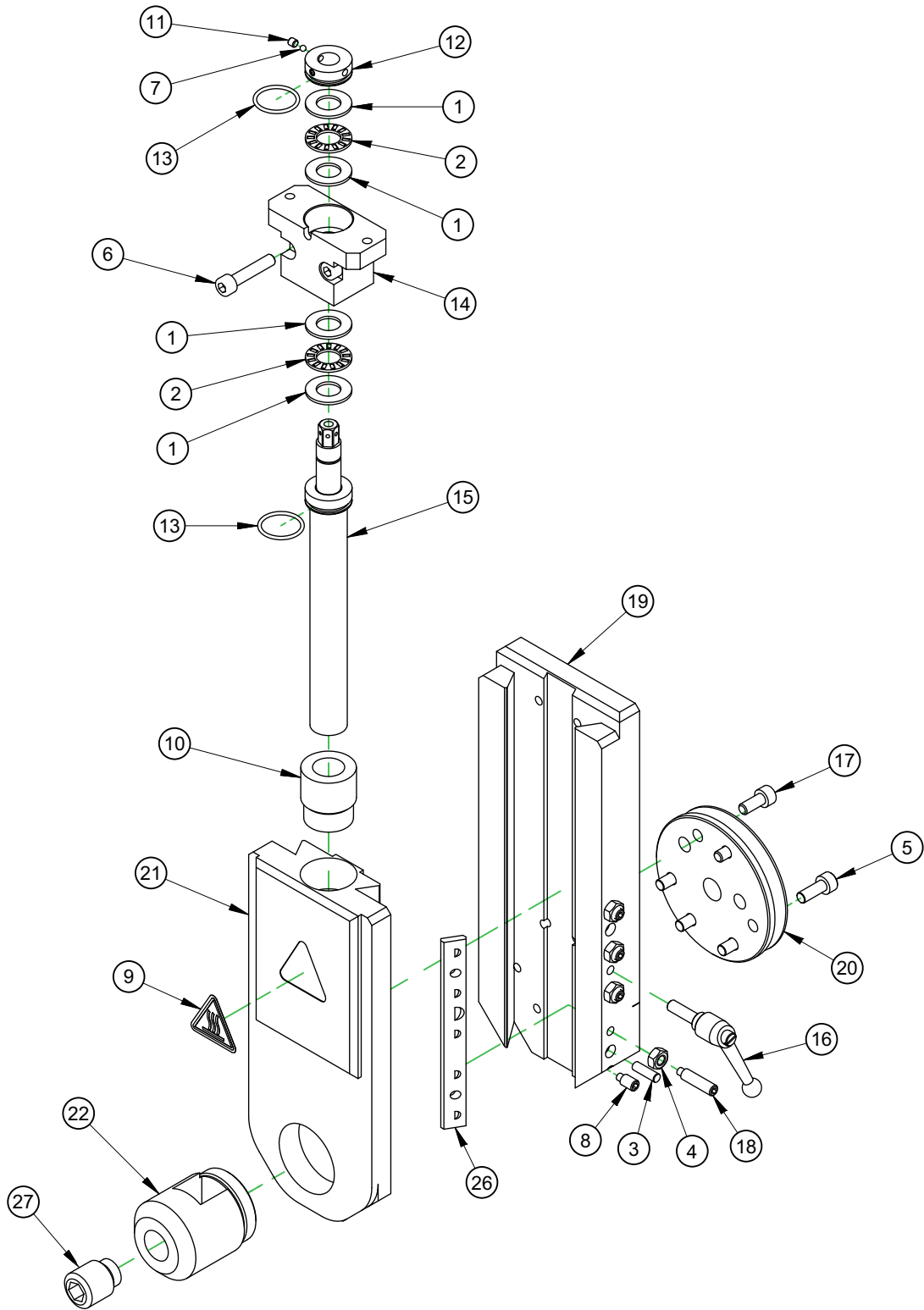

ABBILDUNG A-6. MONTAGE DES DRUCKLUFTANTRIEBS (P/N 83430)

PARTS LIST			
ITEM	QTY	P/N:	DESCRIPTION
1	1	10223	FTG NIPPLE CLOSE 1/2 NPTM X 1/2 NPTM 125 PSI 1-1/8 LONG
2	1	10319	FTG COUPLING 1/2 NPTF X 1/2 NPTF STEEL ZINC PLATED
3	4	11315	WASHER #10 FLTW BLACK OXIDE
4	1	14726	SCREW 10-32 X 1/4 SHCS
5	5	22235	FTG BARB #10-32 X 1/8 HOSE
6	1	40588	GROMMET 5/8 OD 5/16 ID
7	1	46768	LUBRICATOR AIR 1/2 NPTF 3.8OZ BOWL W/SIGHT
8	1	46769	VALVE EXHAUST QUICK PILOT 1/2NPTF MUFFLER
9	1	46777	VALVE SHUT OFF VS22 SERIES
10	2	46785	VALVE PUSHBUTTON 5 PORT PNEUMATIC
11	1	46797	LEGEND PLATE START 10250 SERIES
12	3	48648	FTG ELBOW 1/8 NPTM X 1/4 TUBE PRESTOLOK
13	28	48650	(NOT SHOWN) TUBING 1/4 OD POLYURETHANE
14	6	53617	SCREW M5 X 0.8 X 12MM BHCS BLACK FINISH
15	4	56357	SCREW 10-24 X 2.5 SHCS
16	3	59442	RING O 2mm X 23mm ID X 25mm OD
17	1	59458	PUSHBUTTON GREEN FLUSH
18	1	59459	PUSH BUTTON PUSH PULL MAINTAINED (M-M)
19	1	59462	PUSH BUTTON OPERATOR RED 1-5/8
20	1	59825	LEGEND PLATE STOP 10250SERIES YELLOW BACKGROUND
21	1	78054	FILTER/REGULATOR PARTICULATE 1/2NPTF METAL BOWL GLASS
22	1	81132	LABEL WARNING - INSERT SAFETY LOCK
23	4	83462	RUBBER BUMPER, 9/16 DIA X 1/8 TALL
24	1	83486	PRESSURE GAUGE, 0-160 PSI, 1/8 NPT CENTER BACK MOUNT
25	1	87223	STAND PCU
26	4	87533	NUT 10-24 STDNYLOC SS

ABBILDUNG A-7. MONTAGE DES DRUCKLUFTANTRIEBS (P/N 83430)

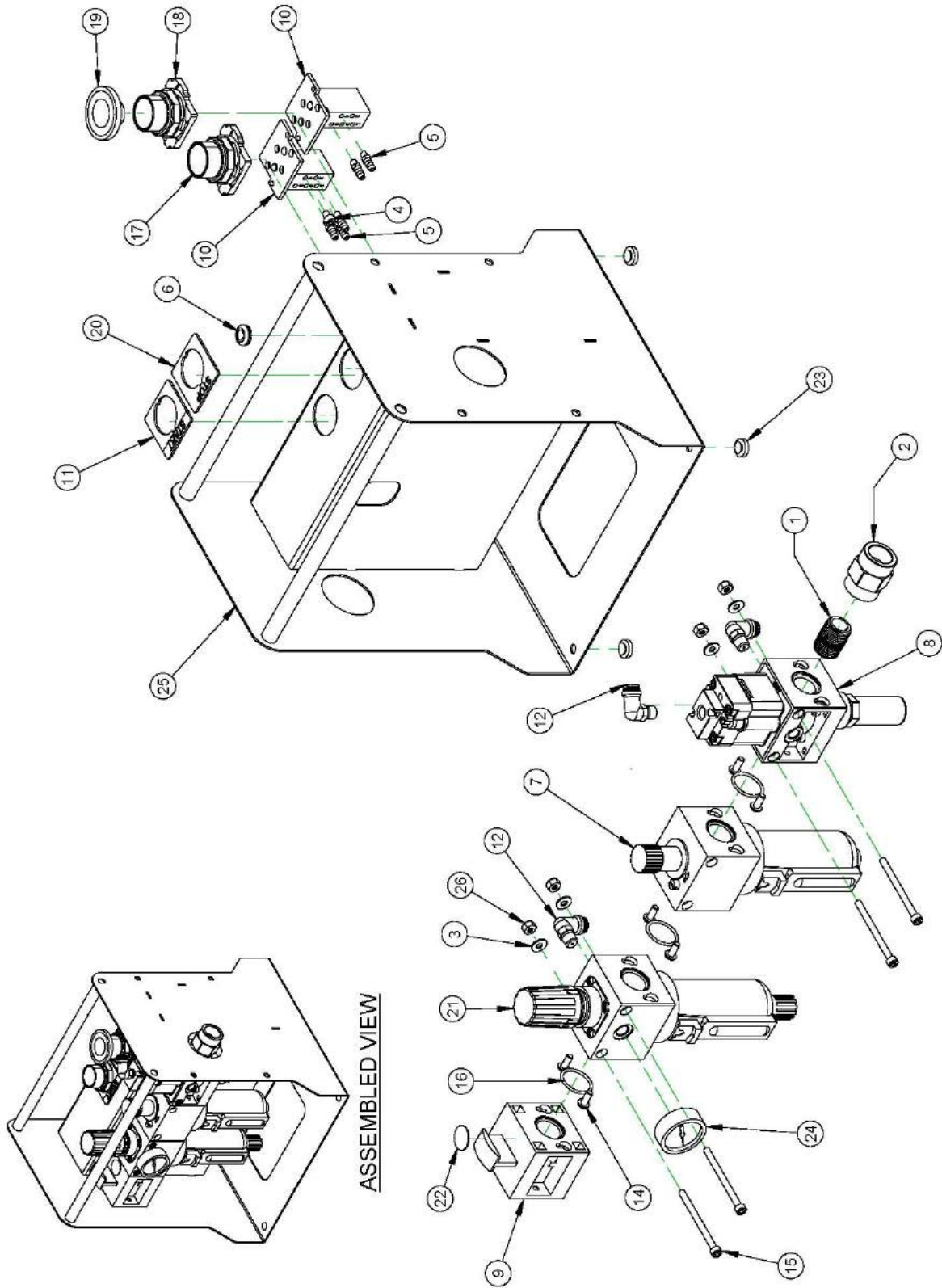
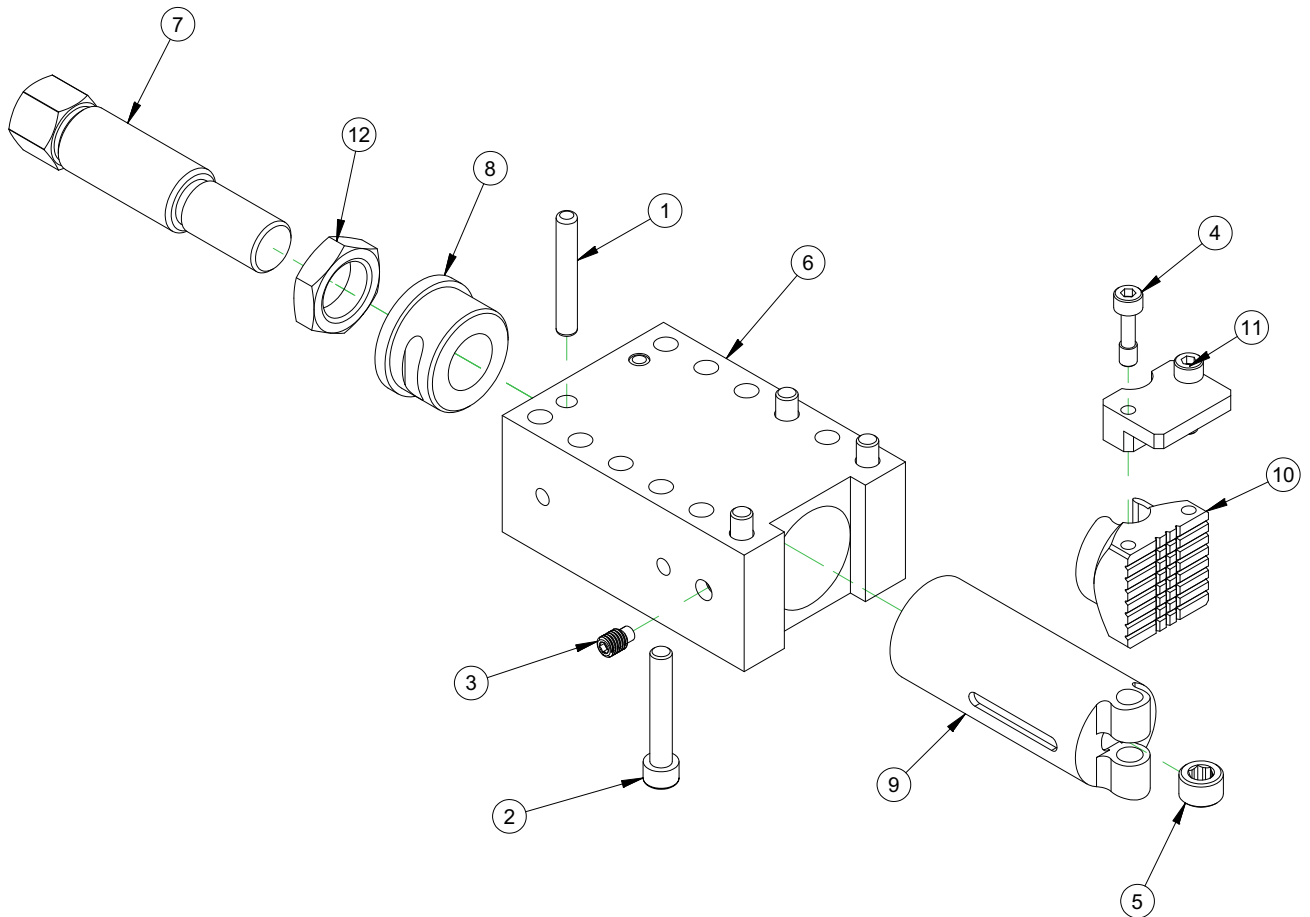

PARTS LIST			
ITEM	QTY	P/N:	DESCRIPTION
1	2	14297	PIN DOWEL 3/8 DIA X 2-1/2
2	4	45754	SCREW M10 x 1.5 x 60mm SHCS
3	1	48998	SCREW M10 X 1.5 X 16mm SSSHDP
4	2	74632	SCREW M8 X 1.25 X 30 OAL X 10 THD L STAINLESS
5	1	80430	SCREW MODIFIED M20 X 1.5 X 12.7MM HOLLOW LOCK
6	1	86881	HOUSING JACKING FOOT
7	1	86882	SCREW JACKING FOOT
8	1	86883	BUSHING THD 1-1/4-7
9	1	86884	RAM JACKING LEVELING
10	1	86885	JAW JACKING LEVELING
11	1	86886	SETUP FINGER
12	1	86908	NUT 1-1/4-7 JAMN 1/2 THICK

ABBILDUNG A-8. MONTAGE DES JUSTIERFUSSSES (P/N 86880)



ABBILDUNG A-9. MONTAGE DER RADIALEN ACHSE (P/N 86890)

PARTS LIST			
ITEM	QTY	P/N:	DESCRIPTION
1	4	10436	WASHER THRUST .500 ID X .937 OD X .060
2	2	10437	BRG THRUST .500 ID X .937 OD X .0781
3	1	11729	PIN DOWEL 1/4 DIA X 3/4
4	3	20398	PIN DOWEL 1/2 DIA X 1
5	20	22572	SCREW M4 X 0.7 X 25mm SHCS
6	2	33777	RING SNAP 1-3/16 ID (30MM)
7	10	35014	SCREW M6 X 1.0 X 16mm SHCS
8	2	35505	SCREW M6 X 1.0 X 30 SHCS
9	1	36087	SCREW M8 X 1.25 X 6MM SSSFP
10	18	38061	SCREW M4 X 0.7 X 20 SHCS
11	2	43489	BALL NYLON 1/8 DIA
12	2	53365	SCREW M4 X 0.7 X 4 mm SSSFP
13	1	57214	BRG RETAINING NUT AXIAL FEED LEADSCREW
14	2	57320	RING O 1/16 X 13/16 ID X 15/16 OD
15	8	61225	SCREW M8 X 1.25 X 40MM SHCS
16	1	62321	HOLDER FELT WIPER MILLING HEAD
17	6	62376	WASHER SPRING BELLEVILLE 1/8 ID X 1/4 OD X .013 THK
18	4	62379	SEAL FELT 16MM BALL SCREW 1.015 OD MILLING HEAD
19	1	62423	MOUNT BALL NUT MILLING HEAD
20	2	62903	WASHER SHIM .75 ID 1.125 OD .062 THICK STEEL
21	2	62909	SCREW 6MM DIA X 12MM X M5 X 0.8 SHLDCS
22	1	62960	BALL SCREW NUT 20MM X 5MM LEAD LEFT HAND 33 MM OD EICHENBERGER ROUND
23	18	68500	CAP RAIL 15MM METAL THK SHS
24	1	72636	ZIMMER BRAKE 15MM RAIL
25	1	72637	ZIMMER ADAPTER 15MM RAIL
26	2	72753	SCREW M8 X 1.25 X 50MM SHCS
27	1	79793	CLAMP COLLAR
28	1	79826	PLATE DOVE CIRCULAR
29	AR	80419	(NOT SHOWN) SHIM 1.8 ID X 3.2 OD .001 THICK
30	AR	80420	(NOT SHOWN) SHIM 1.8 ID X 3.2 OD .002 THICK
31	AR	80421	(NOT SHOWN) SHIM 1.8 ID X 3.2 OD .005 THICK
32	2	82226	COLLAR 8MM ID X 12MM OD X 25MM
33	2	86891	SLIDE RAIL THK SHS15 520MM LG PRELOADED METAL SCRAPERS 2 SHORT BLOCKS
34	1	86892	PLATE RADIAL SADDLE
35	1	86895	BALL SCREW 20MM DIA SF RADIAL AXIS
36	1	86896	PLATE RADIAL AXIS BASE
37	1	86898	BEARING BLOCK BALLSCREW
38	1	87033	PAD POLYURETHANE 1/4 DIA X .08 THICK

ABBILDUNG A-10. TEILELISTE DER RADIALEN ACHSE (P/N 86890)

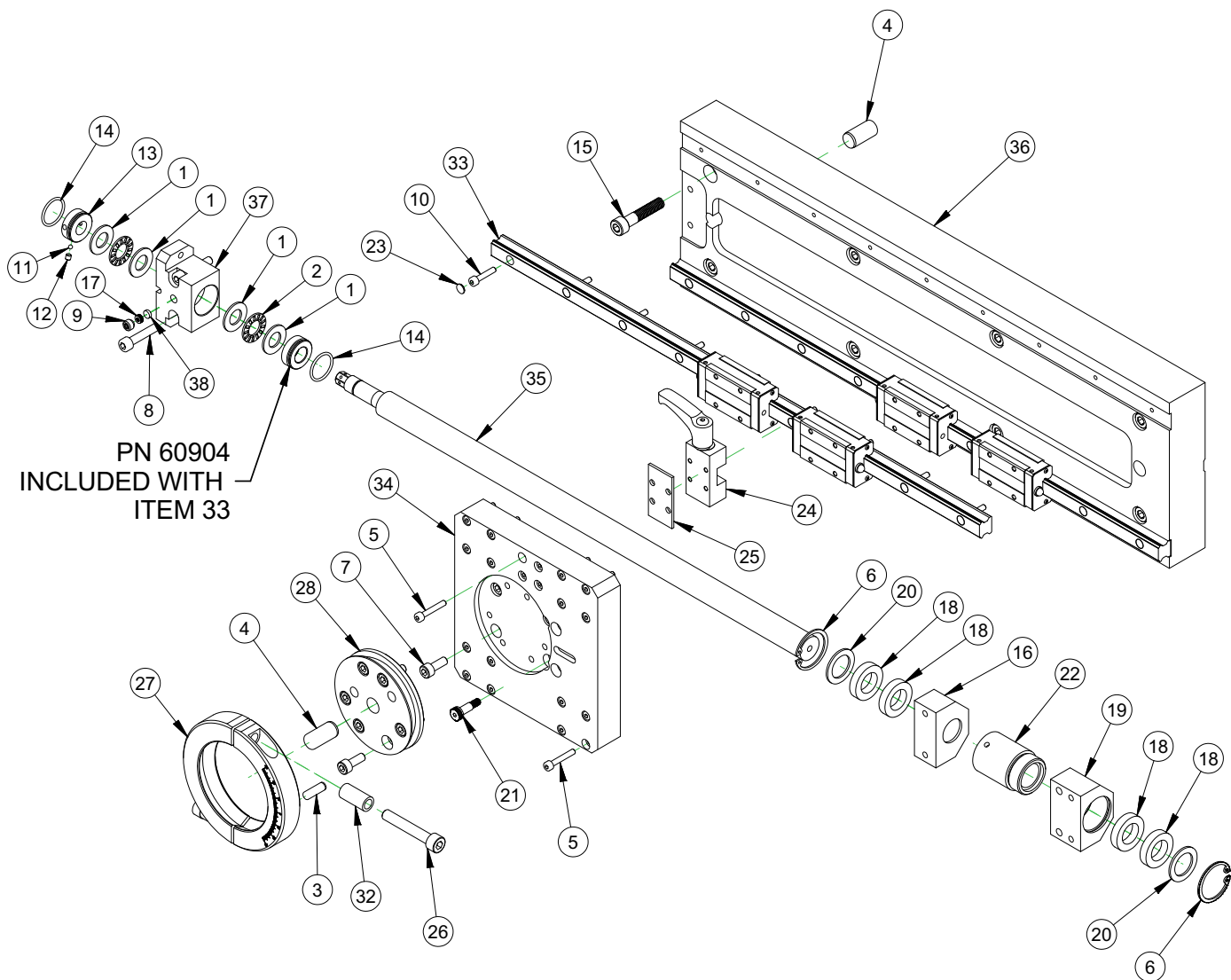
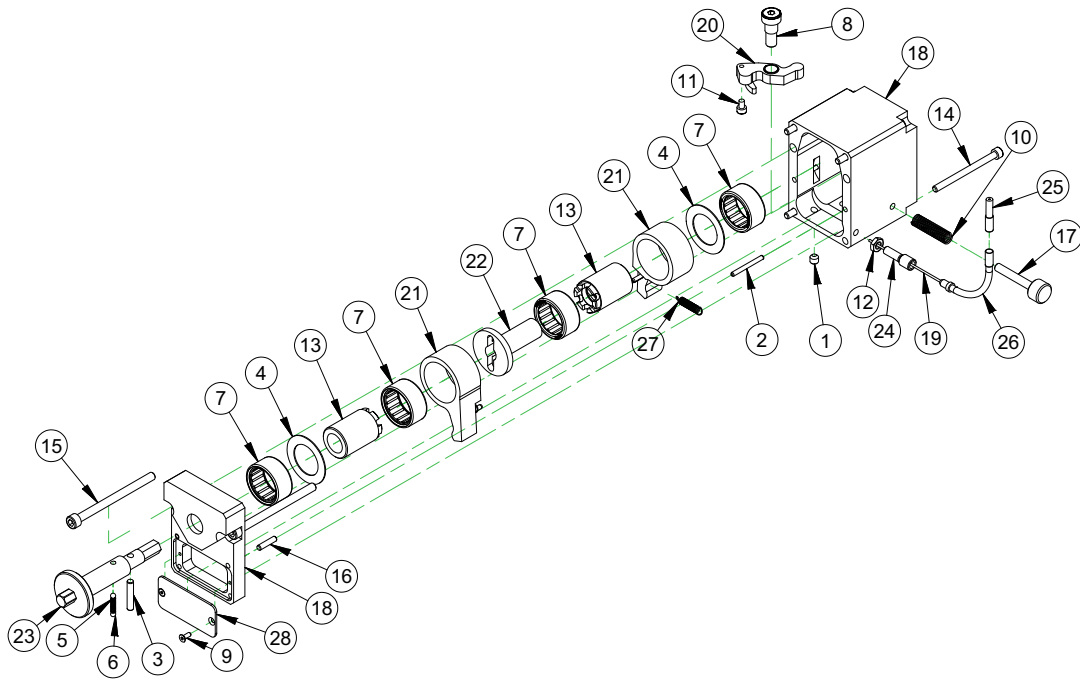

PARTS LIST

ITEM	QTY	P/N:	DESCRIPTION
1	1	10464	SCREW 1/4-20 X 1/4 SSSCP
2	2	11884	PIN DOWEL 1/8 DIA X 1-1/4
3	1	14284	PIN DOWEL 3/16 DIA X 1
4	2	15079	WASHER THRUST 1.000 ID X 1.562 OD X .030
5	1	19561	SPRING COMP .148 OD X .023 WIRE X .50 LONG STAINLESS
6	2	19562	BALL STEEL 5/32 DIA
7	4	25957	BRG ROLLER CLUTCH 1 X 1.312 X .625
8	1	29286	SCREW 3/8 X 3/8 X 5/16-18 SHLDCS
9	2	35876	SCREW M3 X .5 X 8MM FHSCS
10	1	36148	SPRING COMP .36 OD X .032 WIRE X 1.25 LONG
11	1	36152	SCREW M4 X 0.7 X 6mm SHCS
12	1	43019	NUT M6 X 1.0 JAMN ZINC PLATED
13	2	44721	DRIVE BUSHING
14	4	56357	SCREW 10-24 X 2.5 SHCS
15	2	59057	SCREW M6 X 1.0 X 80 mm SHCS CL12.9 ZINC COATED
16	2	60165	PIN DOWEL 5/32 DIA X 11/16
17	1	76599	SCREW M6 X 1.0 X 40MM KNURLED HEAD
18	1	86899	HOUSING FEEDBOX PULL CABLE
19	1	86905	CABLE BRAKE PULL 1.5MM
20	1	86909	PIVOT LINK PULL CABLE FEED
21	2	86973	CLUTCH ARM PULL CABLE FEED
22	1	86978	COUPLING FLANGED 3/8 INTERNAL HEX
23	1	86979	SHAFT PULL CABLE FEED BOX
24	1	87038	BOLT ADJUSTING M6 5MM BRAKE CABLE
25	A/R	87181	HOUSING 5MM DIA BRAKE CABLE
26	1	87198	BEND 90 DEG BRAKE CABLE
27	2	87528	SPRING EXT .18 OD X .023 WIRE X 1-1/4
28	1	87535	COVER FEEDBOX PULL CABLE

ABBILDUNG A-11. MONTAGE DES ZUGSEIL-VORSCHUBKASTENS (P/N 86900)

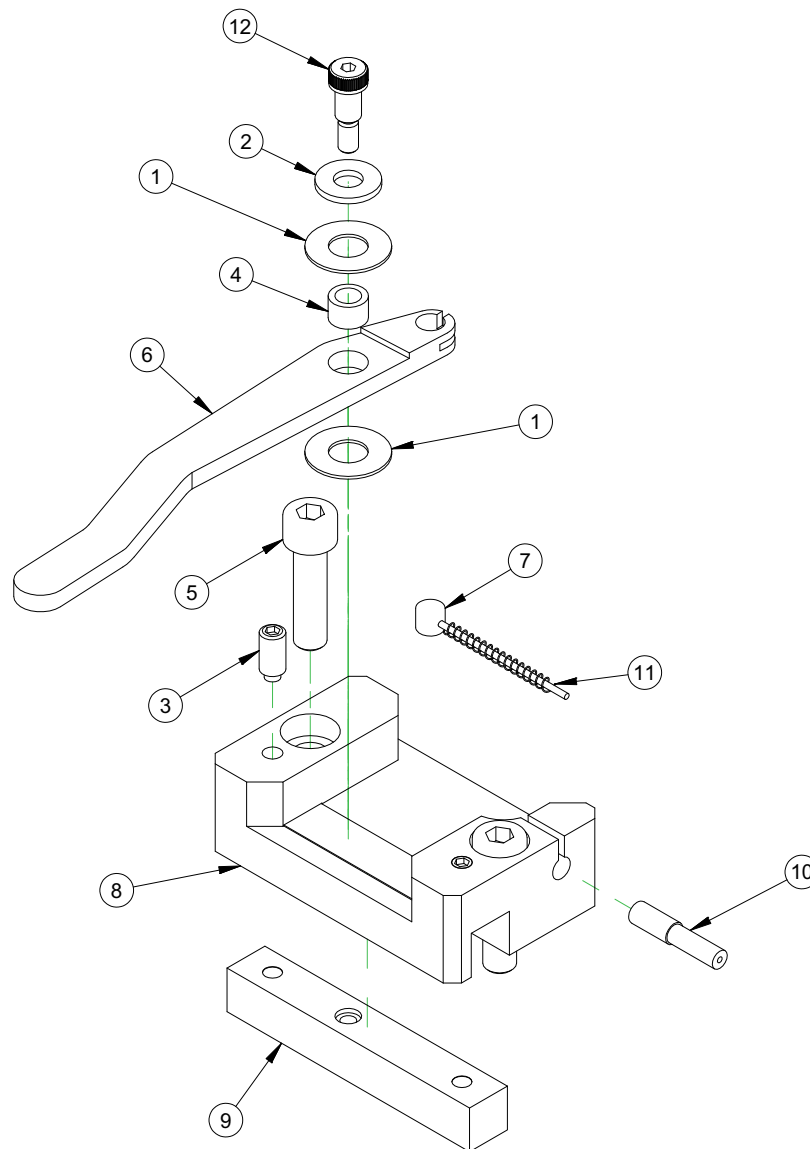

PARTS LIST			
ITEM	QTY	P/N:	DESCRIPTION
1	2	10058	WASHER THRUST .375 ID X .812 OD X .032
2	1	10702	WASHER 1/4 FLTW SAE
3	2	10848	PLUNGER DETENT SPRING STUBBY 1/4-20 X .531
4	1	15259	BUSHING OILITE 1/4 ID X 3/8 OD X 1/4
5	2	45530	SCREW M8 X 1.25 X 30mm SHCS
6	1	86904	TRIP ARM CABLE FEED
7	1	86905	CABLE BRAKE PULL 1.5MM X 1700MM
8	1	86906	BLOCK FEED TRIP ACTUATOR
9	1	86907	KEY PIVOT PULL CABLE FEED
10	A/R	87181	HOUSING 5MM DIA BRAKE CABLE
11	1	87529	SPRING COMP .136 OD X .010 WIRE X 1.34 LONG
12	1	87532	SCREW 1/4 DIA X 3/8 X 10-32 SHLDCS

ABBILDUNG A-12. MONTAGE SCHALTERS IM ZUGSEIL-VORSCHUBKASTEN (P/N 86900)

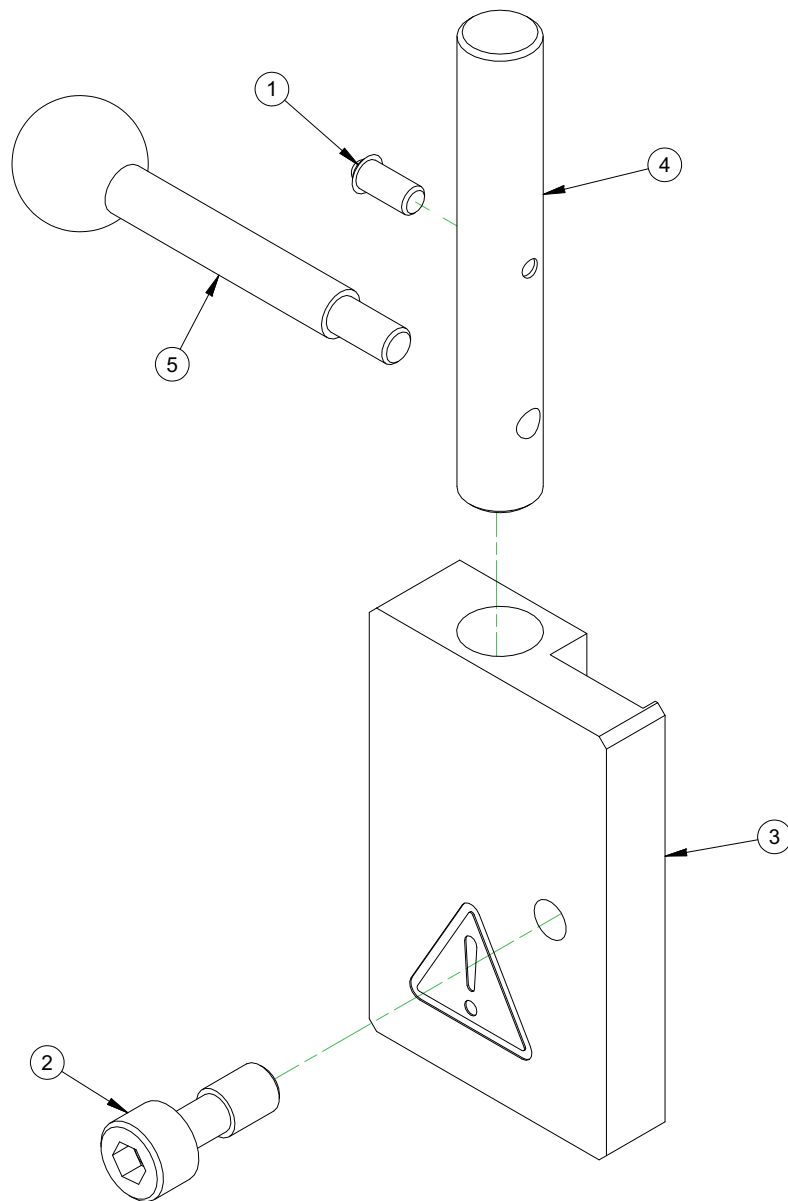

PARTS LIST			
ITEM	QTY	P/N:	DESCRIPTION
1	1	26828	PLUNGER BALL PUSHFIT
2	1	84563	SCREW M8 X 1.25 X 20MM SHCS CAPTIVE 10 THD STAINLESS
3	1	86902	BLOCK FEED TRIP
4	1	86903	ROD FEED TRIP
5	1	87023	LEVER M6 X 1.0 X 63MM ROUND RED HANDLE

ABBILDUNG A-13. MONTAGE DER VORSCHUBEIHNIT (P/N 86910)

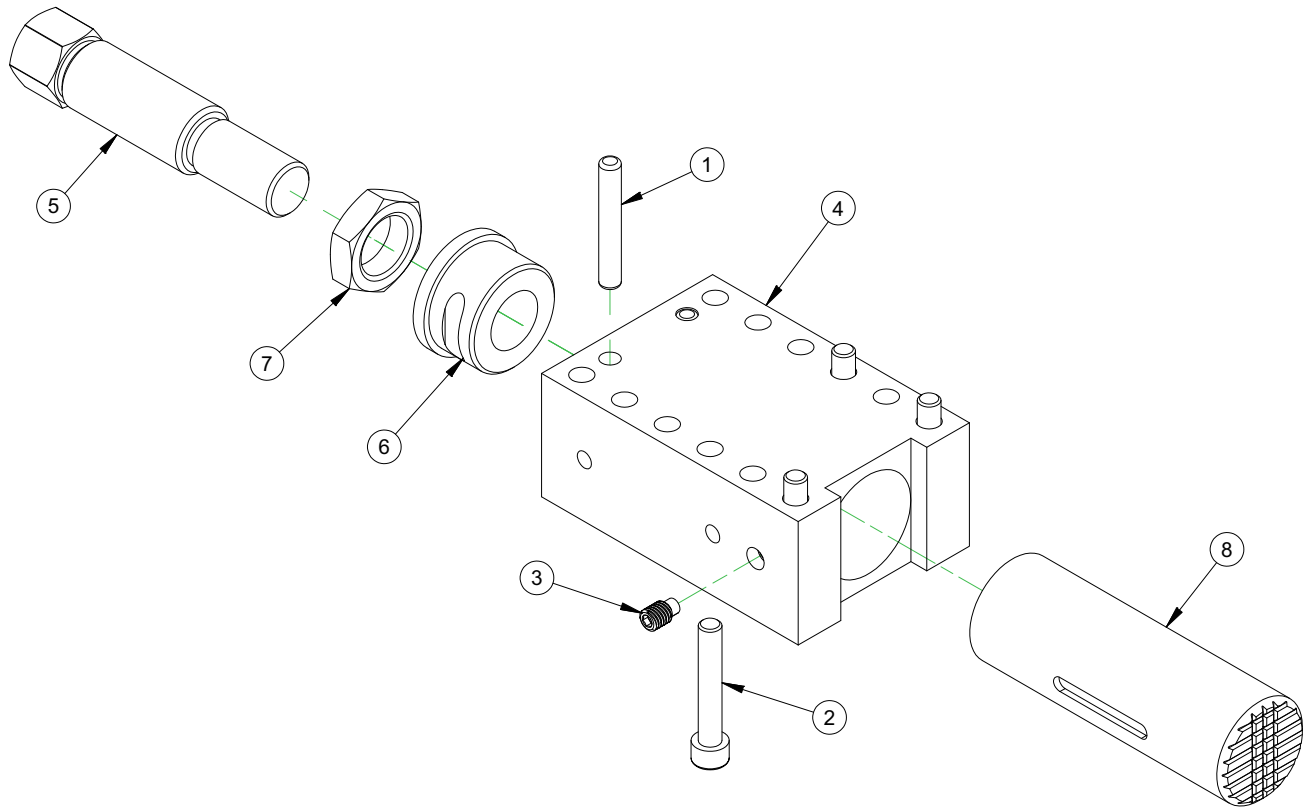

PARTS LIST			
ITEM	QTY	P/N:	DESCRIPTION
1	2	14297	PIN DOWEL 3/8 DIA X 2-1/2
2	4	45754	SCREW M10 x 1.5 x 60mm SHCS
3	1	48998	SCREW M10 X 1.5 X 16mm SSSHDP
4	1	86881	HOUSING JACKING FOOT
5	1	86882	SCREW JACKING FOOT
6	1	86883	BUSHING THD 1-1/4-7
7	1	86908	NUT 1-1/4-7 JAMN 1/2 THICK
8	1	86971	RAM JACKING NON-LEVELING

ABBILDUNG A-14. ZUSAMMENBAU SPANNFUß (P/N 86970)

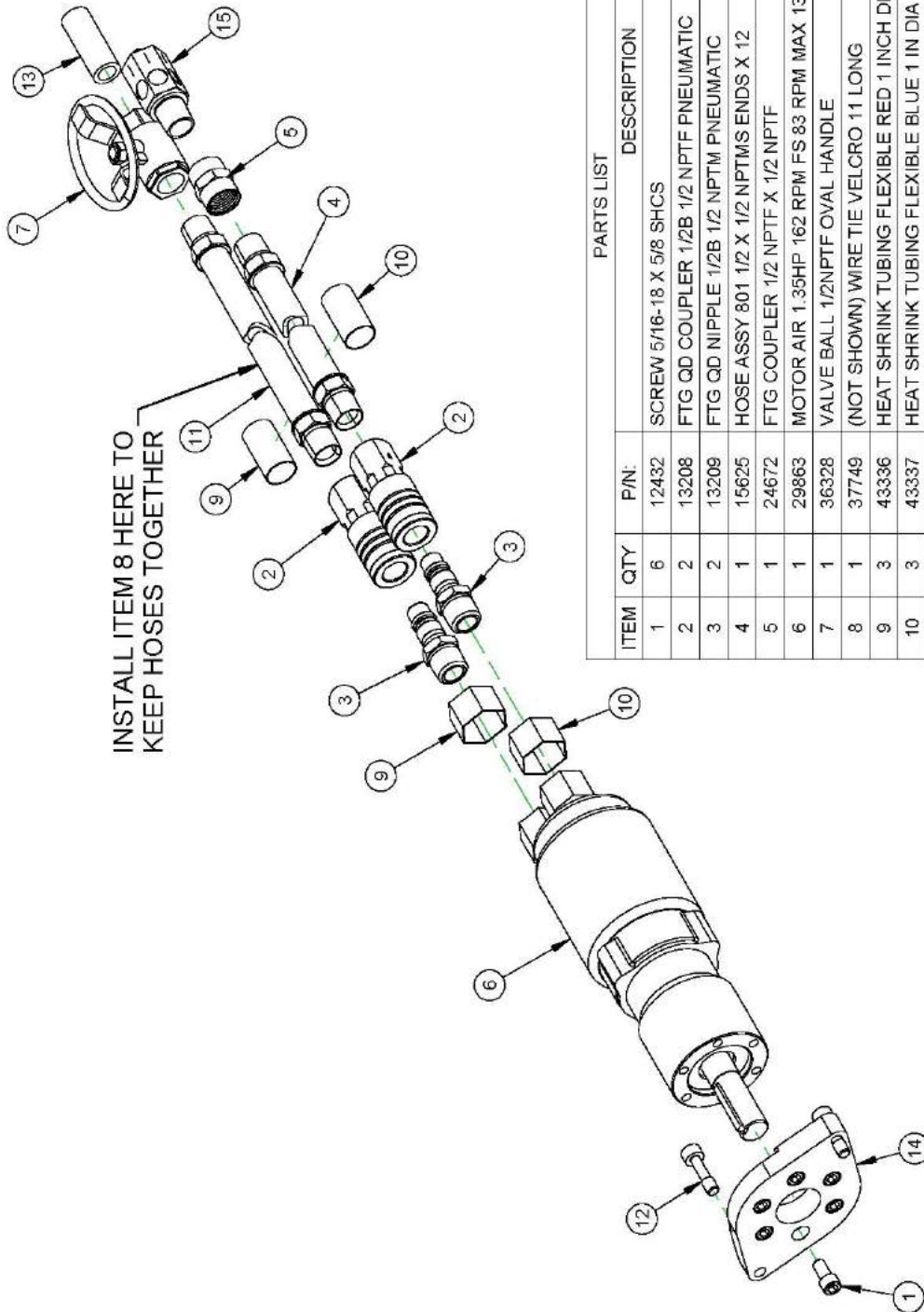

PARTS LIST		DESCRIPTION
ITEM	QTY	P/N:
1	6	12432
2	2	13208
3	2	13209
4	1	15625
5	1	24672
6	1	29863
7	1	36328
8	1	37749
9	3	43336
10	3	43337
11	1	59376
12	2	74632
13	1	76030
14	1	86893
15	1	87263

DESCRIPTION
SCREW 5/16-18 X 5/8 SHCS
FTG QD COUPLER 1/2B 1/2 NPTF PNEUMATIC
FTG QD NIPPLE 1/2B 1/2 NPTM PNEUMATIC
HOSE ASSY 801 1/2 X 1/2 NPTMS ENDS X 12
FTG COUPLER 1/2 NPTF X 1/2 NPTF
MOTOR AIR 1.35HP 162 RPM FS 83 RPM MAX 134TQ REVERSE ROTATION
VALVE BALL 1/2NPTF OVAL HANDLE
(NOT SHOWN) WIRE TIE VELCRO 11 LONG
HEAT SHRINK TUBING FLEXIBLE RED 1 INCH DIA
HEAT SHRINK TUBING FLEXIBLE BLUE 1 INCH DIA
HOSE ASSY 801 1/2 X 1/2 NPTMS ENDS X 180
SCREW M8 X 1.25 X 30 OAL X 10 THD L STAINLESS
FTG NIPPLE 1/2 NPTM X 2 INCH BRASS
PLATE AIR MOTOR MOUNT
FTG MUFFLER EXHAUST FLOW CONTROL 1/2 NPTM

ABBILDUNG A-15. MONTAGE DES ANTRIEBSMOTORS (P/N 86989)

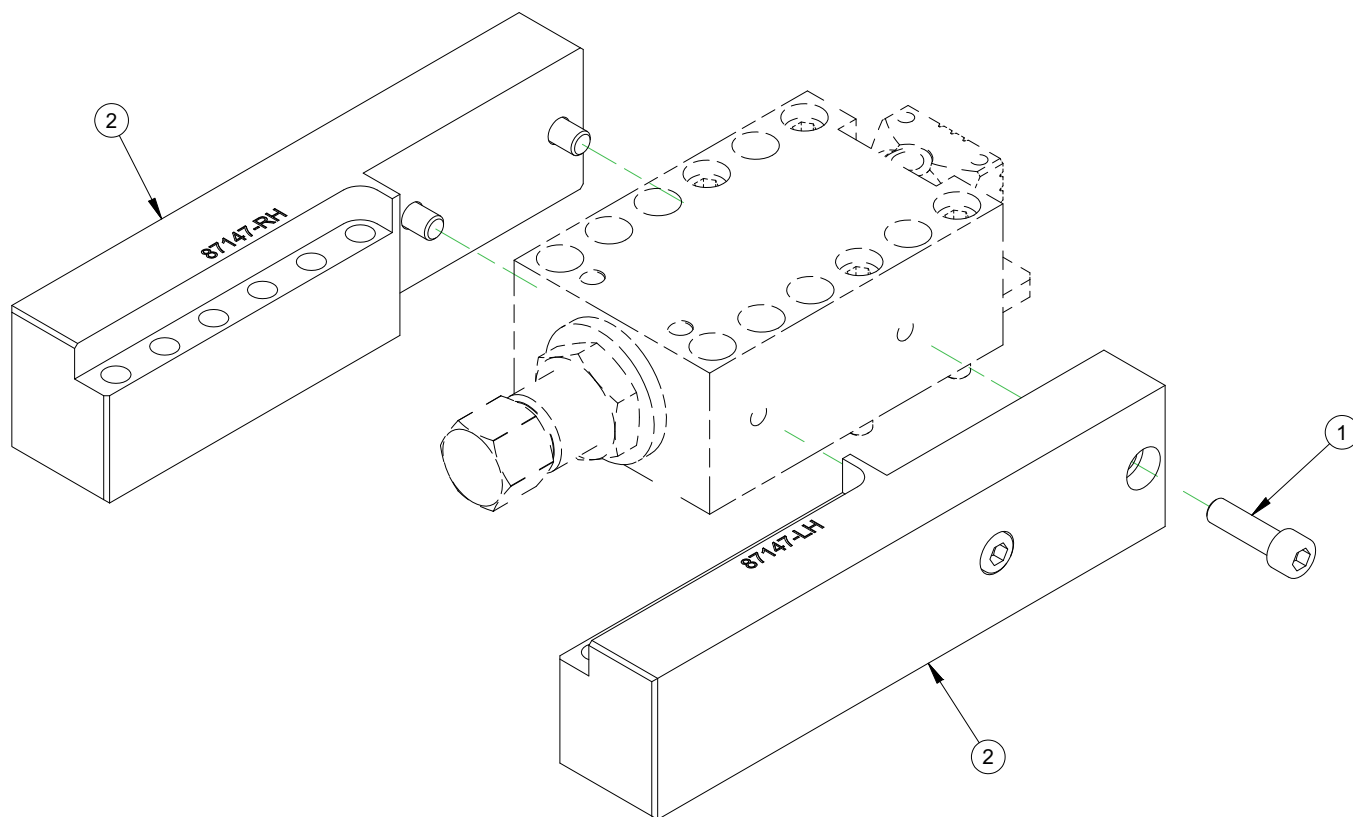

PARTS LIST			
ITEM	QTY	P/N:	DESCRIPTION
1	4	36079	SCREW M10 X 1.5 X 35mm SHCS
2	1	87147	BAR SF MOUNTING FOOT EXTENSION SET

ABBILDUNG A-16. MONTAGE DES BEFESTIGUNGSSATZES (P/N 87164)

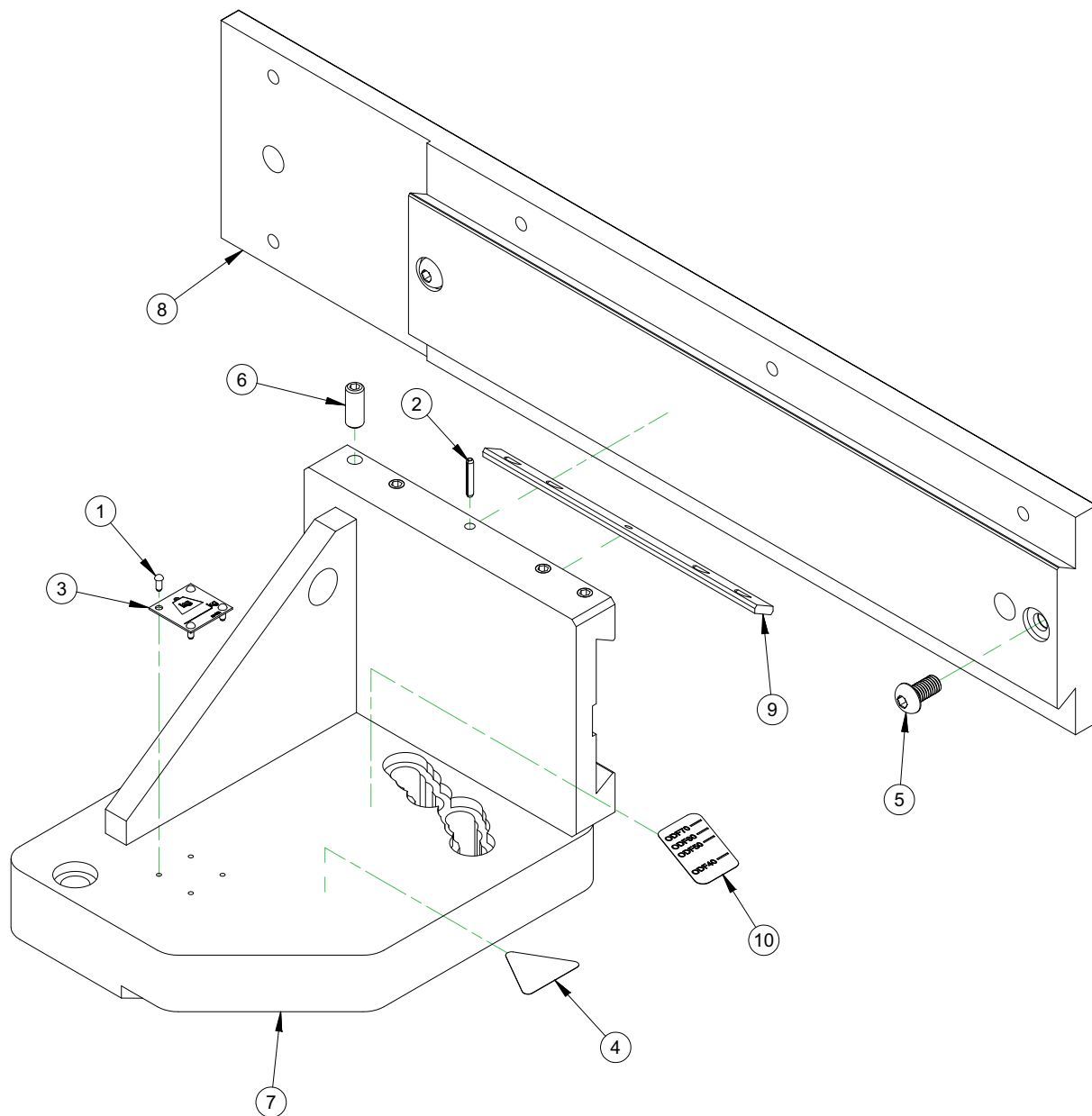

PARTS LIST			
ITEM	QTY	P/N:	DESCRIPTION
1	4	10588	SCREW DRIVE #2 x 1/4 HOLE SIZE .089
2	1	10847	PIN ROLL 1/8 DIA X 3/4
3	1	29152	PLATE MASS CE
4	1	59042	LABEL WARNING - HAND CRUSH/MOVING PARTS
5	2	59827	SCREW M8 X 1.25 X 16MM BHSCS
6	4	83708	SCREW M8 X 1.25 X 20 SSSFP
7	1	87308	WELDMENT BACKFACING ANGLE MOUNT
8	1	87309	PLATE BACKFACING MOUNT
9	1	87416	GIB .435 X .156 X 6.5 0-1 4 SS W/ DOWEL
10	1	87425	LABEL ODF BACKFACING LOCATING

ABBILDUNG A-17. MONTAGE DES RÜCKSEITEN-MONTAGESATZES (P/N 87310)

TABELLE A-1. WERKZEUGSATZ P/N 78530

Teilenummer	Beschreibung	Menge
14818	KNARRE 1/2 ZOLL	1
31158	INBUS-BIT-SATZ 5/8 X 1/2 (KB)	1
35516	DEAD BLOW HAMMER 1-3/4 KOPFDURCHMESSER (KB)	1
35821	T-GRIFF-INBUSSCHLÜSSEL, 6MM X 6	1
38678	INBUSSCHLÜSSELSATZ 1,5 - 10 MM MIT KUGELKOPF UND BONDHUS-GRIFF (KB)	1
39694	TORX-SCHLÜSSEL FT-15	1
40806	T-GRIFF-INBUSSCHLÜSSEL, 5/16 X 6	1
41471	HEBERING 3/8-16 X 0,56 1,3 ID 2,18 OD 3,79 OAL 1000 LBS	2
46250	INBUS-BIT 10MM X 1/2	1
46251	INBUS-BIT 8MM X 1/2	1
48373	KOMBISCHLÜSSEL 1-5/8 12PT	1
55924	INBUS-T-SCHLÜSSEL 3/8 (KB)	1
58354	SCHLÜSSELVERLÄNGERUNG 1/2 ZOLL X 5	1
86612	SRTECKSCHLÜSSELEINSATZ MIT 12" LANGEM SCHAFT 1-1/4 X 1/2	1
86988	7/8 STECKSCHLÜSSEL MIT GRIFF	1
87266	KARBID-EINLAGEPLATTE 55 DEG DIAMOND IC8250	5
87267	HALTERUNG FÜR KARBID-EINLAGEPLATTE 55 DEG DIAMOND 3/4 SCHAFT LH	1
87268	HALTERUNG FÜR KARBID-EINLAGEPLATTE 55 DEG DIAMOND 3/4 SCHAFT NEUTRAL	1

Diese Seite bleibt absichtlich unbeschriftet

ANHANG B SDS

SDS-Liste (Sicherheitsdatenblätter)

LPS 1.....	57
LPS 2.....	66
LPS All-Purpose Anti-Seize.....	75
Mobil Vactra Oil Heavy Medium	81

Moly Grade Anti-Seize.....	91
Nook E-100.....	95
Nook PAG-1	102
Unax AW 32	110

Diese Seite bleibt absichtlich unbeschriftet



SAFETY DATA SHEET

1. Identification

Product identifier	LPS® 1 (Aerosol)
Other means of identification	
Part Number	00116
Recommended use	An industrial lubricant designed to displace moisture from mechanical and electrical equipment, provide light-duty lubrication and short-term rust prevention.
Recommended restrictions	None known.
Manufacturer/Importer/Supplier/Distributor information	
Manufacturer	
Manufacturer	
Company name	LPS Laboratories, a division of Illinois Tool Works, Inc.
Address	4647 Hugh Howell Rd. Tucker, GA 30084 (U.S.A.)
Country	(U.S.A.) Tel: +1 770-243-8800
In Case of Emergency	1-800-424-9300 (inside U.S.) +001 703-527-3887 (outside U.S.)
Website	www.lpslabs.com
E-mail	sds@lpslabs.com

2. Hazard(s) identification

Physical hazards	Flammable aerosols	Category 1
	Gases under pressure	Compressed gas
Health hazards	Skin corrosion/irritation	Category 2
	Sensitization, skin	Category 1B
	Specific target organ toxicity, single exposure	Category 3 narcotic effects
Environmental hazards	Not classified.	
OSHA defined hazards	Not classified.	
Label elements		



Signal word	Danger
Hazard statement	Extremely flammable aerosol. Contains gas under pressure; may explode if heated. Causes skin irritation. May cause an allergic skin reaction. May cause drowsiness or dizziness.
Precautionary statement	
Prevention	Keep away from heat/sparks/open flames/hot surfaces. - No smoking. Do not spray on an open flame or other ignition source. Pressurized container: Do not pierce or burn, even after use. Avoid breathing gas. Wash thoroughly after handling. Use only outdoors or in a well-ventilated area. Contaminated work clothing must not be allowed out of the workplace. Wear protective gloves.
Response	If on skin: Wash with plenty of water. Take off contaminated clothing and wash before reuse. Specific treatment (see this label). If skin irritation or rash occurs: Get medical advice/attention. If inhaled: Remove person to fresh air and keep comfortable for breathing. Call a poison center/doctor if you feel unwell.
Storage	Store in a well-ventilated place. Keep container tightly closed. Store locked up. Protect from sunlight. Do not expose to temperatures exceeding 50°C/122°F.
Disposal	Dispose of contents/container in accordance with local/regional/national/international regulations.
Hazard(s) not otherwise classified (HNOC)	None known.
Supplemental information	None.

Material name: LPS® 1 (Aerosol)
802 Version #: 01 Issue date: 10-01-2014

SDS US
1 / 9

3. Composition/information on ingredients

Mixtures

Chemical name	Common name and synonyms	CAS number	%
Distillates Petroleum, Hydrotreated Light		64742-47-8	70 - 80
Distillates Petroleum Hydrotreated Med		64742-46-7	10 - 20
Carbon Dioxide		124-38-9	1 - 5
Sorbitan trioleate		26266-58-0	1 - 3
Calcium Sulfonate		61789-86-4	0.1 - 1

4. First-aid measures

Inhalation	Remove victim to fresh air and keep at rest in a position comfortable for breathing. Call a POISON CENTER or doctor/physician if you feel unwell.
Skin contact	Remove contaminated clothing immediately and wash skin with soap and water. In case of eczema or other skin disorders: Seek medical attention and take along these instructions. Wash contaminated clothing before reuse.
Eye contact	Immediately flush eyes with plenty of water for at least 15 minutes. Remove contact lenses, if present and easy to do. Continue rinsing. Get medical attention if irritation develops and persists.
Ingestion	In the unlikely event of swallowing contact a physician or poison control center. Rinse mouth. Do not induce vomiting without advice from poison control center. If vomiting occurs, keep head low so that stomach content doesn't get into the lungs.
Most important symptoms/effects, acute and delayed	May cause drowsiness and dizziness. Headache. Nausea, vomiting. Rash. Skin irritation. May cause redness and pain. May cause an allergic skin reaction. Dermatitis.
Indication of immediate medical attention and special treatment needed	Provide general supportive measures and treat symptomatically. Keep victim under observation. Symptoms may be delayed.
General information	Ensure that medical personnel are aware of the material(s) involved, and take precautions to protect themselves. Wash contaminated clothing before reuse.

5. Fire-fighting measures

Suitable extinguishing media	Alcohol resistant foam. Water spray. Water fog. Dry chemical powder. Dry chemicals. Carbon dioxide (CO ₂).
Unsuitable extinguishing media	Do not use water jet as an extinguisher, as this will spread the fire.
Specific hazards arising from the chemical	Contents under pressure. Pressurized container may explode when exposed to heat or flame. During fire, gases hazardous to health may be formed.
Special protective equipment and precautions for firefighters	Firefighters must use standard protective equipment including flame retardant coat, helmet with face shield, gloves, rubber boots, and in enclosed spaces, SCBA.
Fire fighting equipment/instructions	In case of fire: Stop leak if safe to do so. Move containers from fire area if you can do so without risk. Cool containers exposed to heat with water spray and remove container, if no risk is involved. Containers should be cooled with water to prevent vapor pressure build up. For massive fire in cargo area, use unmanned hose holder or monitor nozzles, if possible. If not, withdraw and let fire burn out.
Specific methods	Use standard firefighting procedures and consider the hazards of other involved materials. Move containers from fire area if you can do so without risk. Cool containers exposed to flames with water until well after the fire is out. In the event of fire and/or explosion do not breathe fumes.
General fire hazards	Extremely flammable aerosol. Contents under pressure. Pressurized container may explode when exposed to heat or flame.

6. Accidental release measures

Personal precautions, protective equipment and emergency procedures	Keep unnecessary personnel away. Keep people away from and upwind of spill/leak. Keep out of low areas. Many gases are heavier than air and will spread along ground and collect in low or confined areas (sewers, basements, tanks). Wear appropriate protective equipment and clothing during clean-up. Avoid breathing gas. Do not touch damaged containers or spilled material unless wearing appropriate protective clothing. Ventilate closed spaces before entering them. Local authorities should be advised if significant spillages cannot be contained. Use personal protection recommended in Section 8 of the SDS.
--	---

Methods and materials for containment and cleaning up

Refer to attached safety data sheets and/or instructions for use. Eliminate all ignition sources (no smoking, flares, sparks, or flames in immediate area). Keep combustibles (wood, paper, oil, etc.) away from spilled material. Stop leak if you can do so without risk. Move the cylinder to a safe and open area if the leak is irreparable. Use water spray to reduce vapors or divert vapor cloud drift. Isolate area until gas has dispersed. Dike far ahead of spill for later disposal. Scoop up used absorbent into drums or other appropriate container. Prevent entry into waterways, sewer, basements or confined areas. Following product recovery, flush area with water. For waste disposal, see section 13 of the SDS.

Environmental precautions

Avoid discharge into drains, water courses or onto the ground.

7. Handling and storage

Precautions for safe handling

Pressurized container: Do not pierce or burn, even after use. Do not use if spray button is missing or defective. Do not spray on a naked flame or any other incandescent material. Do not smoke while using or until sprayed surface is thoroughly dry. Do not cut, weld, solder, drill, grind, or expose containers to heat, flame, sparks, or other sources of ignition. Do not re-use empty containers. Avoid breathing gas. Avoid contact with eyes, skin, and clothing. Avoid prolonged exposure. Use only in well-ventilated areas. Wear appropriate personal protective equipment. Observe good industrial hygiene practices.

Conditions for safe storage, including any incompatibilities

Level 1 Aerosol.

Store locked up. Pressurized container. Protect from sunlight and do not expose to temperatures exceeding 50°C/122 °F. Do not puncture, incinerate or crush. Do not handle or store near an open flame, heat or other sources of ignition. Store in original tightly closed container. Store in a well-ventilated place. Keep out of the reach of children. Store away from incompatible materials (see Section 10 of the SDS).

8. Exposure controls/personal protection

Occupational exposure limits

U.S. - OSHA

Components	Type	Value	Form
Distillates Petroleum, Hydrotreated Light (CAS 64742-47-8)	PEL	5 mg/m3	Oil mist

US. OSHA Table Z-1 Limits for Air Contaminants (29 CFR 1910.1000)

Components	Type	Value
Carbon Dioxide (CAS 124-38-9)	PEL	9000 mg/m3
		5000 ppm

ACGIH

Components	Type	Value	Form
Distillates Petroleum, Hydrotreated Light (CAS 64742-47-8)	TWA	5 mg/m3	Oil mist

US. ACGIH Threshold Limit Values

Components	Type	Value
Carbon Dioxide (CAS 124-38-9)	STEL	30000 ppm
	TWA	5000 ppm

US. NIOSH: Pocket Guide to Chemical Hazards

Components	Type	Value
Carbon Dioxide (CAS 124-38-9)	STEL	54000 mg/m3
		30000 ppm
	TWA	9000 mg/m3 5000 ppm

Biological limit values

No biological exposure limits noted for the ingredient(s).

Appropriate engineering controls

Good general ventilation (typically 10 air changes per hour) should be used. Ventilation rates should be matched to conditions. If applicable, use process enclosures, local exhaust ventilation, or other engineering controls to maintain airborne levels below recommended exposure limits. If exposure limits have not been established, maintain airborne levels to an acceptable level.

Individual protection measures, such as personal protective equipment

Eye/face protection	Wear safety glasses with side shields (or goggles).
Skin protection	
Hand protection	Chemical resistant gloves are recommended.
Other	Avoid contact with the skin. Wear appropriate chemical resistant clothing.
Respiratory protection	When workers are facing concentrations above the exposure limit they must use appropriate certified respirators.
Thermal hazards	Not applicable.
General hygiene considerations	Always observe good personal hygiene measures, such as washing after handling the material and before eating, drinking, and/or smoking. Routinely wash work clothing and protective equipment to remove contaminants.

9. Physical and chemical properties

Appearance	Liquid.
Physical state	Gas.
Form	Aerosol.
Color	Amber.
Odor	Characteristic.
Odor threshold	Not available.
pH	Not applicable
Melting point/freezing point	< -58 °F (< -50 °C)
Initial boiling point and boiling range	415.4 °F (213 °C)
Flash point	174.2 °F (79.0 °C) Tag Closed Cup (dispensed liquid)
Evaporation rate	< 0.1 (BuAc = 1)
Flammability (solid, gas)	Flammable gas.
Upper/lower flammability or explosive limits	
Flammability limit - lower (%)	0.6 %
Flammability limit - upper (%)	7 %
Explosive limit - lower (%)	Not available.
Explosive limit - upper (%)	Not available.
Vapor pressure	< 0.05 mm Hg @ 20°C
Vapor density	> 1 (air = 1)
Relative density	0.79 - 0.81 @ 20°C
Solubility(ies)	
Solubility (water)	Not soluble
Partition coefficient (n-octanol/water)	< 1
Auto-ignition temperature	> 442.4 °F (> 228 °C)
Decomposition temperature	Not established
Viscosity	< 3.8 cSt @ 25°C
Other information	
Heat of combustion	Not established
Percent volatile	95 - 96 %
VOC (Weight %)	0.4 % per US State & Federal Consumer Product Regulations

10. Stability and reactivity

Reactivity	The product is stable and non-reactive under normal conditions of use, storage and transport.
Chemical stability	Material is stable under normal conditions.

Possibility of hazardous reactions	Hazardous polymerization does not occur.
Conditions to avoid	Avoid heat, sparks, open flames and other ignition sources. Avoid temperatures exceeding the flash point. Contact with incompatible materials.
Incompatible materials	Oxidizing agents.
Hazardous decomposition products	Carbon oxides.

11. Toxicological information

Information on likely routes of exposure

Inhalation	Vapors have a narcotic effect and may cause headache, fatigue, dizziness and nausea.
Skin contact	Causes skin irritation. May cause an allergic skin reaction.
Eye contact	Direct contact with eyes may cause temporary irritation.
Ingestion	May be fatal if swallowed and enters airways.
Symptoms related to the physical, chemical and toxicological characteristics	Symptoms may include stinging, tearing, redness, swelling, and blurred vision. Skin irritation. Exposure may cause temporary irritation, redness, or discomfort. Defatting of the skin. Rash. Vapors have a narcotic effect and may cause headache, fatigue, dizziness and nausea. Decrease in motor functions. Behavioral changes.

Information on toxicological effects

Acute toxicity Narcotic effects. May cause an allergic skin reaction.

Components	Species	Test Results
Calcium Sulfonate (CAS 61789-86-4)		
Acute		
<i>Dermal</i>		
LD50	Rabbit	> 2000 mg/kg, 24 Hours
	Rat	> 2000 mg/kg, 24 Hours
<i>Inhalation</i>		
LC50	Rat	> 1.9 mg/l, 4 Hours
<i>Oral</i>		
LD50	Rat	10000 - 20000 mg/kg
Distillates Petroleum Hydrotreated Med (CAS 64742-46-7)		
Acute		
<i>Dermal</i>		
LD50	Rabbit	> 2000 mg/kg, 24 Hours
<i>Inhalation</i>		
LC50	Rat	7640 mg/m3, 4 Hours 1.72 mg/l, 4 Hours
Distillates Petroleum, Hydrotreated Light (CAS 64742-47-8)		
Acute		
<i>Dermal</i>		
LD50	Rabbit	> 2000 mg/kg > 2000 mg/kg, 24 Hours
<i>Inhalation</i>		
LC50	Cat	> 6.4 mg/l, 6 Hours
	Rat	> 7.5 mg/l, 6 Hours > 4.3 mg/l, 4 Hours > 0.1 mg/l, 8 Hours
<i>Oral</i>		
LD50	Rat	> 5000 mg/kg
Skin corrosion/irritation	Causes skin irritation.	
Serious eye damage/eye irritation	Direct contact with eyes may cause temporary irritation.	

Respiratory or skin sensitization

Respiratory sensitization	Not a respiratory sensitizer.
Skin sensitization	May cause an allergic skin reaction.
Germ cell mutagenicity	No data available to indicate product or any components present at greater than 0.1% are mutagenic or genotoxic.
Carcinogenicity	This product is not considered to be a carcinogen by IARC, ACGIH, NTP, or OSHA.
OSHA Specifically Regulated Substances (29 CFR 1910.1001-1050)	
	Not listed.
Reproductive toxicity	This product is not expected to cause reproductive or developmental effects.
Specific target organ toxicity - single exposure	Narcotic effects.
Specific target organ toxicity - repeated exposure	Based on available data, the classification criteria are not met.
Aspiration hazard	Not likely, due to the form of the product.
Chronic effects	Prolonged inhalation may be harmful.

12. Ecological information

Ecotoxicity Harmful to aquatic life with long lasting effects.

Components	Species	Test Results
Distillates Petroleum, Hydroteated Light (CAS 64742-47-8)		
Aquatic		
Fish	LC50 Rainbow trout,donaldson trout (Oncorhynchus mykiss)	2.9 mg/l, 96 hours
Persistence and degradability	Not inherently biodegradable.	
Bioaccumulative potential	Not available.	
Partition coefficient n-octanol / water (log Kow)		
LPS® 1 (Aerosol)	< 1	
Mobility in soil	No data available.	
Other adverse effects	None known.	

13. Disposal considerations

Disposal instructions	Consult authorities before disposal. Contents under pressure. Do not puncture, incinerate or crush. Dispose of contents/container in accordance with local/regional/national/international regulations.
Local disposal regulations	Dispose in accordance with all applicable regulations.
Hazardous waste code	D003: Waste Reactive material
Waste from residues / unused products	Dispose of in accordance with local regulations. Empty containers or liners may retain some product residues. This material and its container must be disposed of in a safe manner (see: Disposal instructions).
Contaminated packaging	Empty containers should be taken to an approved waste handling site for recycling or disposal. Since emptied containers may retain product residue, follow label warnings even after container is emptied. Do not re-use empty containers.

14. Transport information

DOT

UN number	UN1950
UN proper shipping name	Aerosols, flammable
Transport hazard class(es)	
Class	2.1
Subsidiary risk	-
Label(s)	2.1
Packing group	Not applicable.
Environmental hazards	
Marine pollutant	No
Special precautions for user	Read safety instructions, SDS and emergency procedures before handling.
Special provisions	N82
Packaging exceptions	306

Material name: LPS® 1 (Aerosol)

802 Version #: 01 Issue date: 10-01-2014

SDS US

6 / 9

Packaging non bulk	None
Packaging bulk	None
IATA	
UN number	UN1950
UN proper shipping name	Aerosols, flammable
Transport hazard class(es)	
Class	2.1
Subsidiary risk	-
Packing group	Not applicable.
Environmental hazards	No
ERG Code	10L
Special precautions for user	Read safety instructions, SDS and emergency procedures before handling.
Other information	
Passenger and cargo aircraft	Allowed.
Cargo aircraft only	Allowed.
IMDG	
UN number	UN1950
UN proper shipping name	AEROSOLS, Flammable
Transport hazard class(es)	
Class	2.1
Subsidiary risk	-
Label(s)	2.1
Packing group	Not applicable.
Environmental hazards	
Marine pollutant	No
EmS	F-D, S-U
Special precautions for user	Read safety instructions, SDS and emergency procedures before handling.
Transport in bulk according to Annex II of MARPOL 73/78 and the IBC Code	This substance/mixture is not intended to be transported in bulk.

DOT



IATA; IMDG



15. Regulatory information

US federal regulations This product is a "Hazardous Chemical" as defined by the OSHA Hazard Communication Standard, 29 CFR 1910.1200. All components are on the U.S. EPA TSCA Inventory List.

TSCA Section 12(b) Export Notification (40 CFR 707, Subpt. D)
Not regulated.

CERCLA Hazardous Substance List (40 CFR 302.4)

Not listed.

SARA 304 Emergency release notification

Not regulated.

OSHA Specifically Regulated Substances (29 CFR 1910.1001-1050)

Not listed.

Superfund Amendments and Reauthorization Act of 1986 (SARA)

Hazard categories Immediate Hazard - Yes
 Delayed Hazard - No
 Fire Hazard - Yes
 Pressure Hazard - Yes
 Reactivity Hazard - No

SARA 302 Extremely hazardous substance

Not listed.

SARA 311/312 Hazardous chemical Yes**SARA 313 (TRI reporting)**

Not regulated.

Other federal regulations**Clean Air Act (CAA) Section 112 Hazardous Air Pollutants (HAPs) List**

Not regulated.

Clean Air Act (CAA) Section 112(r) Accidental Release Prevention (40 CFR 68.130)

Not regulated.

Safe Drinking Water Act (SDWA) Not regulated.**US state regulations****US. California Controlled Substances. CA Department of Justice (California Health and Safety Code Section 11100)**

Not listed.

US. Massachusetts RTK - Substance List

Carbon Dioxide (CAS 124-38-9)

US. New Jersey Worker and Community Right-to-Know Act

Carbon Dioxide (CAS 124-38-9)

US. Pennsylvania Worker and Community Right-to-Know Law

Carbon Dioxide (CAS 124-38-9)

US. Rhode Island RTK

Not regulated.

US. California Proposition 65

California Safe Drinking Water and Toxic Enforcement Act of 1986 (Proposition 65): This material is not known to contain any chemicals currently listed as carcinogens or reproductive toxins.

International Inventories

Country(s) or region	Inventory name	On inventory (yes/no)*
Australia	Australian Inventory of Chemical Substances (AICS)	Yes
Canada	Domestic Substances List (DSL)	Yes
Canada	Non-Domestic Substances List (NDSL)	No
China	Inventory of Existing Chemical Substances in China (IECSC)	No
Europe	European Inventory of Existing Commercial Chemical Substances (EINECS)	Yes
Europe	European List of Notified Chemical Substances (ELINCS)	No
Japan	Inventory of Existing and New Chemical Substances (ENCS)	No
Korea	Existing Chemicals List (ECL)	Yes
New Zealand	New Zealand Inventory	No
Philippines	Philippine Inventory of Chemicals and Chemical Substances (PICCS)	Yes

Country(s) or region	Inventory name	On inventory (yes/no)*
United States & Puerto Rico	Toxic Substances Control Act (TSCA) Inventory	Yes

*A "Yes" indicates that all components of this product comply with the inventory requirements administered by the governing country(s)

A "No" indicates that one or more components of the product are not listed or exempt from listing on the inventory administered by the governing country(s).

16. Other information, including date of preparation or last revision

Issue date 10-01-2014

Version # 01

Disclaimer LPS Laboratories cannot anticipate all conditions under which this information and its product, or the products of other manufacturers in combination with its product, may be used. It is the user's responsibility to ensure safe conditions for handling, storage and disposal of the product, and to assume liability for loss, injury, damage or expense due to improper use. The information provided in this Safety Data Sheet is correct to the best of our knowledge, information and belief at the date of its publication. The information given is designed only as a guidance for safe handling, use, processing, storage, transportation, disposal and release and is not to be considered a warranty or quality specification. The information relates only to the specific material designated and may not be valid for such material used in combination with any other materials or in any process, unless specified in the text.



SAFETY DATA SHEET

1. Identification

Product identifier	LPS® 2 (Aerosol)
Other means of identification	
Part Number	00216
Recommended use	An industrial lubricant designed to displace moisture from equipment, provide heavy-duty lubrication and rust prevention.
Recommended restrictions	None known.
Manufacturer/Importer/Supplier/Distributor information	
Manufacturer	
Manufacturer	
Company name	LPS Laboratories, a division of Illinois Tool Works, Inc.
Address	4647 Hugh Howell Rd. Tucker, GA 30084 (U.S.A.)
Country	Tel: +1 770-243-8800
In Case of Emergency	1-800-424-9300 (inside U.S.) +001 703-527-3887 (outside U.S.)
Website	www.lpslabs.com
E-mail	sds@lpslabs.com

2. Hazard(s) identification

Physical hazards	Flammable aerosols	Category 1
	Gases under pressure	Compressed gas
Health hazards	Skin corrosion/irritation	Category 2
	Serious eye damage/eye irritation	Category 2A
	Specific target organ toxicity, single exposure	Category 3 narcotic effects
Environmental hazards	Not classified.	
OSHA defined hazards	Not classified.	
Label elements		



Signal word	Danger
Hazard statement	Extremely flammable aerosol. Contains gas under pressure; may explode if heated. Causes skin irritation. Causes serious eye irritation. May cause drowsiness or dizziness.
Precautionary statement	
Prevention	Keep away from heat/sparks/open flames/hot surfaces. - No smoking. Do not spray on an open flame or other ignition source. Pressurized container: Do not pierce or burn, even after use. Avoid breathing gas. Wash thoroughly after handling. Use only outdoors or in a well-ventilated area. Wear protective gloves. Wear eye/face protection.
Response	If on skin: Wash with plenty of water. If inhaled: Remove person to fresh air and keep comfortable for breathing. If in eyes: Rinse cautiously with water for several minutes. Remove contact lenses, if present and easy to do. Continue rinsing. Call a poison center/doctor if you feel unwell. Specific treatment (see this label). If skin irritation occurs: Get medical advice/attention. If eye irritation persists: Get medical advice/attention. Take off contaminated clothing and wash before reuse.
Storage	Store in a well-ventilated place. Keep container tightly closed. Store locked up. Protect from sunlight. Do not expose to temperatures exceeding 50°C/122°F.
Disposal	Dispose of contents/container in accordance with local/regional/national/international regulations.
Hazard(s) not otherwise classified (HNOC)	None known.

Material name: LPS® 2 (Aerosol)
729 Version #: 01 Issue date: 09-22-2014

SDS US
1 / 9

Supplemental information None.

3. Composition/information on ingredients

Mixtures

Chemical name	Common name and synonyms	CAS number	%
Distillates Petroleum, Hydrotreated Light		64742-47-8	70 - 80
Petroleum Oil		64742-52-5	10 - 20
Carbon Dioxide		124-38-9	1 - 5

4. First-aid measures

Inhalation	Remove victim to fresh air and keep at rest in a position comfortable for breathing. For breathing difficulties, oxygen may be necessary. Call a physician if symptoms develop or persist.
Skin contact	Wash off with soap and water. Get medical attention if irritation develops and persists.
Eye contact	Immediately flush eyes with plenty of water for at least 15 minutes. Remove contact lenses, if present and easy to do. Continue rinsing. Get medical attention if irritation develops and persists.
Ingestion	Call a physician or poison control center immediately. Only induce vomiting at the instruction of medical personnel. Never give anything by mouth to an unconscious person. If vomiting occurs, keep head low so that stomach content doesn't get into the lungs.
Most important symptoms/effects, acute and delayed	Dermatitis. Rash. Symptoms of overexposure may be headache, dizziness, tiredness, nausea and vomiting. Skin irritation. May cause redness and pain.
Indication of immediate medical attention and special treatment needed	Provide general supportive measures and treat symptomatically.
General information	Ensure that medical personnel are aware of the material(s) involved, and take precautions to protect themselves. Call a POISON CENTER or doctor/physician if you feel unwell.

5. Fire-fighting measures

Suitable extinguishing media	Powder. Alcohol resistant foam. Water. Water spray. Dry chemicals. Carbon dioxide (CO ₂).
Unsuitable extinguishing media	Do not use water jet as an extinguisher, as this will spread the fire.
Specific hazards arising from the chemical	Contents under pressure. Pressurized container may explode when exposed to heat or flame.
Special protective equipment and precautions for firefighters	Firefighters must use standard protective equipment including flame retardant coat, helmet with face shield, gloves, rubber boots, and in enclosed spaces, SCBA.
Fire fighting equipment/instructions	In case of fire: Stop leak if safe to do so. Move containers from fire area if you can do so without risk. Cool containers exposed to heat with water spray and remove container, if no risk is involved. Containers should be cooled with water to prevent vapor pressure build up. For massive fire in cargo area, use unmanned hose holder or monitor nozzles, if possible. If not, withdraw and let fire burn out.
Specific methods	Use standard firefighting procedures and consider the hazards of other involved materials. Move containers from fire area if you can do so without risk. Cool containers exposed to flames with water until well after the fire is out. In the event of fire and/or explosion do not breathe fumes.
General fire hazards	Extremely flammable aerosol.

6. Accidental release measures

Personal precautions, protective equipment and emergency procedures	Keep unnecessary personnel away. Keep people away from and upwind of spill/leak. Keep out of low areas. Wear appropriate protective equipment and clothing during clean-up. Do not touch damaged containers or spilled material unless wearing appropriate protective clothing. Ventilate closed spaces before entering them. Local authorities should be advised if significant spillages cannot be contained. Use personal protection recommended in Section 8 of the SDS.
Methods and materials for containment and cleaning up	Refer to attached safety data sheets and/or instructions for use. Eliminate all ignition sources (no smoking, flares, sparks, or flames in immediate area). Keep combustibles (wood, paper, oil, etc.) away from spilled material. Stop leak if you can do so without risk. Move the cylinder to a safe and open area if the leak is irreparable. Isolate area until gas has dispersed. Use water spray to reduce vapors or divert vapor cloud drift. Scoop up used absorbent into drums or other appropriate container. Prevent entry into waterways, sewer, basements or confined areas. Following product recovery, flush area with water. For waste disposal, see section 13 of the SDS.
Environmental precautions	Avoid discharge into drains, water courses or onto the ground.

Material name: LPS® 2 (Aerosol)
729 Version #: 01 Issue date: 09-22-2014

SDS US
2 / 9

7. Handling and storage

Precautions for safe handling

Pressurized container: Do not pierce or burn, even after use. Do not use if spray button is missing or defective. Do not spray on a naked flame or any other incandescent material. Do not smoke while using or until sprayed surface is thoroughly dry. Do not cut, weld, solder, drill, grind, or expose containers to heat, flame, sparks, or other sources of ignition. All equipment used when handling the product must be grounded. Do not re-use empty containers. Avoid prolonged or repeated contact with skin. Avoid prolonged exposure. Use only in well-ventilated areas. Wear appropriate personal protective equipment. Wash hands thoroughly after handling. Observe good industrial hygiene practices.

Conditions for safe storage, including any incompatibilities

Level 3 Aerosol.

Store locked up. Pressurized container. Protect from sunlight and do not expose to temperatures exceeding 50°C/122 °F. Do not puncture, incinerate or crush. Do not handle or store near an open flame, heat or other sources of ignition. This material can accumulate static charge which may cause spark and become an ignition source. Prevent electrostatic charge build-up by using common bonding and grounding techniques. Store in original tightly closed container. Store in a well-ventilated place. Store away from incompatible materials (see Section 10 of the SDS). Keep out of the reach of children.

8. Exposure controls/personal protection

Occupational exposure limits

U.S. - OSHA

Components

Components	Type	Value	Form
Distillates Petroleum, Hydrotreated Light (CAS 64742-47-8)	PEL	5 mg/m3	Oil mist
Petroleum Oil (CAS 64742-52-5)	PEL	5 mg/m3	Oil mist

US. OSHA Table Z-1 Limits for Air Contaminants (29 CFR 1910.1000)

Components

Components	Type	Value
Carbon Dioxide (CAS 124-38-9)	PEL	9000 mg/m3 5000 ppm

ACGIH

Components

Components	Type	Value	Form
Distillates Petroleum, Hydrotreated Light (CAS 64742-47-8)	TWA	5 mg/m3	Oil mist
Petroleum Oil (CAS 64742-52-5)	TWA	5 mg/m3	Oil mist

US. ACGIH Threshold Limit Values

Components

Components	Type	Value
Carbon Dioxide (CAS 124-38-9)	STEL	30000 ppm
	TWA	5000 ppm

US. NIOSH: Pocket Guide to Chemical Hazards

Components

Components	Type	Value
Carbon Dioxide (CAS 124-38-9)	STEL	54000 mg/m3 30000 ppm
	TWA	9000 mg/m3 5000 ppm

Biological limit values

No biological exposure limits noted for the ingredient(s).

Appropriate engineering controls

Good general ventilation (typically 10 air changes per hour) should be used. Ventilation rates should be matched to conditions. If applicable, use process enclosures, local exhaust ventilation, or other engineering controls to maintain airborne levels below recommended exposure limits. If exposure limits have not been established, maintain airborne levels to an acceptable level. Eye wash facilities and emergency shower must be available when handling this product.

Individual protection measures, such as personal protective equipment

Eye/face protection

Wear safety glasses with side shields (or goggles).

Material name: LPS@ 2 (Aerosol)

729 Version #: 01 Issue date: 09-22-2014

SDS US

3 / 9

Skin protection	
Hand protection	Chemical resistant gloves are recommended.
Other	Wear suitable protective clothing.
Respiratory protection	In case of insufficient ventilation, wear suitable respiratory equipment.
Thermal hazards	Not applicable.
General hygiene considerations	When using, do not eat, drink or smoke. Always observe good personal hygiene measures, such as washing after handling the material and before eating, drinking, and/or smoking. Routinely wash work clothing and protective equipment to remove contaminants.

9. Physical and chemical properties

Appearance	Liquid.
Physical state	Gas.
Form	Aerosol.
Color	Brown
Odor	Slight petroleum odor, Cherry
Odor threshold	Not established
pH	Not applicable
Melting point/freezing point	< -58 °F (< -50 °C)
Initial boiling point and boiling range	383 °F (195 °C) @ 101 kPa
Flash point	174.2 °F (79.0 °C) Tag Closed Cup (dispensed liquid)
Evaporation rate	< 0.1 BuAc
Flammability (solid, gas)	Flammable gas.
Upper/lower flammability or explosive limits	
Flammability limit - lower (%)	0.6 %
Flammability limit - upper (%)	7 %
Explosive limit - lower (%)	Not available.
Explosive limit - upper (%)	Not available.
Vapor pressure	< 0.05 mm Hg @ 20°C (dispensed liquid)
Vapor density	4.7 (air = 1)
Relative density	Not available.
Solubility(ies)	
Solubility (water)	< 3 %
Partition coefficient (n-octanol/water)	< 1
Auto-ignition temperature	> 442.4 °F (> 228 °C)
Decomposition temperature	Not established
Viscosity	< 7 cSt
Viscosity temperature	77 °F (25 °C)
Other information	
Heat of combustion	> 30 kJ/g
Percent volatile	92 - 95 %
Specific gravity	0.82 - 0.86 @ 20°C

10. Stability and reactivity

Reactivity	The product is stable and non-reactive under normal conditions of use, storage and transport.
Chemical stability	Material is stable under normal conditions.
Possibility of hazardous reactions	Hazardous polymerization does not occur.
Conditions to avoid	Avoid heat, sparks, open flames and other ignition sources. Avoid temperatures exceeding the flash point. Contact with incompatible materials.

Incompatible materials Strong oxidizing agents.
Hazardous decomposition products Carbon oxides.

11. Toxicological information

Information on likely routes of exposure

Inhalation Vapors have a narcotic effect and may cause headache, fatigue, dizziness and nausea.
Skin contact Causes skin irritation.
Eye contact Causes serious eye irritation.
Ingestion May cause discomfort if swallowed.

Symptoms related to the physical, chemical and toxicological characteristics Irritating to eyes, respiratory system and skin. Symptoms may include stinging, tearing, redness, swelling, and blurred vision. Exposure may cause temporary irritation, redness, or discomfort. Vapors have a narcotic effect and may cause headache, fatigue, dizziness and nausea.

Information on toxicological effects

Acute toxicity Narcotic effects.

Components	Species	Test Results
Distillates Petroleum, Hydrotreated Light (CAS 64742-47-8)		
Acute		
<i>Dermal</i>		
LD50	Rabbit	> 2000 mg/kg > 2000 mg/kg, 24 Hours
<i>Inhalation</i>		
LC50	Cat	> 6.4 mg/l, 6 Hours
	Rat	> 7.5 mg/l, 6 Hours > 4.3 mg/l, 4 Hours > 0.1 mg/l, 8 Hours
<i>Oral</i>		
LD50	Rat	> 5000 mg/kg
Petroleum Oil (CAS 64742-52-5)		
Acute		
<i>Dermal</i>		
LD50	Rabbit	> 2000 mg/kg > 2000 mg/kg, 24 Hours
<i>Inhalation</i>		
LC50	Rat	2.18 mg/l, 4 Hours
<i>Oral</i>		
LD50	Rat	5000 mg/kg
Skin corrosion/irritation	Causes skin irritation.	
Serious eye damage/eye irritation	Causes serious eye irritation.	
Respiratory or skin sensitization		
Respiratory sensitization	Not a respiratory sensitizer.	
Skin sensitization	This product is not expected to cause skin sensitization.	
Germ cell mutagenicity	No data available to indicate product or any components present at greater than 0.1% are mutagenic or genotoxic.	
Carcinogenicity	This product is not considered to be a carcinogen by IARC, ACGIH, NTP, or OSHA.	
OSHA Specifically Regulated Substances (29 CFR 1910.1001-1050)		
Not listed.		
Reproductive toxicity	This product is not expected to cause reproductive or developmental effects.	
Specific target organ toxicity - single exposure	Narcotic effects.	

Specific target organ toxicity - repeated exposure Based on available data, the classification criteria are not met.

Aspiration hazard Not likely, due to the form of the product.

Chronic effects Prolonged inhalation may be harmful.

12. Ecological information

Ecotoxicity The product is not classified as environmentally hazardous. However, this does not exclude the possibility that large or frequent spills can have a harmful or damaging effect on the environment.

Components	Species	Test Results
Distillates Petroleum, Hydrotreated Light (CAS 64742-47-8)		
Aquatic		
Fish	LC50 Rainbow trout, donaldson trout (Oncorhynchus mykiss)	2.9 mg/l, 96 hours

Persistence and degradability Not inherently biodegradable.

Bioaccumulative potential Not available.

Partition coefficient n-octanol / water (log Kow)
LPS® 2 (Aerosol) < 1

Mobility in soil No data available.

Other adverse effects None known.

13. Disposal considerations

Disposal instructions Consult authorities before disposal. Contents under pressure. Do not puncture, incinerate or crush. Dispose of contents/container in accordance with local/regional/national/international regulations.

Local disposal regulations Dispose in accordance with all applicable regulations.

Hazardous waste code D003: Waste Reactive material

Waste from residues / unused products Dispose of in accordance with local regulations. Empty containers or liners may retain some product residues. This material and its container must be disposed of in a safe manner (see: Disposal instructions).

Contaminated packaging Empty containers should be taken to an approved waste handling site for recycling or disposal. Since emptied containers may retain product residue, follow label warnings even after container is emptied. Do not re-use empty containers.

14. Transport information

DOT

UN number	UN1950
UN proper shipping name	Aerosols, flammable
Transport hazard class(es)	
Class	2.1
Subsidiary risk	-
Label(s)	2.1
Packing group	Not applicable.
Environmental hazards	
Marine pollutant	No
Special precautions for user	Read safety instructions, SDS and emergency procedures before handling. Read safety instructions, SDS and emergency procedures before handling.
Packaging exceptions	306
Packaging non bulk	None
Packaging bulk	None

IATA

UN number	UN1950
UN proper shipping name	Aerosols, flammable
Transport hazard class(es)	
Class	2.1
Subsidiary risk	-
Label(s)	2.1
Packing group	Not applicable.
Environmental hazards	No.
ERG Code	10L

Special precautions for user Read safety instructions, SDS and emergency procedures before handling. Read safety instructions, SDS and emergency procedures before handling.

Other information

Passenger and cargo aircraft Allowed.

Cargo aircraft only Allowed.

IMDG

UN number UN1950

UN proper shipping name AEROSOLS, flammable

Transport hazard class(es)

Class 2.1

Subsidiary risk -

Label(s) 2.1

Packing group Not applicable.

Environmental hazards

Marine pollutant No

Ems Not available.

Special precautions for user Read safety instructions, SDS and emergency procedures before handling. Read safety instructions, SDS and emergency procedures before handling.

Transport in bulk according to Annex II of MARPOL 73/78 and the IBC Code Not applicable.

DOT



IATA; IMDG



15. Regulatory information

US federal regulations This product is a "Hazardous Chemical" as defined by the OSHA Hazard Communication Standard, 29 CFR 1910.1200.

TSCA Section 12(b) Export Notification (40 CFR 707, Subpt. D)

Not regulated.

CERCLA Hazardous Substance List (40 CFR 302.4)

Not listed.

SARA 304 Emergency release notification

Not regulated.

OSHA Specifically Regulated Substances (29 CFR 1910.1001-1050)

Not listed.

Superfund Amendments and Reauthorization Act of 1986 (SARA)

Hazard categories Immediate Hazard - Yes
 Delayed Hazard - No
 Fire Hazard - Yes
 Pressure Hazard - Yes
 Reactivity Hazard - No

SARA 302 Extremely hazardous substance

Not listed.

SARA 311/312 Hazardous chemical Yes

SARA 313 (TRI reporting)

Not regulated.

Other federal regulations

Clean Air Act (CAA) Section 112 Hazardous Air Pollutants (HAPs) List

Not regulated.

Clean Air Act (CAA) Section 112(r) Accidental Release Prevention (40 CFR 68.130)

Not regulated.

Safe Drinking Water Act (SDWA) Not regulated.

US state regulations

US. California Controlled Substances. CA Department of Justice (California Health and Safety Code Section 11100)

Not listed.

US. Massachusetts RTK - Substance List

Carbon Dioxide (CAS 124-38-9)

US. New Jersey Worker and Community Right-to-Know Act

Carbon Dioxide (CAS 124-38-9)

US. Pennsylvania Worker and Community Right-to-Know Law

Carbon Dioxide (CAS 124-38-9)

US. Rhode Island RTK

Not regulated.

US. California Proposition 65

California Safe Drinking Water and Toxic Enforcement Act of 1986 (Proposition 65): This material is not known to contain any chemicals currently listed as carcinogens or reproductive toxins.

International Inventories

Country(s) or region	Inventory name	On inventory (yes/no)*
Australia	Australian Inventory of Chemical Substances (AICS)	Yes
Canada	Domestic Substances List (DSL)	Yes
Canada	Non-Domestic Substances List (NDSL)	No
China	Inventory of Existing Chemical Substances in China (IECSC)	No
Europe	European Inventory of Existing Commercial Chemical Substances (EINECS)	Yes
Europe	European List of Notified Chemical Substances (ELINCS)	No
Japan	Inventory of Existing and New Chemical Substances (ENCS)	No
Korea	Existing Chemicals List (ECL)	Yes
New Zealand	New Zealand Inventory	No
Philippines	Philippine Inventory of Chemicals and Chemical Substances (PICCS)	Yes
United States & Puerto Rico	Toxic Substances Control Act (TSCA) Inventory	Yes

*A "Yes" indicates that all components of this product comply with the inventory requirements administered by the governing country(s)

A "No" indicates that one or more components of the product are not listed or exempt from listing on the inventory administered by the governing country(s).

16. Other information, including date of preparation or last revision

Issue date 09-22-2014
Version # 01

Disclaimer

The information provided in this Safety Data Sheet is correct to the best of our knowledge, information and belief at the date of its publication. The information given is designed only as a guidance for safe handling, use, processing, storage, transportation, disposal and release and is not to be considered a warranty or quality specification. The information relates only to the specific material designated and may not be valid for such material used in combination with any other materials or in any process, unless specified in the text.

Revision Information

Product and Company Identification: Product Uses
Composition / Information on Ingredients: Ingredients
Physical & Chemical Properties: Multiple Properties
Ecological Information: Ecotox Property Data
Transport Information: Proper Shipping Name/Packing Group
Regulatory Information: United States
HazReg Data: North America
GHS: Classification



SAFETY DATA SHEET

1. Identification

Product identifier	LPS® All Purpose Anti-Seize
Other means of identification	
Part Number	04108, 04110, 04105
Recommended use	An all-purpose, anti-seize lubricant designed to prevent seizure and galling and resist settling and hardening of welding.
Recommended restrictions	None known.
Manufacturer/Importer/Supplier/Distributor information	
Manufacturer	
Manufacturer	
Company name	LPS Laboratories, a division of Illinois Tool Works, Inc.
Address	4647 Hugh Howell Rd. Tucker, GA 30084 (U.S.A.)
Country	(U.S.A.)
In Case of Emergency	Tel: +1 770-243-8800 1-800-424-9300 (inside U.S.) +001 703-527-3887 (outside U.S.)
Website	www.lpslabs.com
E-mail	sds@lpslabs.com

2. Hazard(s) identification

Physical hazards	Not classified.
Health hazards	Not classified.
Environmental hazards	Not classified.
OSHA defined hazards	Not classified.
Label elements	
Hazard symbol	None.
Signal word	None.
Hazard statement	The mixture does not meet the criteria for classification.
Precautionary statement	
Prevention	Observe good industrial hygiene practices.
Response	Wash hands after handling.
Storage	Store away from incompatible materials.
Disposal	Dispose of waste and residues in accordance with local authority requirements.
Hazard(s) not otherwise classified (HNOC)	None known.
Supplemental information	None.

3. Composition/information on ingredients

Mixtures

Chemical name	Common name and synonyms	CAS number	%
Molybdenum (IV) sulfide		1317-33-5	1 - 5
Zinc oxide		1314-13-2	1 - 2

4. First-aid measures

Inhalation	Move to fresh air. Call a physician if symptoms develop or persist.
Skin contact	Wash off with soap and water. Get medical attention if irritation develops and persists.
Eye contact	Rinse with water. Get medical attention if irritation develops and persists.

Material name: LPS® All Purpose Anti-Seize
818 Version #: 01 Issue date: 11-12-2014

SDS US
1 / 6

Ingestion	Rinse mouth. Get medical attention if symptoms occur.
Most important symptoms/effects, acute and delayed	Direct contact with eyes may cause temporary irritation. Exposed individuals may experience eye tearing, redness, and discomfort.
Indication of immediate medical attention and special treatment needed	Treat symptomatically.
General information	Ensure that medical personnel are aware of the material(s) involved, and take precautions to protect themselves.

5. Fire-fighting measures

Suitable extinguishing media	Water fog. Foam. Dry chemical powder. Carbon dioxide (CO ₂).
Unsuitable extinguishing media	Do not use a solid water stream as it may scatter and spread fire.
Specific hazards arising from the chemical	During fire, gases hazardous to health may be formed.
Special protective equipment and precautions for firefighters	Self-contained breathing apparatus and full protective clothing must be worn in case of fire.
Fire fighting equipment/instructions	Use water spray to cool unopened containers.
Specific methods	Use standard firefighting procedures and consider the hazards of other involved materials.
General fire hazards	No unusual fire or explosion hazards noted.

6. Accidental release measures

Personal precautions, protective equipment and emergency procedures	Keep unnecessary personnel away. Do not touch damaged containers or spilled material unless wearing appropriate protective clothing. Use personal protection recommended in Section 8 of the SDS.
Methods and materials for containment and cleaning up	Stop the flow of material, if this is without risk. Prevent entry into waterways, sewer, basements or confined areas. Following product recovery, flush area with water. For waste disposal, see section 13 of the SDS.
Environmental precautions	Avoid discharge into drains, water courses or onto the ground.

7. Handling and storage

Precautions for safe handling	Avoid prolonged exposure. Observe good industrial hygiene practices.
Conditions for safe storage, including any incompatibilities	Store in original tightly closed container. Store away from incompatible materials (see Section 10 of the SDS).

8. Exposure controls/personal protection

Occupational exposure limits

US. OSHA Table Z-1 Limits for Air Contaminants (29 CFR 1910.1000)

Components	Type	Value	Form
Zinc Oxide (CAS 1314-13-2)	PEL	5 mg/m ³	Fume.
		5 mg/m ³	Respirable fraction.
		15 mg/m ³	Total dust.

US. ACGIH Threshold Limit Values

Components	Type	Value	Form
Zinc Oxide (CAS 1314-13-2)	STEL	10 mg/m ³	Respirable fraction.
	TWA	2 mg/m ³	Respirable fraction.

US. NIOSH: Pocket Guide to Chemical Hazards

Components	Type	Value	Form
Zinc Oxide (CAS 1314-13-2)	Ceiling	15 mg/m ³	Dust.
	STEL	10 mg/m ³	Fume.
	TWA	5 mg/m ³	Dust.
		5 mg/m ³	Fume.

Biological limit values No biological exposure limits noted for the ingredient(s).

Material name: LPS® All Purpose Anti-Seize
818 Version #: 01 Issue date: 11-12-2014

SDS US
2 / 6

Appropriate engineering controls	Good general ventilation (typically 10 air changes per hour) should be used. Ventilation rates should be matched to conditions. If applicable, use process enclosures, local exhaust ventilation, or other engineering controls to maintain airborne levels below recommended exposure limits. If exposure limits have not been established, maintain airborne levels to an acceptable level.
Individual protection measures, such as personal protective equipment	
Eye/face protection	Wear safety glasses with side shields (or goggles).
Skin protection	
Hand protection	Wear appropriate chemical resistant gloves.
Other	Wear suitable protective clothing.
Respiratory protection	In case of insufficient ventilation, wear suitable respiratory equipment.
Thermal hazards	Wear appropriate thermal protective clothing, when necessary.
General hygiene considerations	Always observe good personal hygiene measures, such as washing after handling the material and before eating, drinking, and/or smoking. Routinely wash work clothing and protective equipment to remove contaminants.

9. Physical and chemical properties

Appearance	Paste.
Physical state	Solid.
Form	Solid.
Color	Dark grey.
Odor	Hydrocarbon-like.
Odor threshold	Not available.
pH	Not available.
Melting point/freezing point	500 °F (260 °C)
Initial boiling point and boiling range	> 600.8 °F (> 316 °C)
Flash point	> 429.8 °F (> 221.0 °C)
Evaporation rate	Not available.
Flammability (solid, gas)	Not available.
Upper/lower flammability or explosive limits	
Flammability limit - lower (%)	Not available.
Flammability limit - upper (%)	Not available.
Explosive limit - lower (%)	Not available.
Explosive limit - upper (%)	Not available.
Vapor pressure	Not available.
Vapor density	Not available.
Relative density	Not available.
Solubility(ies)	
Solubility (water)	Insoluble
Partition coefficient (n-octanol/water)	Not available.
Auto-ignition temperature	Not available.
Decomposition temperature	Not available.
Viscosity	Not available.
Other information	
Specific gravity	1.19
VOC (Weight %)	Negligible

10. Stability and reactivity

Reactivity	The product is stable and non-reactive under normal conditions of use, storage and transport.
Chemical stability	Material is stable under normal conditions.

Possibility of hazardous reactions	Hazardous polymerization does not occur.
Conditions to avoid	Heat, flames and sparks.
Incompatible materials	Strong oxidizing agents.
Hazardous decomposition products	No hazardous decomposition products are known.

11. Toxicological information

Information on likely routes of exposure

Inhalation	No adverse effects due to inhalation are expected.
Skin contact	Frequent or prolonged contact may defat and dry the skin, leading to discomfort and dermatitis.
Eye contact	Direct contact with eyes may cause temporary irritation.
Ingestion	May cause discomfort if swallowed. However, ingestion is not likely to be a primary route of occupational exposure.

Symptoms related to the physical, chemical and toxicological characteristics
 Direct contact with eyes may cause temporary irritation. Exposure may cause temporary irritation, redness, or discomfort.

Information on toxicological effects

Acute toxicity
 Expected to be a low hazard for usual industrial or commercial handling by trained personnel.

Components	Species	Test Results
Zinc oxide (CAS 1314-13-2)		
Acute		
<i>Inhalation</i>		
LC50	Mouse	> 5.7 mg/l, 4 Hours
	Rat	> 5700 mg/m3
<i>Oral</i>		
LD50	Mouse	2000 - 5000 mg/kg
	Rat	> 5 g/kg
<i>Other</i>		
LD50	Rat	240 mg/kg

Skin corrosion/irritation
 Prolonged skin contact may cause temporary irritation.

Serious eye damage/eye irritation
 Direct contact with eyes may cause temporary irritation.

Respiratory or skin sensitization

Respiratory sensitization	Not a respiratory sensitizer.
Skin sensitization	This product is not expected to cause skin sensitization.

Germ cell mutagenicity
 No data available to indicate product or any components present at greater than 0.1% are mutagenic or genotoxic.

Carcinogenicity
 This product is not considered to be a carcinogen by IARC, ACGIH, NTP, or OSHA.

OSHA Specifically Regulated Substances (29 CFR 1910.1001-1050)

Not listed.

Reproductive toxicity
 This product is not expected to cause reproductive or developmental effects.

Specific target organ toxicity - single exposure
 Not classified.

Specific target organ toxicity - repeated exposure
 Not classified.

Aspiration hazard
 Not likely, due to the form of the product.

Chronic effects
 None known.

Further information
 This product has no known adverse effect on human health.

12. Ecological information

Ecotoxicity
 The product is not classified as environmentally hazardous. However, this does not exclude the possibility that large or frequent spills can have a harmful or damaging effect on the environment.

Components	Species	Test Results
Zinc oxide (CAS 1314-13-2)		
Aquatic		
Fish	LC50 Fathead minnow (<i>Pimephales promelas</i>)	2246 mg/l, 96 hours
Persistence and degradability	No data is available on the degradability of this product.	
Bioaccumulative potential	No data available.	
Mobility in soil	No data available.	
Other adverse effects	None known.	
13. Disposal considerations		
Disposal instructions	Collect and reclaim or dispose in sealed containers at licensed waste disposal site.	
Local disposal regulations	Dispose in accordance with all applicable regulations.	
Hazardous waste code	The waste code should be assigned in discussion between the user, the producer and the waste disposal company.	
Waste from residues / unused products	Dispose of in accordance with local regulations. Empty containers or liners may retain some product residues. This material and its container must be disposed of in a safe manner (see: Disposal instructions).	
Contaminated packaging	Empty containers should be taken to an approved waste handling site for recycling or disposal. Since emptied containers may retain product residue, follow label warnings even after container is emptied.	

14. Transport information**DOT**

Not regulated as dangerous goods.

IATA

Not regulated as dangerous goods.

IMDG

Not regulated as dangerous goods.

Transport in bulk according to Annex II of MARPOL 73/78 and the IBC Code Not applicable.

15. Regulatory information

US federal regulations All components are on the U.S. EPA TSCA Inventory List. This product is not known to be a "Hazardous Chemical" as defined by the OSHA Hazard Communication Standard, 29 CFR 1910.1200.

TSCA Section 12(b) Export Notification (40 CFR 707, Subpt. D)

Not regulated.

CERCLA Hazardous Substance List (40 CFR 302.4)

Not listed.

SARA 304 Emergency release notification

Not regulated.

OSHA Specifically Regulated Substances (29 CFR 1910.1001-1050)

Not listed.

Superfund Amendments and Reauthorization Act of 1986 (SARA)

Hazard categories Immediate Hazard - No
Delayed Hazard - No
Fire Hazard - No
Pressure Hazard - No
Reactivity Hazard - No

SARA 302 Extremely hazardous substance

Not listed.

SARA 311/312 Hazardous chemical No

SARA 313 (TRI reporting)

Not regulated.

Other federal regulations

Clean Air Act (CAA) Section 112 Hazardous Air Pollutants (HAPs) List

Not regulated.

Clean Air Act (CAA) Section 112(r) Accidental Release Prevention (40 CFR 68.130)

Not regulated.

Safe Drinking Water Act (SDWA)

Not regulated.

US state regulations

US. California Controlled Substances. CA Department of Justice (California Health and Safety Code Section 11100)

Not listed.

US. Massachusetts RTK - Substance List

Molybdenum (IV) sulfide (CAS 1317-33-5)

Zinc oxide (CAS 1314-13-2)

US. New Jersey Worker and Community Right-to-Know Act

Zinc oxide (CAS 1314-13-2)

US. Pennsylvania Worker and Community Right-to-Know Law

Zinc oxide (CAS 1314-13-2)

US. Rhode Island RTK

Not regulated.

US. California Proposition 65

California Safe Drinking Water and Toxic Enforcement Act of 1986 (Proposition 65): This material is not known to contain any chemicals currently listed as carcinogens or reproductive toxins.

International Inventories

Country(s) or region	Inventory name	On inventory (yes/no)*
Australia	Australian Inventory of Chemical Substances (AICS)	No
Canada	Domestic Substances List (DSL)	Yes
Canada	Non-Domestic Substances List (NDSL)	No
China	Inventory of Existing Chemical Substances in China (IECSC)	Yes
Europe	European Inventory of Existing Commercial Chemical Substances (EINECS)	Yes
Europe	European List of Notified Chemical Substances (ELINCS)	No
Japan	Inventory of Existing and New Chemical Substances (ENCS)	No
Korea	Existing Chemicals List (ECL)	No
New Zealand	New Zealand Inventory	Yes
Philippines	Philippine Inventory of Chemicals and Chemical Substances (PICCS)	Yes
United States & Puerto Rico	Toxic Substances Control Act (TSCA) Inventory	Yes

*A "Yes" indicates that all components of this product comply with the inventory requirements administered by the governing country(s)

A "No" indicates that one or more components of the product are not listed or exempt from listing on the inventory administered by the governing country(s).

16. Other information, including date of preparation or last revision

Issue date 11-12-2014

Version # 01

Disclaimer LPS Laboratories cannot anticipate all conditions under which this information and its product, or the products of other manufacturers in combination with its product, may be used. It is the user's responsibility to ensure safe conditions for handling, storage and disposal of the product, and to assume liability for loss, injury, damage or expense due to improper use. The information provided in this Safety Data Sheet is correct to the best of our knowledge, information and belief at the date of its publication. The information given is designed only as a guidance for safe handling, use, processing, storage, transportation, disposal and release and is not to be considered a warranty or quality specification. The information relates only to the specific material designated and may not be valid for such material used in combination with any other materials or in any process, unless specified in the text.

SAFETY DATA SHEET

SECTION 1 PRODUCT AND COMPANY IDENTIFICATION

PRODUCT

Product Name: MOBIL VACTRA OIL HEAVY MEDIUM
Product Description: Base Oil and Additives
Product Code: 201560503060, 580407-00, 970015
Intended Use: Lubricant

COMPANY IDENTIFICATION

Supplier: EXXON MOBIL CORPORATION
 22777 Springwoods Village Parkway
 Spring, TX. 77389 USA
24 Hour Health Emergency 609-737-4411
Transportation Emergency Phone 800-424-9300 or 703-527-3887 CHEMTREC
Product Technical Information 800-662-4525
MSDS Internet Address <http://www.exxon.com>, <http://www.mobil.com>

SECTION 2 HAZARDS IDENTIFICATION

This material is not hazardous according to regulatory guidelines (see (M)SDS Section 15).

Other hazard information:

HAZARD NOT OTHERWISE CLASSIFIED (HNOC): None as defined under 29 CFR 1910.1200.

PHYSICAL / CHEMICAL HAZARDS

No significant hazards.

HEALTH HAZARDS

High-pressure injection under skin may cause serious damage. Excessive exposure may result in eye, skin, or respiratory irritation.

ENVIRONMENTAL HAZARDS

No significant hazards.

NFPA Hazard ID:	Health: 0	Flammability: 1	Reactivity: 0
HMIS Hazard ID:	Health: 0	Flammability: 1	Reactivity: 0

NOTE: This material should not be used for any other purpose than the intended use in Section 1 without expert advice. Health studies have shown that chemical exposure may cause potential human health risks which may vary from person to person.

SECTION 3	COMPOSITION / INFORMATION ON INGREDIENTS
------------------	---

This material is defined as a mixture.

Hazardous Substance(s) or Complex Substance(s) required for disclosure

Name	CAS#	Concentration*	GHS Hazard Codes
2,6-DITERTBUTYL PHENOL	128-39-2	0.1 - < 0.25%	H315, H319(2A), H400(M factor 1), H410(M factor 1)

* All concentrations are percent by weight unless material is a gas. Gas concentrations are in percent by volume.

As per paragraph (i) of 29 CFR 1910.1200, formulation is considered a trade secret and specific chemical identity and exact percentage (concentration) of composition may have been withheld. Specific chemical identity and exact percentage composition will be provided to health professionals, employees, or designated representatives in accordance with applicable provisions of paragraph (i).

SECTION 4	FIRST AID MEASURES
------------------	---------------------------

INHALATION

Remove from further exposure. For those providing assistance, avoid exposure to yourself or others. Use adequate respiratory protection. If respiratory irritation, dizziness, nausea, or unconsciousness occurs, seek immediate medical assistance. If breathing has stopped, assist ventilation with a mechanical device or use mouth-to-mouth resuscitation.

SKIN CONTACT

Wash contact areas with soap and water. If product is injected into or under the skin, or into any part of the body, regardless of the appearance of the wound or its size, the individual should be evaluated immediately by a physician as a surgical emergency. Even though initial symptoms from high pressure injection may be minimal or absent, early surgical treatment within the first few hours may significantly reduce the ultimate extent of injury.

EYE CONTACT

Flush thoroughly with water. If irritation occurs, get medical assistance.

INGESTION

First aid is normally not required. Seek medical attention if discomfort occurs.

SECTION 5	FIRE FIGHTING MEASURES
------------------	-------------------------------

EXTINGUISHING MEDIA

Appropriate Extinguishing Media: Use water fog, foam, dry chemical or carbon dioxide (CO₂) to extinguish flames.

Inappropriate Extinguishing Media: Straight Streams of Water

FIRE FIGHTING

Fire Fighting Instructions: Evacuate area. Prevent runoff from fire control or dilution from entering streams, sewers, or drinking water supply. Firefighters should use standard protective equipment and in enclosed spaces, self-contained breathing apparatus (SCBA). Use water spray to cool fire exposed surfaces and to protect personnel.

Hazardous Combustion Products: Smoke, Fume, Sulfur oxides, Aldehydes, Oxides of carbon, Incomplete combustion products

FLAMMABILITY PROPERTIES

Flash Point [Method]: >204°C (399°F) [ASTM D-92]

Flammable Limits (Approximate volume % in air): LEL: 0.9 UEL: 7.0

Autoignition Temperature: N/D

SECTION 6

ACCIDENTAL RELEASE MEASURES

NOTIFICATION PROCEDURES

In the event of a spill or accidental release, notify relevant authorities in accordance with all applicable regulations. US regulations require reporting releases of this material to the environment which exceed the applicable reportable quantity or oil spills which could reach any waterway including intermittent dry creeks. The National Response Center can be reached at (800)424-8802.

PROTECTIVE MEASURES

Avoid contact with spilled material. See Section 5 for fire fighting information. See the Hazard Identification Section for Significant Hazards. See Section 4 for First Aid Advice. See Section 8 for advice on the minimum requirements for personal protective equipment. Additional protective measures may be necessary, depending on the specific circumstances and/or the expert judgment of the emergency responders.

For emergency responders: Respiratory protection: respiratory protection will be necessary only in special cases, e.g., formation of mists. Half-face or full-face respirator with filter(s) for dust/organic vapor or Self Contained Breathing Apparatus (SCBA) can be used depending on the size of spill and potential level of exposure. If the exposure cannot be completely characterized or an oxygen deficient atmosphere is possible or anticipated, SCBA is recommended. Work gloves that are resistant to hydrocarbons are recommended. Gloves made of polyvinyl acetate (PVA) are not water-resistant and are not suitable for emergency use. Chemical goggles are recommended if splashes or contact with eyes is possible. Small spills: normal antistatic work clothes are usually adequate. Large spills: full body suit of chemical resistant, antistatic material is recommended.

SPILL MANAGEMENT

Land Spill: Stop leak if you can do it without risk. Recover by pumping or with suitable absorbent.

Water Spill: Stop leak if you can do it without risk. Confine the spill immediately with booms. Warn other shipping. Remove from the surface by skimming or with suitable absorbents. Seek the advice of a specialist before using dispersants.

Water spill and land spill recommendations are based on the most likely spill scenario for this material; however, geographic conditions, wind, temperature, (and in the case of a water spill) wave and current direction and speed may greatly influence the appropriate action to be taken. For this reason, local experts should be consulted. Note: Local regulations may prescribe or limit action to be taken.

ENVIRONMENTAL PRECAUTIONS

Large Spills: Dike far ahead of liquid spill for later recovery and disposal. Prevent entry into waterways,

sewers, basements or confined areas.

SECTION 7	HANDLING AND STORAGE
------------------	-----------------------------

HANDLING

Prevent small spills and leakage to avoid slip hazard. Material can accumulate static charges which may cause an electrical spark (ignition source). When the material is handled in bulk, an electrical spark could ignite any flammable vapors from liquids or residues that may be present (e.g., during switch-loading operations). Use proper bonding and/or ground procedures. However, bonding and grounds may not eliminate the hazard from static accumulation. Consult local applicable standards for guidance. Additional references include American Petroleum Institute 2003 (Protection Against Ignitions Arising out of Static, Lightning and Stray Currents) or National Fire Protection Agency 77 (Recommended Practice on Static Electricity) or CENELEC CLC/TR 50404 (Electrostatics - Code of practice for the avoidance of hazards due to static electricity).

Static Accumulator: This material is a static accumulator.

STORAGE

The container choice, for example storage vessel, may effect static accumulation and dissipation. Do not store in open or unlabelled containers. Keep away from incompatible materials.

SECTION 8	EXPOSURE CONTROLS / PERSONAL PROTECTION
------------------	--

Exposure limits/standards for materials that can be formed when handling this product: When mists/aerosols can occur the following are recommended: 5 mg/m³ - ACGIH TLV (inhalable fraction), 5 mg/m³ - OSHA PEL.

NOTE: Limits/standards shown for guidance only. Follow applicable regulations.

No biological limits allocated.

ENGINEERING CONTROLS

The level of protection and types of controls necessary will vary depending upon potential exposure conditions. Control measures to consider:

No special requirements under ordinary conditions of use and with adequate ventilation.

PERSONAL PROTECTION

Personal protective equipment selections vary based on potential exposure conditions such as applications, handling practices, concentration and ventilation. Information on the selection of protective equipment for use with this material, as provided below, is based upon intended, normal usage.

Respiratory Protection: If engineering controls do not maintain airborne contaminant concentrations at a level which is adequate to protect worker health, an approved respirator may be appropriate. Respirator selection, use, and maintenance must be in accordance with regulatory requirements, if applicable. Types of respirators to be considered for this material include:

No special requirements under ordinary conditions of use and with adequate ventilation.

For high airborne concentrations, use an approved supplied-air respirator, operated in positive pressure mode. Supplied air respirators with an escape bottle may be appropriate when oxygen levels are inadequate, gas/vapor warning properties are poor, or if air purifying filter capacity/rating may be exceeded.

Hand Protection: Any specific glove information provided is based on published literature and glove manufacturer data. Glove suitability and breakthrough time will differ depending on the specific use conditions. Contact the glove manufacturer for specific advice on glove selection and breakthrough times for your use conditions. Inspect and replace worn or damaged gloves. The types of gloves to be considered for this material include:

No protection is ordinarily required under normal conditions of use.

Eye Protection: If contact is likely, safety glasses with side shields are recommended.

Skin and Body Protection: Any specific clothing information provided is based on published literature or manufacturer data. The types of clothing to be considered for this material include:

No skin protection is ordinarily required under normal conditions of use. In accordance with good industrial hygiene practices, precautions should be taken to avoid skin contact.

Specific Hygiene Measures: Always observe good personal hygiene measures, such as washing after handling the material and before eating, drinking, and/or smoking. Routinely wash work clothing and protective equipment to remove contaminants. Discard contaminated clothing and footwear that cannot be cleaned. Practice good housekeeping.

ENVIRONMENTAL CONTROLS

Comply with applicable environmental regulations limiting discharge to air, water and soil. Protect the environment by applying appropriate control measures to prevent or limit emissions.

SECTION 9	PHYSICAL AND CHEMICAL PROPERTIES
------------------	---

Note: Physical and chemical properties are provided for safety, health and environmental considerations only and may not fully represent product specifications. Contact the Supplier for additional information.

GENERAL INFORMATION

Physical State: Liquid
Color: Amber
Odor: Characteristic
Odor Threshold: N/D

IMPORTANT HEALTH, SAFETY, AND ENVIRONMENTAL INFORMATION

Relative Density (at 15 °C): 0.882
Flammability (Solid, Gas): N/A
Flash Point [Method]: >204°C (399°F) [ASTM D-92]
Flammable Limits (Approximate volume % in air): LEL: 0.9 UEL: 7.0
Autoignition Temperature: N/D
Boiling Point / Range: > 316°C (600°F)
Decomposition Temperature: N/D
Vapor Density (Air = 1): > 2 at 101 kPa
Vapor Pressure: < 0.013 kPa (0.1 mm Hg) at 20 °C
Evaporation Rate (n-butyl acetate = 1): N/D

pH: N/A
Log Pow (n-Octanol/Water Partition Coefficient): > 3.5
Solubility in Water: Negligible
Viscosity: >68 cSt (68 mm²/sec) at 40 °C
Oxidizing Properties: See Hazards Identification Section.

OTHER INFORMATION

Freezing Point: N/D
Melting Point: N/A
Pour Point: -15°C (5°F)
DMSO Extract (mineral oil only), IP-346: < 3 %wt

SECTION 10	STABILITY AND REACTIVITY
-------------------	---------------------------------

REACTIVITY: See sub-sections below.

STABILITY: Material is stable under normal conditions.

CONDITIONS TO AVOID: Excessive heat. High energy sources of ignition.

MATERIALS TO AVOID: Strong oxidizers

HAZARDOUS DECOMPOSITION PRODUCTS: Material does not decompose at ambient temperatures.

POSSIBILITY OF HAZARDOUS REACTIONS: Hazardous polymerization will not occur.

SECTION 11	TOXICOLOGICAL INFORMATION
-------------------	----------------------------------

INFORMATION ON TOXICOLOGICAL EFFECTS

Hazard Class	Conclusion / Remarks
Inhalation	
Acute Toxicity: No end point data for material.	Minimally Toxic. Based on assessment of the components.
Irritation: No end point data for material.	Negligible hazard at ambient/normal handling temperatures.
Ingestion	
Acute Toxicity: No end point data for material.	Minimally Toxic. Based on assessment of the components.
Skin	
Acute Toxicity: No end point data for material.	Minimally Toxic. Based on assessment of the components.
Skin Corrosion/Irritation: No end point data for material.	Negligible irritation to skin at ambient temperatures. Based on assessment of the components.
Eye	
Serious Eye Damage/Irritation: No end point data for material.	May cause mild, short-lasting discomfort to eyes. Based on assessment of the components.
Sensitization	
Respiratory Sensitization: No end point data for material.	Not expected to be a respiratory sensitizer.
Skin Sensitization: No end point data for material.	Not expected to be a skin sensitizer. Based on assessment of the components.
Aspiration: Data available.	Not expected to be an aspiration hazard. Based on

	physico-chemical properties of the material.
Germ Cell Mutagenicity: No end point data for material.	Not expected to be a germ cell mutagen. Based on assessment of the components.
Carcinogenicity: No end point data for material.	Not expected to cause cancer. Based on assessment of the components.
Reproductive Toxicity: No end point data for material.	Not expected to be a reproductive toxicant. Based on assessment of the components.
Lactation: No end point data for material.	Not expected to cause harm to breast-fed children.
Specific Target Organ Toxicity (STOT)	
Single Exposure: No end point data for material.	Not expected to cause organ damage from a single exposure.
Repeated Exposure: No end point data for material.	Not expected to cause organ damage from prolonged or repeated exposure. Based on assessment of the components.

OTHER INFORMATION

Contains:

Base oil severely refined: Not carcinogenic in animal studies. Representative material passes IP-346, Modified Ames test, and/or other screening tests. Dermal and inhalation studies showed minimal effects; lung non-specific infiltration of immune cells, oil deposition and minimal granuloma formation. Not sensitizing in test animals.

The following ingredients are cited on the lists below: None.

--REGULATORY LISTS SEARCHED--

1 = NTP CARC	3 = IARC 1	5 = IARC 2B
2 = NTP SUS	4 = IARC 2A	6 = OSHA CARC

SECTION 12 ECOLOGICAL INFORMATION

The information given is based on data available for the material, the components of the material, and similar materials.

ECOTOXICITY

Material -- Not expected to be harmful to aquatic organisms.

MOBILITY

Base oil component -- Low solubility and floats and is expected to migrate from water to the land. Expected to partition to sediment and wastewater solids.

PERSISTENCE AND DEGRADABILITY

Biodegradation:

Base oil component -- Expected to be inherently biodegradable

BIOACCUMULATION POTENTIAL

Base oil component -- Has the potential to bioaccumulate, however metabolism or physical properties may reduce the bioconcentration or limit bioavailability.

SECTION 13	DISPOSAL CONSIDERATIONS
-------------------	--------------------------------

Disposal recommendations based on material as supplied. Disposal must be in accordance with current applicable laws and regulations, and material characteristics at time of disposal.

DISPOSAL RECOMMENDATIONS

Product is suitable for burning in an enclosed controlled burner for fuel value or disposal by supervised incineration at very high temperatures to prevent formation of undesirable combustion products. Protect the environment. Dispose of used oil at designated sites. Minimize skin contact. Do not mix used oils with solvents, brake fluids or coolants.

REGULATORY DISPOSAL INFORMATION

RCRA Information: The unused product, in our opinion, is not specifically listed by the EPA as a hazardous waste (40 CFR, Part 261D), nor is it formulated to contain materials which are listed as hazardous wastes. It does not exhibit the hazardous characteristics of ignitability, corrosivity or reactivity and is not formulated with contaminants as determined by the Toxicity Characteristic Leaching Procedure (TCLP). However, used product may be regulated.

Empty Container Warning Empty Container Warning (where applicable): Empty containers may contain residue and can be dangerous. Do not attempt to refill or clean containers without proper instructions. Empty drums should be completely drained and safely stored until appropriately reconditioned or disposed. Empty containers should be taken for recycling, recovery, or disposal through suitably qualified or licensed contractor and in accordance with governmental regulations. **DO NOT PRESSURISE, CUT, WELD, BRAZE, SOLDER, DRILL, GRIND, OR EXPOSE SUCH CONTAINERS TO HEAT, FLAME, SPARKS, STATIC ELECTRICITY, OR OTHER SOURCES OF IGNITION. THEY MAY EXPLODE AND CAUSE INJURY OR DEATH.**

SECTION 14	TRANSPORT INFORMATION
-------------------	------------------------------

LAND (DOT): Not Regulated for Land Transport

LAND (TDG): Not Regulated for Land Transport

SEA (IMDG): Not Regulated for Sea Transport according to IMDG-Code

Marine Pollutant: No

AIR (IATA): Not Regulated for Air Transport

SECTION 15	REGULATORY INFORMATION
-------------------	-------------------------------

OSHA HAZARD COMMUNICATION STANDARD: This material is not considered hazardous in accordance with OSHA HazCom 2012, 29 CFR 1910.1200.

Listed or exempt from listing/notification on the following chemical inventories: AICS, DSL, IECSC, TSCA

EPCRA SECTION 302: This material contains no extremely hazardous substances.

SARA (311/312) REPORTABLE HAZARD CATEGORIES: None.

SARA (313) TOXIC RELEASE INVENTORY: This material contains no chemicals subject to the supplier notification requirements of the SARA 313 Toxic Release Program.

The following ingredients are cited on the lists below: None.

--REGULATORY LISTS SEARCHED--

1 = ACGIH ALL	6 = TSCA 5a2	11 = CA P65 REPRO	16 = MN RTK
2 = ACGIH A1	7 = TSCA 5e	12 = CA RTK	17 = NJ RTK
3 = ACGIH A2	8 = TSCA 6	13 = IL RTK	18 = PA RTK
4 = OSHA Z	9 = TSCA 12b	14 = LA RTK	19 = RI RTK
5 = TSCA 4	10 = CA P65 CARC	15 = MI 293	

Code key: CARC=Carcinogen; REPRO=Reproductive

SECTION 16	OTHER INFORMATION
------------	-------------------

N/D = Not determined, N/A = Not applicable

KEY TO THE H-CODES CONTAINED IN SECTION 3 OF THIS DOCUMENT (for information only):

H315: Causes skin irritation; Skin Corr/Irritation, Cat 2

H319(2A): Causes serious eye irritation; Serious Eye Damage/Irr, Cat 2A

H400: Very toxic to aquatic life; Acute Env Tox, Cat 1

H410: Very toxic to aquatic life with long lasting effects; Chronic Env Tox, Cat 1

THIS SAFETY DATA SHEET CONTAINS THE FOLLOWING REVISIONS:

Updates made in accordance with implementation of GHS requirements.

 The information and recommendations contained herein are, to the best of ExxonMobil's knowledge and belief, accurate and reliable as of the date issued. You can contact ExxonMobil to insure that this document is the most current available from ExxonMobil. The information and recommendations are offered for the user's consideration and examination. It is the user's responsibility to satisfy itself that the product is suitable for the intended use. If buyer repackages this product, it is the user's responsibility to insure proper health, safety and other necessary information is included with and/or on the container. Appropriate warnings and safe-handling procedures should be provided to

handlers and users. Alteration of this document is strictly prohibited. Except to the extent required by law, re-publication or retransmission of this document, in whole or in part, is not permitted. The term, "ExxonMobil" is used for convenience, and may include any one or more of ExxonMobil Chemical Company, Exxon Mobil Corporation, or any affiliates in which they directly or indirectly hold any interest.

Internal Use Only
MHC: 0B, 0B, 0, 0, 0, 0 PPEC: A
DGN: 2006644XUS (1017266)

Copyright 2002 Exxon Mobil Corporation, All rights reserved

SAF-T-LOK

International Corporation

Material Safety Data Sheet

SAF-T-EZE MOLY GRADE ANTI-SEIZE

Issue Date: 10/30/14

SECTION I - PRODUCT AND COMPANY INFORMATION

Product Name: MOLY GRADE ANTI-SEIZE
 Product Type: Lubricating Grease
 Part Numbers: **80855, 80837, 80822, 80878, 80853, 6V-4876**
 Hazard Rating: Health: 1 Fire: 1 Reactivity: 0

Company Identification: SAF-T-LOK International Corporation
 300 EISENHOWER LANE NORTH
 LOMBARD, IL 60148

Contact: Chris Michaels
 Telephone/ Fax: (630) 495-2001
 Emergency Phone (24 Hour): (703) 527-3887
 Chemtrec (24 Hour): (800) 424-9300, (703) 527-3887
 Preparer: Ind. Hygiene Department
 Internet: www.saftlok.com

Product Class: Mixture
 DOT Hazard Class: N/A
 Shipping Name: Unrestricted

SECTION II - INGREDIENT AND HAZARD INFORMATION

Components	CAS Number	Percent
Graphite	7782-42-5	20 - 30
Hydrotreated Heavy Napthenic Distillate	64742-52-5	40 - 50
Molybdenum Disulfide	1317-33-5	20 - 30

SECTION III - HAZARD IDENTIFICATION AND EMERGENCY OVERVIEWEMERGENCY OVERVIEW

Physical appearance:	Paste	<u>HMIS</u>	
Physical color:	Black	Health:	1
Odor:	Mild / Inoffensive	Flammability:	1
		Reactivity:	0
		Personal Protection:	B

WARNING;

**MAY CAUSE: EYE IRRITATION
 SKIN IRRITATION
 RESPIRATORY TRACT IRRITATION
 MAY IRRITATE EXISTING ALLERGIC SKIN CONDITIONS**

Relative routes of entry: Skin, Inhalation, Eyes, Ingestion

Skin Contact: Usually no effect, however, as with any chemical, prolonged, excessive, or repeated exposure may cause mild to moderate skin irritation, exhibited by redness, drying and cracking of unprotected skin.

Eye Contact: May irritate with slight pain and redness.

Respiratory/ Inhalation: Usually none, however, as with any chemical product, some irritation may occur.

Ingestion: Amounts transferred to mouth by fingers, etc, during normal operation should not cause injury.

Medical conditions generally aggravated by exposure: None known, however any chemical product may enhance allergies already present in certain individuals.

This product does not require exceptional labeling due to the evaluation procedure of the "General Classification guideline for preparations of the EU".

SECTION IV – FIRST AID INSTRUCTIONS

Skin Contact: Remove contaminated clothing. Wash affected area with soap and rinse with plenty of water. Get medical attention if symptoms occur. Wash clothing before reuse.

Eye Contact: Flush with water for at least 15 minutes holding eyelid open. Get medical attention if symptoms persist.

Respiratory / Inhalation: Remove to fresh air, if symptoms develop get medical attention.

Ingestion: Do not induce vomiting. Obtain medical attention if symptoms develop.

SECTION V – FIRE FIGHTING INSTRUCTIONS

Flash Point:	360°F (C.O.C.)
Unusual Fire and Explosion Hazards:	None
Flammable Limits:	LEL: N/A, UEL: N/A
Extinguishing Media:	Carbon Dioxide, Foam, Dry Chemicals
Fire Fighting Procedures:	Air mask and procedures for fighting chemical fires. Do not inhale gases.

SECTION VI - ACCIDENTAL RELEASE MEASURES

Special Precautions: None known. Follow general precautions shown below.

Environmental precautions: Prevent material from entering floor drains, sewers, or any bodies of water.

Clean up methods: Scoop up into waste container or soak up with absorbent material. Store in a closed container until disposal. Dispose of material according to regulations.

SECTION VII - HANDLING AND STORAGE

Handling: No special precautions necessary if used properly. Avoid contact with eyes, skin, and clothing. Avoid breathing vapors. Wash hands thoroughly at mealtime and end of shift.

Storage: Isolated storage facility/ warehouse not required. Store in a cool, dry location (60-90°F) in a well-ventilated area in original container. Keep container tightly closed when not in use.

Personal Protection: Wear personal protective equipment as outlined in Section VIII of this MSDS.

SECTION VIII – EXPOSURE CONTROLS AND PERSONAL PROTECTION

Respiratory Protection: No respiratory protection required, but normal good ventilation is recommended. Forced ventilation may be required if concentrations exceed normal use exposure.

Skin Protection: Not required, but if desired, use impermeable gloves (neoprene, butyl rubber, natural rubber), as necessary to avoid skin contact, as well as proper clothing or plastic apron. Wash hands before eating, drinking, or using restroom.

Eye Protection: Not required if application method is proper. Avoid contact with eyes.

Eye Washes: Eye wash stations should be located within 100 feet or 10 second walk of the work area.

SECTION IX - PHYSICAL AND CHEMICAL PROPERTIES

Physical state:	Paste
Color:	Black
Odor:	Mild/ Inoffensive
Boiling Point:	600°F (316°C)
Melting Point	Not determined
Flash Point	360°F
Self-inflammability	Is not self-igniting
Explosion danger	Not explosive
Specific Gravity:	1.4
Vapor Density (Air = 1):	N/D
Vapor Pressure (mm Hg.):	< 0.1 @70°F
pH:	Not determined
Evaporation Rate:	Not determined
Solubility in Water:	Insoluble
VOC (Organic solvents)	0.1%
Percent Solids:	50

SECTION X –STABILITY AND REACTIVITY

Stability:	Stable
Hazardous Polymerization:	Will not occur
Hazardous decomposition byproducts:	None if used and stored according to specifications
Conditions to avoid	Strong oxidizing agents

SECTION XI – TOXICOLOGICAL INFORMATION

No harmful effects have been determined if product is used and handled according to specifications.

This product is not subject to classification according to the calculation method of the General EC Classification Guidelines for Preparations.

Sensitization	None known
Eye Irritant	Not determined
Skin Irritant	Not determined
Carcinogen	No

SECTION XII – ECOLOGICAL DATA

Water Hazard: Do not allow entry into drains or surface water
Class 2 per German Regulation

SECTION XIII – DISPOSAL CONSIDERATIONS

Recommended method of disposal: Small quantities can be disposed with normal household waste.
Disposal must be made according to official regulations.

EPA Hazardous Waste Number; Not an RCRA hazardous waste.

SECTION XIV – SHIPPING AND TRANSPORTATION INFORMATION

U.S. Department of Transportation Ground (49 CFR

Proper Shipping Name: Unrestricted
Hazard Class or Division: None
Identification Number: None
Packing Group: None

International Air Transportation (OCAO/IATA):

Proper Shipping Name: Unrestricted
Hazard Class or Division: None
Identification Number: None
Packing Group: None

Water Transportation (IMO/IMDG):

Proper Shipping Name: Environmentally hazardous substance, liquid, N.O. S.
Hazard Class or Division: IMDG Class 9
Identification Number: None
Packing Group: None
Marine Pollutant: Yes

ADR/RID-GGVS/E Class (cross border) Unrestricted

SECTION XV – REGULATORY INFORMATIONUnited States Regulatory Information

TSCA 8 (b) Inventory Status: All components are listed or are exempt from listing on the Toxic Substances Control Act Inventory

Canada Regulatory Information

CEPA DSL/NDSL Status: All components are listed on or are exempt from listing on the Domestic Substances List.

SECTION XVI – OTHER INFORMATION

Revision date: 10/30/14
By: Human Resource Department

DISCLAIMER: The information on this material safety data sheet represents our current data and best opinion as to the proper use in handling of this product under normal conditions. Any use of the product which is not in conformance with this data sheet or which involves using the product in combination with any other product or any other process is the responsibility of the user. SAF-T-LOK International Corporation specifically disclaims all warranties, express or implied, including warranties of merchantability and fitness for a particular purpose, arising from sale or use of SAF-T-LOK International Corporation products.

Page 4 of 4

Product: Moly Anti-Seize

Product Name: Nook Industries E-900L Liquid
(Part number NLU-1004)
Revision Date: 23 Sept 2013
Page 1 of 7



MATERIAL SAFETY DATA SHEET

SECTION 1 PRODUCT AND COMPANY IDENTIFICATION

PRODUCT

Product Name: Nook Industries E-900L Ball Screw Lubricant Liquid
Product Description: Synthetic Base Stocks and Additives
Product Code: 202050401020, 494237-00, 971870
Intended Use: Ball screw lubrication

COMPANY IDENTIFICATION

Supplier: **NOOK INDUSTRIES**
 4950 EAST 49th STREET
 CLEVELAND, OH 44125

24 Hour Health Emergency 800-255-3924
MSDS Requests 800-321-7800
MSDS Internet Address <http://www.nookindustries.com/r/msds>

SECTION 2 COMPOSITION / INFORMATION ON INGREDIENTS

REPORTABLE HAZARDOUS SUBSTANCE(S) OR COMPLEX SUBSTANCE(S)

NAME	CAS#	CONCENTRATION*
1-NAPHTHYLAMINE, N-PHENYL-	90-30-2	1%

* All concentrations are percent by weight unless material is a gas. Gas concentrations are in percent by volume.

SECTION 3 HAZARDS IDENTIFICATION

This material is not considered to be hazardous according to regulatory guidelines (see (MSDS Section 15).

POTENTIAL HEALTH EFFECTS

Excessive exposure may result in eye, skin, or respiratory irritation. This product is not expected to produce adverse health effects under normal conditions of use and with appropriate personal hygiene practices. Product may decompose at elevated temperatures or under fire conditions and give off irritating and/or harmful (carbon monoxide) gases/vapors/fumes. Symptoms from acute exposure to these decomposition products in confined spaces may include headache, nausea, eye, nose, and throat irritation. High-pressure injection under skin may cause serious damage.

NFPA HAZARD ID:	HEALTH: 1	FLAMMABILITY: 1	REACTIVITY: 0
HMIS Hazard ID:	Health: 1	Flammability: 1	Reactivity: 0

NOTE: This material should not be used for any other purpose than the intended use in Section 1 without expert advice. Health studies have shown that chemical exposure may cause potential human health risks which may vary from person to person.

Product Name: Nook Industries E-900L Liquid
(Part number NLU-1004)
Revision Date: 23 Sept 2013
Page 2 of 7



SECTION 4 FIRST AID MEASURES

INHALATION

Remove from further exposure. For those providing assistance, avoid exposure to yourself or others. Use adequate respiratory protection. If respiratory irritation, dizziness, nausea, or unconsciousness occurs, seek immediate medical assistance. If breathing has stopped, assist ventilation with a mechanical device or use mouth-to-mouth resuscitation.

SKIN CONTACT

Wash contact areas with soap and water. If product is injected into or under the skin, or into any part of the body, regardless of the appearance of the wound or its size, the individual should be evaluated immediately by a physician as a surgical emergency. Even though initial symptoms from high pressure injection may be minimal or absent, early surgical treatment within the first few hours may significantly reduce the ultimate extent of injury.

EYE CONTACT

Flush thoroughly with water. If irritation occurs, get medical assistance.

INGESTION

Seek immediate medical attention.

SECTION 5 FIRE FIGHTING MEASURES

EXTINGUISHING MEDIA

Appropriate Extinguishing Media: Use water fog, foam, dry chemical or carbon dioxide (CO₂) to extinguish flames.

Inappropriate Extinguishing Media: Straight Streams of Water

FIRE FIGHTING

Fire Fighting Instructions: Evacuate area. Prevent runoff from fire control or dilution from entering streams, sewers, or drinking water supply. Firefighters should use standard protective equipment and in enclosed spaces, self-contained breathing apparatus (SCBA). Use water spray to cool fire exposed surfaces and to protect personnel.

Hazardous Combustion Products: Aldehydes, Smoke, Fume, Oxides of carbon, Sulfur oxides, Incomplete combustion products, Trimethylol propane phosphate

FLAMMABILITY PROPERTIES

Flash Point [Method]: 210C (410F) [ASTM D-92]

Flammable Limits (Approx vol % in air): LEL: N/D UEL: N/D

Autoignition Temperature: N/D

Product Name: Nook Industries E-900L Liquid
(Part number NLU-1004)
Revision Date: 23 Sept 2013
Page 3 of 7



SECTION 6 ACCIDENTAL RELEASE MEASURES

NOTIFICATION PROCEDURES

In the event of a spill or accidental release, notify relevant authorities in accordance with all applicable regulations. US regulations require reporting releases of this material to the environment which exceed the applicable reportable quantity or oil spills which could reach any waterway including intermittent dry creeks. The National Response Center can be reached at (800)424-8802.

SPILL MANAGEMENT

Land Spill: Stop leak if you can do it without risk. Recover by pumping or with suitable absorbent.

Water Spill: Stop leak if you can do it without risk. Confine the spill immediately with booms. Warn other shipping. Remove from the surface by skimming or with suitable absorbents. Seek the advice of a specialist before using dispersants.

Water spill and land spill recommendations are based on the most likely spill scenario for this material; however, geographic conditions, wind, temperature, (and in the case of a water spill) wave and current direction and speed may greatly influence the appropriate action to be taken. For this reason, local experts should be consulted. Note: Local regulations may prescribe or limit action to be taken.

ENVIRONMENTAL PRECAUTIONS

Large Spills: Dike far ahead of liquid spill for later recovery and disposal. Prevent entry into waterways, sewers, basements or confined areas.

SECTION 7 HANDLING AND STORAGE

HANDLING

It has been determined that during fires neurotoxic trimethylol propane phosphate may be formed, which when inhaled may impair central nervous system function. In addition, thermally decomposed (and cooled) residues may be neurotoxic. Prevent small spills and leakage to avoid slip hazard.

Static Accumulator: This material is a static accumulator.

STORAGE

Do not store in open or unlabelled containers.

SECTION 8 EXPOSURE CONTROLS / PERSONAL PROTECTION

NOTE: Limits/standards shown for guidance only. Follow applicable regulations.

ENGINEERING CONTROLS

The level of protection and types of controls necessary will vary depending upon potential exposure conditions. Control measures to consider:

No special requirements under ordinary conditions of use and with adequate ventilation.

PERSONAL PROTECTION

Personal protective equipment selections vary based on potential exposure conditions such as applications, handling practices, concentration and ventilation. Information on the selection of protective equipment for use with this material, as provided below, is based upon intended, normal usage.

Product Name: Nook Industries E-900L Liquid
(Part number NLU-1004)
Revision Date: 23 Sept 2013
Page 4 of 7



Respiratory Protection: If engineering controls do not maintain airborne contaminant concentrations at a level which is adequate to protect worker health, an approved respirator may be appropriate. Respirator selection, use, and maintenance must be in accordance with regulatory requirements, if applicable. Types of respirators to be considered for this material include:

No special requirements under ordinary conditions of use and with adequate ventilation.

For high airborne concentrations, use an approved supplied-air respirator, operated in positive pressure mode. Supplied air respirators with an escape bottle may be appropriate when oxygen levels are inadequate, gas/vapor warning properties are poor, or if air purifying filter capacity/rating may be exceeded.

Hand Protection: Any specific glove information provided is based on published literature and glove manufacturer data. Glove suitability and breakthrough time will differ depending on the specific use conditions. Contact the glove manufacturer for specific advice on glove selection and breakthrough times for your use conditions. Inspect and replace worn or damaged gloves. The types of gloves to be considered for this material include:

No protection is ordinarily required under normal conditions of use.

Eye Protection: If contact is likely, safety glasses with side shields are recommended.

Skin and Body Protection: Any specific clothing information provided is based on published literature or manufacturer data. The types of clothing to be considered for this material include:

No skin protection is ordinarily required under normal conditions of use. In accordance with good industrial hygiene practices, precautions should be taken to avoid skin contact.

Specific Hygiene Measures: Always observe good personal hygiene measures, such as washing after handling the material and before eating, drinking, and/or smoking. Routinely wash work clothing and protective equipment to remove contaminants. Discard contaminated clothing and footwear that cannot be cleaned. Practice good housekeeping.

ENVIRONMENTAL CONTROLS

See Sections 6, 7, 12, 13.

SECTION 9 PHYSICAL AND CHEMICAL PROPERTIES

Typical physical and chemical properties are given below. Consult the Supplier in Section 1 for additional data.

GENERAL INFORMATION

Physical State:	Liquid
Color:	Amber
Odor:	Characteristic
Odor Threshold:	N/D

IMPORTANT HEALTH, SAFETY, AND ENVIRONMENTAL INFORMATION

Relative Density (at 15 C):	0.96
Flash Point [Method]:	210C (410F) [ASTM D-92]
Flammable Limits (Approx vol % in air):	LEL: N/D UEL: N/D
Autoignition Temperature:	N/D
Boiling Point / Range:	> 316C (600F)
Vapor Density (Air = 1):	N/D
Vapor Pressure:	< 0.013 kPa (0.1 mm Hg) at 20 C
Evaporation Rate (n-butyl acetate = 1):	N/D
pH:	N/A

Product Name: Nook Industries E-900L Liquid
(Part number NLU-1004)
Revision Date: 23 Sept 2013
Page 5 of 7



Log Pow (n-Octanol/Water Partition Coefficient): N/A
Solubility in Water: Negligible
Viscosity: 13.3 cSt (13.3 mm²/sec) at 40 C | 3 cSt (3 mm²/sec) at 100C
Oxidizing Properties: See Sections 3, 15, 16.

OTHER INFORMATION

Freezing Point: N/D
Melting Point: N/A
Pour Point: -62°C (-80°F)

SECTION 10 STABILITY AND REACTIVITY

Stability: material is stable under normal conditions.
Conditions To Avoid: excessive heat. High energy sources of ignition.
Materials To Avoid: Strong oxidizers
Hazardous Decomposition Products: material does not decompose at ambient temperatures.
Hazardous Polymerization: will not occur.

SECTION 11 TOXICOLOGICAL INFORMATION

ACUTE TOXICITY

ROUTE OF EXPOSURE	CONCLUSION / REMARKS
Inhalation	
Toxicity: No end point data.	Not determined.
Irritation: No end point data.	Negligible hazard at ambient/normal handling temperatures. Based on assessment of the components.
Ingestion	
Toxicity: No end point data.	Minimally Toxic. Based on assessment of the components.
Skin	
Toxicity: No end point data.	Minimally Toxic. Based on assessment of the components.
Irritation: No end point data.	Negligible irritation to skin at ambient temperatures. Based on assessment of the components.
Eye	
Irritation: No end point data.	May cause mild, short-lasting discomfort to eyes. Based on assessment of the components.

CHRONIC/OTHER EFFECTS

Contains:

N-phenyl-1-naphthylamine: A single oral overexposure may lead to signs of cyanosis, including headache, shallow respiration, dizziness, confusion, fall in blood pressure, convulsions, coma, jaundice.

Product Name: Nook Industries E-900L Liquid
(Part number NLU-1004)
Revision Date: 23 Sept 2013
Page 6 of 7



Anemia may occur later. Repeated exposure in laboratory animals caused liver and kidney damage and depression of bone marrow activity. Hematuria may occur due to bladder and kidney irritation. Genotoxic in vitro.

Phenyl-alpha-naphthylamine (PAN): Undiluted PAN is a skin sensitizer. Human testing with lubricants containing 1.0% PAN caused no reactions indicative of sensitization.

Additional information is available by request.

The following ingredients are cited on the lists below: None.

--REGULATORY LISTS SEARCHED--		
1 = NTP CARC	3 = IARC 1	5 = IARC 2B
2 = NTP SUS	4 = IARC 2A	6 = OSHA CARC

SECTION 12 ECOLOGICAL INFORMATION

The information given is based on data available for the material, the components of the material, and similar materials.

ECOTOXICITY

Material -- Not expected to be harmful to aquatic organisms.

Material -- Not expected to demonstrate chronic toxicity to aquatic organisms.

SECTION 13 DISPOSAL CONSIDERATIONS

Disposal recommendations based on material as supplied. Disposal must be in accordance with current applicable laws and regulations, and material characteristics at time of disposal.

DISPOSAL RECOMMENDATIONS

Dispose of waste at an appropriate treatment & disposal facility in accordance with applicable laws and regulations, and product characteristics at time of disposal.

REGULATORY DISPOSAL INFORMATION

RCRA Information: The unused product, in our opinion, is not specifically listed by the EPA as a hazardous waste (40 CFR, Part 261D), nor is it formulated to contain materials which are listed as hazardous wastes. It does not exhibit the hazardous characteristics of ignitability, corrosivity or reactivity and is not formulated with contaminants as determined by the Toxicity Characteristic Leaching Procedure (TCLP). However, used product may be regulated.

Empty Container Warning Empty Container Warning (where applicable): Empty containers may contain residue and can be dangerous. Do not attempt to refill or clean containers without proper instructions. Empty drums should be completely drained and safely stored until appropriately reconditioned or disposed. Empty containers should be taken for recycling, recovery, or disposal through suitably qualified or licensed contractor and in accordance with governmental regulations. DO NOT PRESSURISE, CUT, WELD, BRAZE, SOLDER, DRILL, GRIND, OR EXPOSE SUCH CONTAINERS TO HEAT, FLAME, SPARKS, STATIC ELECTRICITY, OR OTHER SOURCES OF IGNITION. THEY MAY EXPLODE AND CAUSE INJURY OR DEATH.

Product Name: Nook Industries E-900L Liquid
(Part number NLU-1004)
Revision Date: 23 Sept 2013
Page 7 of 7



SECTION 14 TRANSPORT INFORMATION

LAND (DOT) : Not Regulated for Land Transport
LAND (TDG) : Not Regulated for Land Transport
SEA (IMDG) : Not Regulated for Sea Transport according to IMDG-Code
AIR (IATA) : Not Regulated for Air Transport

SECTION 15 REGULATORY INFORMATION

OSHA HAZARD COMMUNICATION STANDARD: When used for its intended purposes, this material is not classified as hazardous in accordance with OSHA 29 CFR 1910.1200.

NATIONAL CHEMICAL INVENTORY LISTING: PICCS, AICS, KECI, TSCA, EINECS

EPCRA: This material contains no extremely hazardous substances.

SARA (311/312) REPORTABLE HAZARD CATEGORIES: None.

SARA (313) TOXIC RELEASE INVENTORY: This material contains no chemicals subject to the supplier notification requirements of the SARA 313 Toxic Release Program.

The Following Ingredients are Cited on the Lists Below:

CHEMICAL NAME	CAS NUMBER	LIST CITATIONS
Diphenylamine	122-39-4	5

--REGULATORY LISTS SEARCHED--			
1 = ACGIH ALL	6 = TSCA 5a2	11 = CA P65 REPRO	16 = MN RTK
2 = ACGIH A1	7 = TSCA 5e	12 = CA RTK	17 = NJ RTK
3 = ACGIH A2	8 = TSCA 6	13 = IL RTK	18 = PA RTK
4 = OSHA Z	9 = TSCA 12b	14 = LA RTK	19 = RI RTK
5 = TSCA 4	10 = CA P65 CARC	15 = MI 293	

Code key: CARC=Carcinogen; REPRO=Reproductive

SECTION 16 OTHER INFORMATION

N/D = Not determined, N/A = Not applicable

###

The information and recommendations contained herein are, to the best of Nook Industries' knowledge and belief, accurate and reliable as of the date issued. You can contact Nook Industries to insure that this document is the most current available from Nook Industries. The information and recommendations are offered for the user's consideration and examination. It is the user's responsibility to satisfy itself that the product is suitable for the intended use. If buyer repackages this product, it is the user's responsibility to insure proper health, safety and other necessary information is included with and/or on the container. Appropriate warnings and safe-handling procedures should be provided to handlers and users. Alteration of this document is strictly prohibited. Except to the extent required by law, re-publication or retransmission of this document, in whole or in part, is not permitted.

Product Name: Nook Industries PAG-1 Grease
(Part number NLU-1001)
Revision Date: 23 Sept 2013
Page 1 of 8



MATERIAL SAFETY DATA SHEET

SECTION 1 PRODUCT AND COMPANY IDENTIFICATION

PRODUCT

Product Name: Omniguard
MSDS Number: 778589
Intended Use: Lubricating Grease

COMPANY IDENTIFICATION

Supplier Nook Industries
4950 East 49th Street
Cleveland, Oh 44125

24 Health Emergency: Chemtrec: 800-424-9300 (24 Hours)
MSDS Requests 800-321-7800
MSDS Internet Address <http://www.nookindustries.com/r/msds>

SECTION 2 HAZARDS IDENTIFICATION

EMERGENCY OVERVIEW

Appearance: Tan
Physical Form: Semi-Solid
Odor: Petroleum

POTENTIAL HEALTH EFFECTS

Eye: Eye irritant. Contact may cause stinging, watering, redness, and swelling.
Skin: Contact may cause mild skin irritation including redness and a burning sensation. Repeated exposure may cause skin dryness or cracking. No information available on skin absorption.
Inhalation (Breathing): No information available on acute toxicity. Inhalation is not an expected route of exposure.
Ingestion (Swallowing): Low degree of toxicity by ingestion.
Signs and Symptoms: Inhalation of oil mists or vapors generated at elevated temperatures may cause respiratory irritation. Accidental ingestion can result in minor irritation of the digestive tract, nausea and diarrhea.
Pre-Existing Medical Conditions: Conditions which may be aggravated by exposure include eye disorders and skin disorders.

See Section 11 for additional Toxicity Information.

SECTION 3 COMPOSITION / INFORMATION ON INGREDIENTS

COMPONENT	CASRN	CONCENTRATION ¹
Lubricant Base Oil (Petroleum)	VARIOUS	50 - 80
Additives	PROPRIETARY	15 - 40
Calcium Dodecylbenzenesulfonate	26264-06-2	1 - 3

¹ All concentrations are percent by weight unless ingredient is a gas. Gas concentrations are in percent by volume.

Product Name: Nook Industries PAG-1 Grease
(Part number NLU-1001)
Revision Date: 23 Sept 2013
Page 2 of 8



SECTION 4 FIRST AID MEASURES

Eye Contact: For direct contact, remove contact lenses if present and easy to do. Immediately hold eyelids apart and flush the affected eye(s) with clean water for at least 15 minutes. Seek immediate medical attention.

Skin Contact: Remove contaminated shoes and clothing and cleanse affected area(s) thoroughly by washing with mild soap and water or a waterless hand cleaner. If irritation or redness develops and persists, seek medical attention. If product is injected into or under the skin, or into any part of the body, regardless of the appearance of the wound or its size, the individual should be evaluated immediately by a physician. (see Note to Physician)

Inhalation (Breathing): If respiratory symptoms develop, move victim away from source of exposure and into fresh air in a position comfortable for breathing. If symptoms persist, seek medical attention.

Ingestion (Swallowing): First aid is not normally required; however, if swallowed and symptoms develop, seek medical attention.

Notes to Physician: High-pressure hydrocarbon injection injuries may produce substantial necrosis of underlying tissue despite an innocuous appearing external wound. These injuries often require extensive emergency surgical debridement and all injuries should be evaluated by a specialist in order to assess the extent of injury. Early surgical treatment within the first few hours may significantly reduce the ultimate extent of injury.

SECTION 5 FIRE-FIGHTING MEASURES

NFPA 704 Hazard Class

Health:	1
Flammability:	1
Instability:	0

(0-Minimal, 1-Slight, 2-Moderate, 3-Serious, 4-Severe)

Unusual Fire & Explosion Hazards: This material may burn, but will not ignite readily. If container is not properly cooled, it can rupture in the heat of a fire.

Extinguishing Media: Dry chemical, carbon dioxide, foam, or water spray is recommended. Water or foam may cause frothing of materials heated above 212°F / 100°C. Carbon dioxide can displace oxygen. Use caution when applying carbon dioxide in confined spaces. Simultaneous use of foam and water on the same surface is to be avoided as water destroys the foam.

Fire Fighting Instructions: For fires beyond the initial stage, emergency responders in the immediate hazard area should wear protective clothing. When the potential chemical hazard is unknown, in enclosed or confined spaces, a self contained breathing apparatus should be worn. In addition, wear other appropriate protective equipment as conditions warrant (see Section 8).

Isolate immediate hazard area and keep unauthorized personnel out. Stop spill/release if it can be done safely. Move undamaged containers from immediate hazard area if it can be done safely. Water spray may be useful in minimizing or dispersing vapors and to protect personnel. Cool equipment exposed to fire with water, if it can be done safely. Avoid spreading burning liquid with water used for cooling purposes.

Hazardous Combustion Products: Combustion may yield smoke, carbon monoxide, and other products of incomplete combustion.

Oxides of sulfur, nitrogen or phosphorus may also be formed.

See Section 9 for Flammable Properties including Flash Point and Flammable (Explosive) Limits



SECTION 6 ACCIDENTAL RELEASE MEASURES

Personal Precautions: This material may burn, but will not ignite readily. Keep all sources of ignition away from spill/release. Stay upwind and away from spill/release. Avoid direct contact with material. For large spillages, notify persons down wind of the spill/release, isolate immediate hazard area and keep unauthorized personnel out. Wear appropriate protective equipment, including respiratory protection, as conditions warrant (see Section 8). See Sections 2 and 7 for additional information on hazards and precautionary measures.

Environmental Precautions: If spill/release in excess of EPA reportable quantity (see Section 15) is made into the environment, immediately notify the National Response Center (phone number 800-424-8802). Stop spill/release if it can be done safely. Prevent spilled material from entering sewers, storm drains, other unauthorized drainage systems, and natural waterways. Use water sparingly to minimize environmental contamination and reduce disposal requirements. If spill occurs on water notify appropriate authorities and advise shipping of any hazard. Spills into or upon navigable waters, the contiguous zone, or adjoining shorelines that cause a sheen or discoloration on the surface of the water, may require notification of the National Response Center (phone number 800-424-8802).

Methods for Containment and Clean-Up: Notify relevant authorities in accordance with all applicable regulations. Immediate cleanup of any spill is recommended. Dike far ahead of spill for later recovery or disposal. Absorb spill with inert material such as sand or vermiculite, and place in suitable container for disposal. If spilled on water remove with appropriate methods (e.g. skimming, booms or absorbents). In case of soil contamination, remove contaminated soil for remediation or disposal, in accordance with local regulations.

SECTION 7 HANDLING AND STORAGE

Precautions for safe handling: Keep away from flames and hot surfaces. Wear eye/face protection. Wash thoroughly after handling.

Use good personal hygiene practices and wear appropriate personal protective equipment.

High pressure injection of hydrocarbon fuels, hydraulic oils or greases under the skin may have serious consequences even though no symptoms or injury may be apparent. This can happen accidentally when using high pressure equipment such as high pressure grease guns, fuel injection apparatus or from pinhole leaks in tubing of high pressure hydraulic oil equipment.

Do not enter confined spaces such as tanks or pits without following proper entry procedures such as ASTM D-4276 and 29CFR 1910.146. Do not wear contaminated clothing or shoes.

Conditions for safe storage: Keep container(s) tightly closed and properly labeled. Use and store this material in cool, dry, well-ventilated area away from heat and all sources of ignition. Store only in approved containers. Keep away from any incompatible material (see Section 10). Protect container(s) against physical damage.

"Empty" containers retain residue and may be dangerous. Do not pressurize, cut, weld, braze, solder, drill, grind, or expose such containers to heat, flame, sparks, or other sources of ignition. They may explode and cause injury or death. "Empty" drums should be completely drained, properly bunged, and promptly shipped to the supplier or a drum reconditioner. All containers should be disposed of in an environmentally safe manner and in accordance with governmental regulations. Before working on or in tanks which contain or have contained this material, refer to OSHA regulations, ANSI Z49.1, and other references pertaining to cleaning, repairing, welding, or other contemplated operations.

Product Name: Nook Industries PAG-1 Grease
(Part number NLU-1001)
Revision Date: 23 Sept 2013
Page 4 of 8



SECTION 8 EXPOSURE CONTROLS / PERSONAL PROTECTION

COMPONENT	US-ACGIH	OSHA	OTHER
Lubricant Base Oil (Petroleum)	TWA: 5mg/m ³ STEL: 10 mg/m ³ as Oil Mist, if generated	TWA: 5 mg/m ³ as Oil Mist, if generated	---

NOTE: State, local or other agencies or advisory groups may have established more stringent limits. Consult an industrial hygienist or similar professional, or your local agencies, for further information.

Engineering controls: If current ventilation practices are not adequate to maintain airborne concentrations below the established exposure limits, additional engineering controls may be required.

Eye/Face Protection: The use of eye protection that meets or exceeds ANSI Z.87.1 is recommended to protect against potential eye contact, irritation, or injury. Depending on conditions of use, a face shield may be necessary.

Skin/Hand Protection: The use of gloves impervious to the specific material handled is advised to prevent skin contact. Users should check with manufacturers to confirm the breakthrough performance of their products. Suggested protective materials: Nitrile

Respiratory Protection: Respiratory protection is not normally required under intended conditions of use. Emergencies or conditions that could result in significant airborne exposures may require the use of NIOSH approved respiratory protection. An industrial hygienist or other appropriate health and safety professional should be consulted for specific guidance under these situations.

Other Protective Equipment: Eye wash and quick-drench shower facilities should be available in the work area. Thoroughly clean shoes and wash contaminated clothing before reuse.

Suggestions provided in this section for exposure control and specific types of protective equipment are based on readily available information. Users should consult with the specific manufacturer to confirm the performance of their protective equipment. Specific situations may require consultation with industrial hygiene, safety, or engineering professionals.

SECTION 9 PHYSICAL AND CHEMICAL PROPERTIES

NOTE: Unless otherwise stated, values are determined at 20°C (68°F) and 760 mm Hg (1 atm). Data represent typical values and are not intended to be specifications.

Appearance:	Tan
Physical Form:	Semi-Solid
Odor:	Petroleum
Odor Threshold:	No data
pH:	Not applicable
Vapor Pressure:	<0.1 mm Hg
Vapor Density (air=1):	> 5
Initial Boiling Point/Range:	No data
Melting/Freezing Point:	No data
Solubility in Water:	Insoluble
Solubility in Other Solvents:	Soluble
Partition Coefficient (n-octanol/water) (Kow):	No data
Specific Gravity (water=1):	0.9943 @ 60°F (15.6°C)
Bulk Density:	8.29 lbs/gal

Product Name: Nook Industries PAG-1 Grease
(Part number NLU-1001)
Revision Date: 23 Sept 2013
Page 5 of 8



Evaporation Rate (nBuAc=1): <1
Flash Point: 464°F / 240°C
Test Method: Cleveland Open Cup (COC), ASTM D92
Lower Explosive Limits (vol % in air): No data
Upper Explosive Limits (vol % in air): No data
Auto-ignition Temperature: No data

SECTION 10 STABILITY AND REACTIVITY

Stability: Stable under normal ambient and anticipated conditions of use.

Conditions to Avoid: Extended exposure to high temperatures can cause decomposition. Avoid all possible sources of ignition.

Materials to Avoid (Incompatible Materials): Avoid contact with strong oxidizing agents and strong reducing agents.

Hazardous Decomposition Products: Not anticipated under normal conditions of use.

Hazardous Polymerization: Not known to occur.

SECTION 11 TOXICOLOGICAL INFORMATION

CHRONIC TOXICITY:

Lubricant Base Oil (Petroleum)

Carcinogenicity: The petroleum base oils contained in this product have been highly refined by a variety of processes including severe hydrocracking/hydroprocessing to reduce aromatics and improve performance characteristics. All of the oils meet the IP-346 criteria of less than 3 percent PAH's and are not considered carcinogens by NTP, IARC, or OSHA.

ACUTE TOXICITY:

COMPONENT	ORAL LD50	DERMAL LD50	INHALATION LC50
Lubricant Base Oil (Petroleum)	> 5 g/kg	> 2 g/kg	> 5 mg/L
Calcium Dodecylbenzenesulfonate	1,300 mg/kg	No data	No data

SECTION 12 ECOLOGICAL INFORMATION

Ecotoxicity: Experimental studies show that acute aquatic toxicity values are greater than 1000 mg/l. These values are consistent with the predicted aquatic toxicity of these substances based on their hydrocarbon compositions. However, there is insufficient information available on the toxicity of the thickening agents used in greases. Should therefore be regarded as capable of causing long term adverse effects in the aquatic environment.

Mobility: Volatilization to air is not expected to be a significant fate process due to the low vapor pressure of this material.

Components may behave differently in the aquatic environment with soaps dispersing and dissolving to some extent in water while the hydrocarbons will float on the surface due to their low water solubility. The hydrocarbon portion would be expected to show low mobility in soil and water. The major environmental fate would be expected to be biodegradation.

Product Name: Nook Industries PAG-1 Grease
(Part number NLU-1001)
Revision Date: 23 Sept 2013
Page 6 of 8



Persistence and degradability: The base oil constituents of greases are expected to be inherently, but no readily biodegradable.

Some of the thickening agents may be readily biodegradable.

Bioaccumulation Potential: Log Kow values measured for the hydrocarbon components of this material range from 4 to over 6, and therefore regarded as having the potential to bioaccumulate. In practice, metabolic processes may reduce bioconcentration.

SECTION 13 DISPOSAL CONSIDERATIONS

The generator of a waste is always responsible for making proper hazardous waste determinations and needs to consider state and local requirements in addition to federal regulations.

This material, if discarded as produced, would not be a federally regulated RCRA "listed" hazardous waste and is not believed to exhibit characteristics of hazardous waste. See Sections 7 and 8 for information on handling, storage and personal protection and Section 9 for physical/chemical properties. It is possible that the material as produced contains constituents which are not required to be listed in the MSDS but could affect the hazardous waste determination. Additionally, use which results in chemical or physical change of this material could subject it to regulation as a hazardous waste.

This material under most intended uses would become "Used Oil" due to contamination by physical or chemical impurities. Whenever possible, Recycle Used Oil in accordance with applicable federal and state or local regulations. Container contents should be completely used and containers should be emptied prior to discard.

SECTION 14 TRANSPORTATION INFORMATION

U.S. DEPARTMENT OF TRANSPORTATION (DOT)

Shipping Description: Not regulated

NOTE: If shipped by land in a packaging having a capacity of 3,500 gallons or more, the provisions of 49 CFR, Part 130 apply. (Contains oil)

INTERNATIONAL MARITIME DANGEROUS GOODS (IMDG)

Shipping Description: Not regulated

NOTE: U.S. DOT compliance requirements may apply. See 49 CFR 171.22, 23 & 25.

INTERNATIONAL CIVIL AVIATION ORG.

INTERNATIONAL AIR TRANSPORT ASSOC. (ICAO/IATA)

UN/ID #: Not regulated

NOTE: U.S. DOT compliance requirements may apply. See 49 CFR 171.22, 23 & 24.

	LTD. QTY	PASSENGER AIRCRAFT	CARGO AIRCRAFT ONLY
Packaging Instruction #:	---	---	---
Max. Net Qty. Per Package:	---	---	---
Packaging Instruction # after 12/31/2010:			

Product Name: Nook Industries PAG-1 Grease
(Part number NLU-1001)
Revision Date: 23 Sept 2013
Page 7 of 8



SECTION 15 REGULATORY INFORMATION

CERCLA/SARA

Section 302 Extremely Hazardous Substances and TPOs (in pounds):

This material does not contain any chemicals subject to the reporting requirements of SARA 302 and 40 CFR 372.

CERCLA/SARA

Section 311/312 (Title III Hazard Categories)

Acute Health: Yes
Chronic Health: No
Fire Hazard: No
Pressure Hazard: No
Reactive Hazard: No

COMPONENT	RQ
Calcium Dodecylbenzenesulfonate	1000 lb

CALIFORNIA PROPOSITION 65

WARNING: This material may contain detectable quantities of the following chemicals, known to the State of California to cause cancer, birth defects or other reproductive harm, and which may be subject to the requirements of California Proposition 65 (CA Health & Safety Code Section 25249.5):

COMPONENT	TYPE OF TOXICITY
1-Naphthylamine	Cancer
2-Naphthylamine	Cancer

CANADIAN REGULATIONS

This product has been classified in accordance with the hazard criteria of the Controlled Products Regulations (CPR) and the MSDS contains all the information required by the Regulations.

WHMIS Hazard Class D2B

NATIONAL CHEMICAL INVENTORIES:

All components are either listed on the USTSCA Inventory, or are not regulated under TSCA.

All components are either on the DSL, or are exempt from DSL listing requirements.

U.S. Export Control Classification Number: EAR99

Product Name: Nook Industries PAG-1 Grease
(Part number NLU-1001)
Revision Date: 23 Sept 2013
Page 8 of 8



SECTION 16 OTHER INFORMATION

Date of Issue:	06-Aug-2010
Status:	FINAL
Previous Issue Date:	27-Aug-2007
MSDS Number:	778589

Guide to Abbreviations:

ACGIH = American Conference of Governmental Industrial Hygienists

CASRN = Chemical Abstracts Service Registry Number

CEILING = Ceiling Limit (15 minutes)

CERCLA = The Comprehensive Environmental Response, Compensation, and Liability Act

EPA = Environmental Protection Agency

IARC = International Agency for Research on Cancer

LEL = Lower Explosive Limit

NE = Not Established

NFPA = National Fire Protection Association

NTP = National Toxicology Program

OSHA = Occupational Safety and Health Administration

PEL = Permissible Exposure Limit (OSHA)

SARA = Superfund Amendments and Reauthorization Act

STEL = Short Term Exposure Limit (15 minutes)

TLV = Threshold Limit Value (ACGIH)

TWA = Time Weighted Average (8 hours)

UEL = Upper Explosive Limit

WHMIS = Worker Hazardous Materials Information System (Canada)



MATERIAL SAFETY DATA SHEET

76 Unax AW 32, 46, 68

1. PRODUCT AND COMPANY IDENTIFICATION

Product Name: 76 Unax AW 32, 46, 68
Product Code: 4641032000, 4642046000, 4643068000
Synonyms: 76 Unax AW 32
 76 Unax AW 46
 76 Unax AW 68
Intended Use: Industrial oil
Chemical Family: Petroleum hydrocarbon
Responsible Party: 76 Lubricants
 A Division of ConocoPhillips
 600 N. Dairy Ashford
 Houston, TX 77079-1175
For Additional MSDSs 800-762-0942
Technical Information: 800-435-7761

The intended use of this product is indicated above. If any additional use is known, please contact us at the Technical Information number listed.

EMERGENCY OVERVIEW

24 Hour Emergency Telephone Numbers:

Spill, Leak, Fire or Accident California Poison Control System: (800) 356-3129
 Call CHEMTREC
 North America: (800)424-9300
 Others: (703)527-3887 (collect)

Health Hazards/Precautionary Measures: Avoid contact with eyes, skin and clothing. Wash thoroughly after handling.

Physical Hazards/Precautionary Measures: Keep away from all sources of ignition.

Appearance: Clear and bright
Physical form: Liquid
Odor: Mild petroleum

NFPA Hazard Class:

Health: 1 (Slight)
 Flammability: 1 (Slight)
 Reactivity: 0 (Least)

HMIS Hazard Class

Health: 1 (Slight)
 Flammability: 1 (Slight)
 Physical Hazard: 0 (Least)

2. COMPOSITION/INFORMATION ON INGREDIENTS

<u>HAZARDOUS COMPONENTS</u>	<u>% WEIGHT</u>	<u>EXPOSURE GUIDELINE</u>		
		<u>Limits</u>	<u>Agency</u>	<u>Type</u>
Zinc Compound CAS# Proprietary	<1	Not Established		

(MSDS: 722330)

Page 2 of 7

<u>OTHER COMPONENTS</u>	<u>% WEIGHT</u>	<u>EXPOSURE GUIDELINE</u>		
		<u>Limits</u>	<u>Agency</u>	<u>Type</u>
Lubricant Base Oil (Petroleum) CAS# Various	>99	(See: Oil Mist, If Generated)		
Additives CAS# Proprietary	<1	Not Established		

<u>REFERENCE</u>	<u>EXPOSURE GUIDELINE</u>		
	<u>Limits</u>	<u>Agency</u>	<u>Type</u>
Oil Mist, If Generated	5 mg/m3	ACGIH	TWA
CAS# None	10 mg/m3	ACGIH	STEL
	5 mg/m3	OSHA	TWA
	2500 mg/m3	NIOSH	IDLH
	5 mg/m3	NOHSC	TWA

The base oil for this product can be a mixture of any of the following highly refined petroleum streams:
CAS 64741-88-4; CAS 64741-89-5; CAS 64741-96-4; CAS 64741-97-5; CAS 64742-01-4; CAS 64742-52-5; CAS
64742-53-6; CAS 64742-54-7; CAS 64742-55-8; CAS 64742-56-9; CAS 64742-57-0; CAS 64742-62-7; CAS
64742-63-8; CAS 64742-65-0; CAS 72623-85-9; CAS 72623-86-0; CAS 72623-87-1

Note: State, local or other agencies or advisory groups may have established more stringent limits.
Consult an industrial hygienist or similar professional, or your local agencies, for further information.

1%=10,000 PPM.

All components are listed on the TSCA inventory.

3. HAZARDS IDENTIFICATION

Potential Health Effects:

Eye: Contact may cause mild eye irritation including stinging, watering, and redness.

Skin: Contact may cause mild skin irritation including redness, and a burning sensation. Prolonged or repeated contact can worsen irritation by causing drying and cracking of the skin leading to dermatitis (inflammation). No harmful effects from skin absorption are expected.

Inhalation (Breathing): No information available. Studies by other exposure routes suggest a low degree of toxicity by inhalation.

Ingestion (Swallowing): No harmful effects expected from ingestion.

Signs and Symptoms: Effects of overexposure may include irritation of the nose and throat, irritation of the digestive tract, nausea and diarrhea.

Cancer: Inadequate evidence available to evaluate the cancer hazard of this material. See Section 11 for carcinogenicity information of individual components, if any.

Target Organs: No data available for this material.

Developmental: No data available for this material.

Pre-Existing Medical Conditions: Conditions aggravated by exposure may include skin disorders.

4. FIRST AID MEASURES

Eye: If irritation or redness develops, move victim away from exposure and into fresh air. Flush eyes with clean water. If symptoms persist, seek medical attention.

Skin: Wipe material from skin and remove contaminated shoes and clothing. Cleanse affected area(s) thoroughly by washing with mild soap and water and, if necessary, a waterless skin cleanser. If irritation or redness develops and persists, seek medical attention.

Inhalation (Breathing): If respiratory symptoms develop, move victim away from source of exposure and into fresh air. If symptoms persist, seek medical attention. If victim is not breathing, clear airway and immediately begin artificial respiration. If breathing difficulties develop, oxygen should be administered by qualified personnel. Seek immediate medical attention.

Ingestion (Swallowing): First aid is not normally required; however, if swallowed and symptoms develop, seek medical attention.

Note To Physicians: High-pressure hydrocarbon injection injuries may produce substantial necrosis of underlying tissue despite an innocuous appearing external wound. Often these injuries require extensive emergency surgical debridement and all injuries should be evaluated by a specialist in order to assess the extent of injury.

5. FIRE FIGHTING MEASURES

Flammable Properties:

- Flash Point: >384°F/>196°C (COC)
- OSHA Flammability Class: Not applicable
- LEL/UEL%: No Data
- Autoignition Temperature: No Data

Unusual Fire & Explosion Hazards: This material may burn, but will not ignite readily. If container is not properly cooled, it can rupture in the heat of a fire.

Extinguishing Media: Dry chemical, carbon dioxide, foam, or water spray is recommended. Water or foam may cause frothing of materials heated above 212°F. Carbon dioxide can displace oxygen. Use caution when applying carbon dioxide in confined spaces.

Fire Fighting Instructions: For fires beyond the incipient stage, emergency responders in the immediate hazard area should wear bunker gear. When the potential chemical hazard is unknown, in enclosed or confined spaces, or when explicitly required by DOT, a self contained breathing apparatus should be worn. In addition, wear other appropriate protective equipment as conditions warrant (see Section 8).

Isolate immediate hazard area, keep unauthorized personnel out. Stop spill/release if it can be done with minimal risk. Move undamaged containers from immediate hazard area if it can be done with minimal risk.

Water spray may be useful in minimizing or dispersing vapors and to protect personnel. Cool equipment exposed to fire with water, if it can be done with minimal risk. Avoid spreading burning liquid with water used for cooling purposes.

6. ACCIDENTAL RELEASE MEASURES

This material may burn, but will not ignite readily. Keep all sources of ignition away from spill/release. Stay upwind and away from spill/release. Notify persons down wind of the spill/release, isolate immediate hazard area and keep unauthorized personnel out. Stop spill/release if it can be done with minimal risk. Wear appropriate protective equipment including respiratory protection as conditions warrant (see Section 8).

(MSDS: 722330)

Page 4 of 7

Prevent spilled material from entering sewers, storm drains, other unauthorized drainage systems, and natural waterways. Dike far ahead of spill for later recovery or disposal. Spilled material may be absorbed into an appropriate absorbent material.

Notify fire authorities and appropriate federal, state, and local agencies. Immediate cleanup of any spill is recommended. If spill of any amount is made into or upon navigable waters, the contiguous zone, or adjoining shorelines, notify the National Response Center (phone number 800-424-8802).

7. HANDLING AND STORAGE

Handling: Do not enter confined spaces such as tanks or pits without following proper entry procedures such as ASTM D-4276 and 29CFR 1910.146. The use of appropriate respiratory protection is advised when concentrations exceed any established exposure limits (see Sections 2 and 8).

Do not wear contaminated clothing or shoes. Use good personal hygiene practices.

High pressure injection of hydrocarbon fuels, hydraulic oils or greases under the skin may have serious consequences even though no symptoms or injury may be apparent. This can happen accidentally when using high pressure equipment such as high pressure grease guns, fuel injection apparatus or from pinhole leaks in tubing of high pressure hydraulic oil equipment.

"Empty" containers retain residue and may be dangerous. Do not pressurize, cut, weld, braze, solder, drill, grind, or expose such containers to heat, flame, sparks, or other sources of ignition. They may explode and cause injury or death. "Empty" drums should be completely drained, properly bunged, and promptly shipped to the supplier or a drum reconditioner. All containers should be disposed of in an environmentally safe manner and in accordance with governmental regulations.

Before working on or in tanks which contain or have contained this material, refer to OSHA regulations, ANSI Z49.1 and other references pertaining to cleaning, repairing, welding, or other contemplated operations.

Storage: Keep container(s) tightly closed. Use and store this material in cool, dry, well-ventilated areas away from heat and all sources of ignition. Store only in approved containers. Keep away from any incompatible material (see Section 10). Protect container(s) against physical damage.

8. EXPOSURE CONTROLS/PERSONAL PROTECTION

Engineering controls: If current ventilation practices are not adequate to maintain airborne concentrations below the established exposure limits (see Section 2), additional engineering controls may be required.

Personal Protective Equipment (PPE):

Respiratory: A NIOSH certified air purifying respirator with a Type 95 (R or P) particulate filter may be used under conditions where airborne concentrations are expected to exceed exposure limits (see Section 2).

Protection provided by air purifying respirators is limited (see manufacturer's respirator selection guide). Use a NIOSH approved self-contained breathing apparatus (SCBA) or equivalent operated in a pressure demand or other positive pressure mode if there is potential for an uncontrolled release, exposure levels are not known, or any other circumstances where air purifying respirators may not provide adequate protection. A respiratory protection program that meets OSHA's 29 CFR 1910.134 and ANSI Z88.2 requirements must be followed whenever workplace conditions warrant a respirator's use.

Skin: The use of gloves impervious to the specific material handled is advised to prevent skin contact and possible irritation (see manufacturers literature for information on permeability).

Eye/Face: Approved eye protection to safeguard against potential eye contact, irritation, or injury is recommended. Depending on conditions of use, a face shield may be necessary.

Other Protective Equipment: A source of clean water should be available in the work area for flushing eyes and skin. Impervious clothing should be worn as needed.

Suggestions for the use of specific protective materials are based on readily available published data. Users should check with specific manufacturers to confirm the performance of their products.

9. PHYSICAL AND CHEMICAL PROPERTIES

Note: Unless otherwise stated, values are determined at 20°C (68°F) and 760 mm Hg (1 atm).

Appearance: Clear and bright

Physical State: Liquid

Odor: Mild petroleum

pH: Not applicable

Vapor Pressure (mm Hg): <1

Vapor Density (air=1): >1

Boiling Point/Range: No Data

Freezing/Melting Point: <-27°F / <-33°C

Solubility in Water: Negligible

Specific Gravity: 0.855-0.871

Percent Volatile: Negligible

Evaporation Rate (nBuAc=1): Negligible

Viscosity: 22-68 cSt @ 40°C / 4.3-8.7 cSt @ 100°C

Bulk Density: 7.13-7.26 lb/gal

Flash Point: >384°F / >196°C (COC)

Flammable/Explosive Limits (%): No Data

10. STABILITY AND REACTIVITY

Stability: Stable under normal ambient and anticipated storage and handling conditions of temperature and pressure.

Conditions To Avoid: Extended exposure to high temperatures can cause decomposition.

Materials to Avoid (Incompatible Materials): Avoid contact with strong oxidizing agents.

Hazardous Decomposition Products: Combustion can yield carbon, nitrogen, sulfur, phosphorus, and zinc oxides.

Hazardous Polymerization: Will not occur.

11. TOXICOLOGICAL INFORMATION

Lubricant Base Oil (Petroleum) (CAS# Various)

Carcinogenicity: The petroleum base oils contained in this product have been highly refined by a variety of processes including solvent extraction, hydrotreating, and dewaxing to remove aromatics and improve performance characteristics. None of the oils used are listed as a carcinogen by NTP, IARC, or OSHA.

12. ECOLOGICAL INFORMATION

Not evaluated at this time

(MSDS: 722330)

Page 6 of 7

13. DISPOSAL CONSIDERATIONS

This material under most intended uses would become used oil due to contamination by physical or chemical impurities. RECYCLE ALL USED OIL. While being recycled, used oil is regulated by 40 CFR 279. Use resulting in chemical or physical change or contamination may also subject it to regulation as hazardous waste. Under federal regulations, used oil is a solid waste managed under 40 CFR 279. However, in California, used oil is managed as hazardous waste until tested to show it is not hazardous. Consult state and local regulations regarding the proper handling of used oil. In the case of used oil, the intent to discard it may cause the used oil to be regulated as hazardous waste.

Contents should be completely used and containers emptied prior to discard. Rinsate may be considered a RCRA hazardous waste and must be disposed of with care and in compliance with federal, state and local regulations. Large empty containers, such as drums, should be returned to the distributor or a drum reconditioner. To assure proper disposal of small empty containers, consult with state and local regulations and disposal authorities.

14. TRANSPORT INFORMATION

DOT Shipping Description: Not classified as hazardous

15. REGULATORY INFORMATION

EPA SARA 311/312 (Title III Hazard Categories):

Acute Health: No
 Chronic Health: No
 Fire Hazard: No
 Pressure Hazard: No
 Reactive Hazard: No

SARA 313 and 40 CFR 372:

This material contains the following chemicals subject to the reporting requirements of SARA 313 and 40 CFR 372:

Component	CAS Number	Weight %
Zinc Compound	Proprietary	<1

California Proposition 65:

Warning: This material contains the following chemicals which are known to the State of California to cause cancer, birth defects or other reproductive harm, and are subject to the requirements of California Proposition 65 (CA Health & Safety Code Section 25249.5):

--None Known--

Carcinogen Identification:

This material has not been identified as a carcinogen by NTP, IARC, or OSHA. See Section 11 for carcinogenicity information of individual components, if any.

EPA (CERCLA) Reportable Quantity:

--None--

Canada - Domestic Substances List: Listed

WHMIS Class:

Not regulated

This product has been classified in accordance with the hazard criteria of the Controlled Products Regulations (CPR) and the MSDS contains all the information required by the CPR.

16. OTHER INFORMATION

Issue Date: 02/06/03

(MSDS: 722330)

Page 7 of 7

Previous Issue Date: 01/01/02
Product Code: 4641032000, 4642046000, 4643068000
Revised Sections: New Format
Previous Product Code: 4641032000
MSDS Number: 722330
Status: Final

Disclaimer of Expressed and Implied Warranties:

The information presented in this Material Safety Data Sheet is based on data believed to be accurate as of the date this Material Safety Data Sheet was prepared. **HOWEVER, NO WARRANTY OF MERCHANTABILITY, FITNESS FOR ANY PARTICULAR PURPOSE, OR ANY OTHER WARRANTY IS EXPRESSED OR IS TO BE IMPLIED REGARDING THE ACCURACY OR COMPLETENESS OF THE INFORMATION PROVIDED ABOVE, THE RESULTS TO BE OBTAINED FROM THE USE OF THIS INFORMATION OR THE PRODUCT, THE SAFETY OF THIS PRODUCT, OR THE HAZARDS RELATED TO ITS USE.** No responsibility is assumed for any damage or injury resulting from abnormal use or from any failure to adhere to recommended practices. The information provided above, and the product, are furnished on the condition that the person receiving them shall make their own determination as to the suitability of the product for their particular purpose and on the condition that they assume the risk of their use. In addition, no authorization is given nor implied to practice any patented invention without a license.

 **CLIMAX**
Family of Brands

 **BORTECH**

 **CALDER**
TESTERS

H&S TOOL