

CE

SPEED FACER

ODF50 SPEED FACER
OPERATING MANUAL
ORIGINAL INSTRUCTIONS



H&S TOOL
A CLIMAX COMPANY

P/N 87522
February 2018
Revision 2

CLIMAX | BORTECH CALDER H&S TOOL

©2018 CLIMAX or its subsidiaries.
All rights reserved.

Except as expressly provided herein, no part of this manual may be reproduced, copied, transmitted, disseminated, downloaded, or stored in any storage medium, without the express prior written consent of CLIMAX. CLIMAX hereby grants permission to download a single copy of this manual and of any revision hereto onto an electronic storage medium to be viewed and to print one copy of this manual or any revision hereto, provided that such electronic or printed copy of this manual or revision must contain the complete text of this copyright notice and provided further that any unauthorized commercial distribution of this manual or any revision hereto is prohibited.

At CLIMAX, we value your opinion.

For comments or questions about this manual or other CLIMAX documentation, please e-mail documentation@cpmt.com.

For comments or questions about CLIMAX products or services, please call CLIMAX or e-mail info@cpmt.com. For quick and accurate service, please provide your representative with the following:

- Your name
- Shipping address
- Telephone number
- Machine model
- Serial number (if applicable)
- Date of purchase

CLIMAX World Headquarters

2712 East 2nd Street
Newberg, Oregon 97132 USA

Telephone (worldwide): +1-503-538-2815
Toll-free (North America): 1-800-333-8311
Fax: 503-538-7600

CLIMAX | H&S Tool (UK Headquarters)

Unit 7 Castlehill Industrial Estate
Bredbury Industrial Park
Horsfield Way
Stockport SK6 2SU, UK

Telephone: +44 (0) 161-406-1720

CLIMAX | H&S Tool (Asia Pacific Headquarters)

316 Tanglin Road #02-01
Singapore 247978

Telephone: +65-9647-2289
Fax: +65-6801-0699

H&S Tool World Headquarters

715 Weber Dr.
Wadsworth, OH 44281 USA

Telephone: +1-330-336-4550
Fax: 1-330-336-9159
hstool.com

CLIMAX | H&S Tool (European Headquarters)

Am Langen Graben 8
52353 Düren, Germany

Telephone: +49 (0) 242-191-7712
E-mail: info@cpmt.de

CLIMAX | H&S Tool (Middle East Headquarters)

Warehouse #5, Plot: 369 272
Um Sequim Road
Al Quoz 4
PO Box 414 084
Dubai, UAE

Telephone: +971-04-321-0328

CLIMAX GLOBAL LOCATIONS

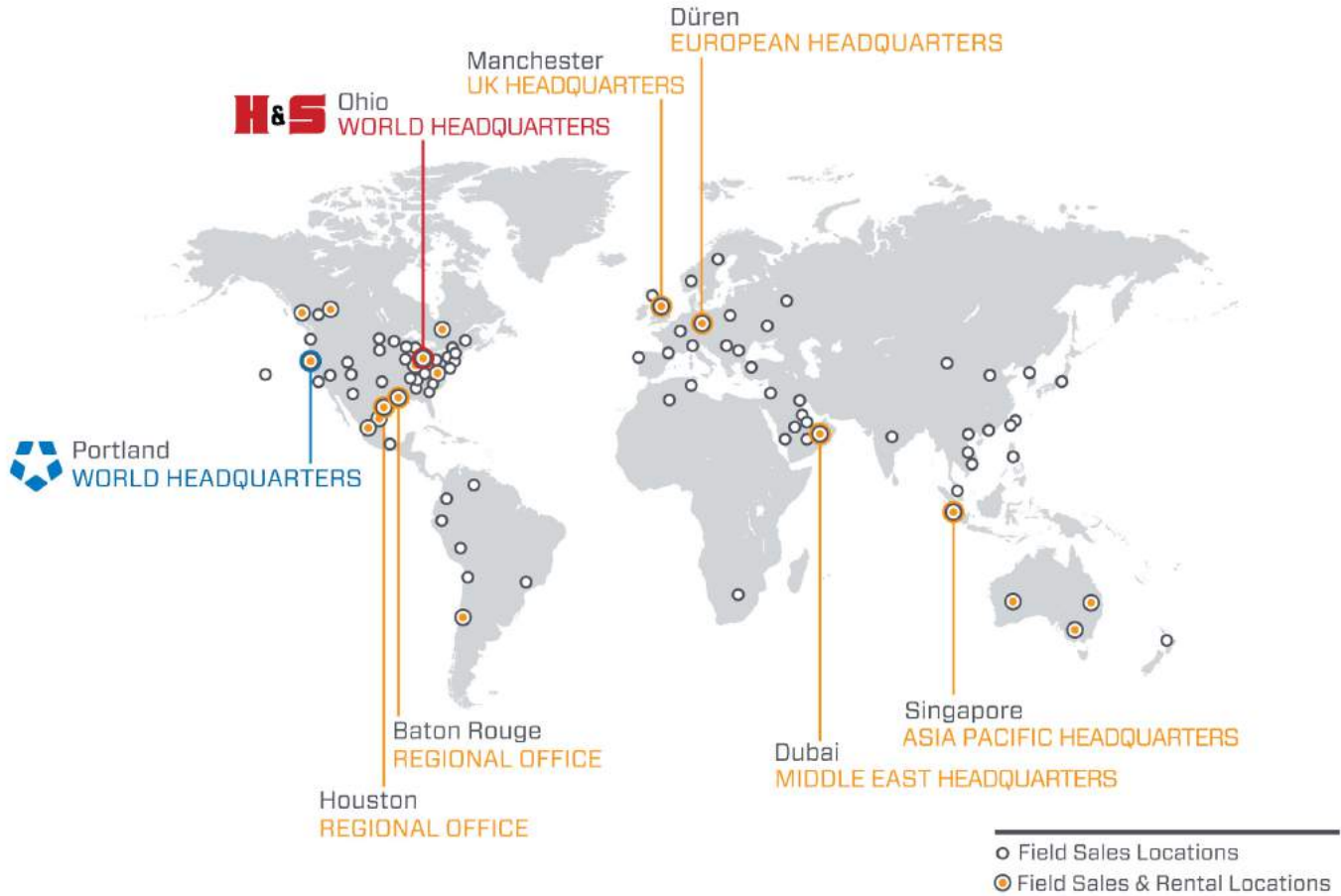

CE DOCUMENTATION

**Name of manufacturer or supplier**

H&S Tool

Full postal address including country of origin

715 Weber Drive
Wadsworth, OH 44281
USA

Description of product

ODF50 Speedfacer Flange Facer

Name, type or model, batch or serial number

Model ODF50

Serial Number Range OD50071601 to
OD50122001

Pneumatic Powered

Standards used, including number, title, issue date and other relative documents

EN 953, EN 3744, EN 4413, EN 4414, EN 11201, EN 12100, EN 13128, EN 13732, EN 13849, EN 13857

Name of Responsible Person within the EU Tom Cunningham**Full postal address if different from manufacturers**

Climax GmbH
Am Langen Graben 8
52353 Duren, Germany

Declaration

I declare that as the Manufacturer, the above information in relation to the supply / manufacture of this product, is in conformity with the stated standards and other related documents following the provisions of the above Directives and their amendments.

Signature of Manufacturer: Position Held: Date: 

LIMITED WARRANTY

Climax Portable Machine Tools, Inc. (hereafter referred to as “Climax”) warrants that all new machines are free from defects in materials and workmanship. This warranty is available to the original purchaser for a period of one year after delivery. If the original purchaser finds any defect in materials or workmanship within the warranty period, the original purchaser should contact its factory representative and return the entire machine, shipping prepaid, to the factory. Climax will, at its option, either repair or replace the defective machine at no charge and will return the machine with shipping prepaid.

Climax warrants that all parts are free from defects in materials and workmanship, and that all labor has been performed properly. This warranty is available to the customer purchasing parts or labor for a period of 90 days after delivery of the part or repaired machine or 180 days on used machines and components. If the customer purchasing parts or labor finds any defect in materials or workmanship within the warranty period, the purchaser should contact its factory representative and return the part or repaired machine, shipping prepaid, to the factory. Climax will, at its option, either repair or replace the defective part and/ or correct any defect in the labor performed, both at no charge, and return the part or repaired machine shipping prepaid.

These warranties do not apply to the following:

- Damage after the date of shipment not caused by defects in materials or workmanship
- Damage caused by improper or inadequate machine maintenance
- Damage caused by unauthorized machine modification or repair
- Damage caused by machine abuse
- Damage caused by using the machine beyond its rated capacity

All other warranties, express or implied, including without limitation the warranties of merchantability and fitness for a particular purpose are disclaimed and excluded.

Terms of sale

Be sure to review the terms of sale which appear on the reverse side of your invoice. These terms control and limit your rights with respect to the goods purchased from Climax.

About this manual

Climax provides the contents of this manual in good faith as a guideline to the operator. Climax cannot guarantee that the information contained in this manual is correct for applications other than the application described in this manual. Product specifications are subject to change without notice.

TABLE OF CONTENTS

CHAPTER/SECTION	PAGE
1 INTRODUCTION	1
1.1 HOW TO USE THIS MANUAL	1
1.2 SAFETY ALERTS	1
1.3 GENERAL SAFETY PRECAUTIONS	2
1.4 MACHINE-SPECIFIC SAFETY PRECAUTIONS	2
1.5 RISK ASSESSMENT AND HAZARD MITIGATION	4
1.6 RISK ASSESSMENT CHECKLIST	5
1.7 LABELS	6
1.7.1 Label identification	6
1.7.2 Label location	7
2 OVERVIEW	9
2.1 FEATURES AND COMPONENTS	9
2.2 CONTROLS	10
2.3 DIMENSIONS	10
2.4 SPECIFICATIONS	12
2.5 ITEMS REQUIRED BUT NOT SUPPLIED	12
3 SETUP	13
3.1 RECEIPT AND INSPECTION	13
3.2 LIFTING AND RIGGING	13
3.3 INSTALLATION HAZARDS	14
3.3.1 Horizontal mounting	15
3.3.2 Vertical mounting	15
3.3.3 Overhead mounting	16
3.4 MACHINE ASSEMBLY	16
3.4.1 Chuck foot spacers	17
3.4.2 Centering and leveling	17
3.4.3 Installing the cutting bit or insert holder	18
3.4.4 Installing the offset tool holder	19
3.4.5 Rotating the tool head	19
3.4.6 Adjusting the feed	19
3.4.7 Installing the drive motor	20
3.4.8 Connecting the Air Caddy	20
4 OPERATION	21
4.1 PRE-OPERATION CHECKS	21
4.2 OPERATION MODES	21
4.2.1 Configuring for flange facing	21

TABLE OF CONTENTS (CONTINUED)

CHAPTER/SECTION	PAGE
4.2.2 Configuring for a counterbore	22
4.2.3 Configuring for the backfacing attachment	22
4.3 OPERATION	23
4.3.1 Starting the machine	23
4.3.2 Stopping the machine	24
4.3.3 Adjusting the machine settings	24
5 MAINTENANCE	25
5.1 MAINTENANCE CHECKLIST	25
5.2 APPROVED LUBRICANTS	25
5.3 MAINTENANCE TASKS	26
5.3.1 Checking the Air Caddy oil reservoir and particulate filter trap	26
5.3.2 Checking the Air Caddy drop-out circuit	26
5.3.3 Testing the emergency stop	27
5.3.4 Dovetail ways	27
5.3.5 Lubricating the roller bearing.	27
5.3.6 Belt adjustment and replacement	27
5.3.7 Guard installation and removal	28
5.3.8 Roller adjustment	28
5.3.9 Trip cable replacement	29
5.4 TROUBLESHOOTING	31
5.4.1 The machine isn't turning	31
5.4.2 The machine isn't feeding	31
5.4.3 The machine is performing poorly.	31
5.4.4 The machine isn't cutting flat.	31
6 STORAGE AND SHIPPING	33
6.1 STORAGE	33
6.1.1 Short-term storage	33
6.1.2 Long-term storage.	33
6.2 SHIPPING.	34
6.3 DECOMMISSIONING	34
APPENDIX A ASSEMBLY DRAWINGS	35
APPENDIX B SDS	55

LIST OF FIGURES

FIGURE	PAGE
1-1 ODF50 label location	8
1-2 60220 label location (under machine)	8
2-1 Extension feet installed	9
2-2 Air caddy controls	10
2-3 ODF50 Speed Facer dimensions (P/N 86980)	11
3-1 Lifting points (ODF40 machine shown)	14
3-2 Vertical hazard.	14
3-3 Mounting arrangements.	15
3-4 Alternate mounting holes	15
3-5 Bolt and hole locations	16
3-6 Leveling foot components	16
3-7 Chuck foot spacers	17
3-8 Dial indicator mounted for leveling	17
3-9 Location of swivel clamping screw	18
3-10 .50" tool adapter installed (P/N 89175)	18
3-11 Offset tool holder (P/N 89203).	19
3-12 Feed tripper location	19
3-13 Feed adjustments	20
3-14 Installed air motor drive	20
4-1 Gib lock screws	22
4-2 Backfacing components	22
4-3 Repositioned backfacing components.	23
4-4 Air caddy controls	23
4-5 Feed adjustment screw and feed direction knob	24
5-1 Grease fitting	27
5-2 Box wrench over screw	28
5-3 Punches used for guard installation	28
5-4 Initial roller bearing locations	29
5-5 Adjusting and tightening of the bushings and cap screws.	29
5-6 Checking for play between the track ring and the stationary ring	29
5-7 Location of M4 screw (left); cable end under M4 screw and jam nut with adjusting bolt (right).	30
5-8 Barrel end of cable removal (left); Cable and housing cutters (right)	30
5-9 Barrel end of cable with spring, ferrule installed on cable housing (left); cable installed in actuator housing (right)	30
5-10 90° elbow, adjusting nut and jam nut (left); cable end shown at trimming location (right).	30
5-11 Solder-treated cable end (left); cable end secured under the M4 screw (right)	31
6-1 ODF50 crate	34
A-1 ODF50 Speed Facer assembly (P/N 86980)	36
A-2 ODF50 Speed Facer labels assembly (P/N 86980)	37
A-3 ODF50 Speed Facer parts list (P/N 86980)	38
A-4 Slide tool holder assembly (P/N 89210)	39
A-5 Slide tool holder parts list (P/N 89210)	40
A-6 Pneumatic conditioning unit assembly (P/N 83430)	41
A-7 Pneumatic conditioning unit assembly (P/N 83430)	42

LIST OF FIGURES (CONTINUED)

FIGURE	PAGE
A-8 Jacking foot leveling assembly (P/N 86880)	43
A-9 Radial axis assembly (P/N 86890)	44
A-10 Radial axis assembly parts list (P/N 86890)	45
A-11 Pull cable feedbox assembly (P/N 86900)	46
A-12 Feed actuator in the pull cable feedbox assembly (P/N 86900)	47
A-13 Feed tripper assembly (P/N 86910)	48
A-14 Non-leveling jacking foot assembly (P/N 86970)	49
A-15 Drive motor assembly (P/N 86989)	50
A-16 Extension foot assembly (P/N 87164)	51
A-17 Backfacing attachment assembly (P/N 87310)	52
A-18 Cable protection components	53
A-19 Tool kit (P/N 78530)	54

LIST OF TABLES

TABLE	PAGE
1-1 Sound levels	2
1-2 Risk assessment checklist before set-up	5
1-3 Risk assessment checklist after set-up	5
1-4 ODF50 Speed Facer labels	6
2-1 Sub-component mass	12
3-1 ODF50 mounting feet	16
5-1 Maintenance intervals and tasks	25
5-2 Approved lubricants	26

This page intentionally left blank

1 INTRODUCTION

IN THIS CHAPTER:

1.1 HOW TO USE THIS MANUAL - - - - - 1

1.2 SAFETY ALERTS - - - - - 1

1.3 GENERAL SAFETY PRECAUTIONS - - - - - 2

1.4 MACHINE-SPECIFIC SAFETY PRECAUTIONS - - - - - 2

1.5 RISK ASSESSMENT AND HAZARD MITIGATION - - - - - 4

1.6 RISK ASSESSMENT CHECKLIST - - - - - 5

1.7 LABELS - - - - - 6

 1.7.1 LABEL IDENTIFICATION - - - - - 6

 1.7.2 LABEL LOCATION - - - - - 7

1.1 HOW TO USE THIS MANUAL

This manual describes information necessary for the setup, operation, maintenance, storage, shipping, and decommissioning of the ODF50 Speed Facer.

The first page of each chapter includes a summary of the chapter contents to help you locate specific information. The appendices contain supplemental product information to aid in setup, operation, and maintenance tasks.

Read this entire manual to familiarize yourself with the ODF50 Speed Facer before attempting to set it up or operate it.

1.2 SAFETY ALERTS

Pay careful attention to the safety alerts printed throughout this manual. Safety alerts will call your attention to specific hazardous situations that may be encountered when operating this machine.

Examples of safety alerts used in this manual are defined here¹:

⚠ DANGER

indicates a hazardous situation which, if not avoided, **WILL** result in death or severe injury.

⚠ WARNING

indicates a hazardous situation which, if not avoided, **COULD** result in death or severe injury.

⚠ CAUTION

indicates a hazardous situation which, if not avoided, could result in minor or moderate injury.

NOTICE

indicates a hazardous situation which, if not avoided, could result in property damage, equipment failure, or undesired work results.

1. For more information on safety alerts, refer to *ANSI/NEMA Z535.6-2011, Product safety Information in Product Manuals, Instructions, and Other Collateral Materials*.

1.3 GENERAL SAFETY PRECAUTIONS

H&S leads the way in promoting the safe use of portable machine tools. Safety is a joint effort. You, the end user, must do your part by being aware of your work environment and closely following the operating procedures and safety precautions contained in this manual, as well as your employer's safety guidelines.

Observe the following safety precautions when operating or working around the machine.

Training - Before operating this or any machine tool, you should receive instruction from a qualified trainer. Contact H&S for machine-specific training information.

Risk assessment - Working with and around this machine poses risks to your safety. You, the end user, are responsible for conducting a risk assessment of each job site before setting up and operating this machine.

Intended use - Use this machine in accordance with the instructions and precautions in this manual. Do not use this machine for any purpose other than its intended use as described in this manual.

Personal protective equipment - Always wear appropriate personal protective gear when operating this or any other machine tool. Flame-resistant clothing with long sleeves and legs is recommended when operating the machine. Hot chips from the workpiece may burn or cut bare skin.

Work area - Keep the work area around the machine clear of clutter. Restrain cords and hoses connected to the machine. Keep other cords and hoses away from the work area.

Lifting - Many H&S machine components are very heavy. Whenever possible, lift the machine or its components using proper hoisting equipment and rigging. Always use designated lifting points on the machine. Follow lifting instructions in the setup procedures of this manual.

Lock-out/tag-out - Lock-out and tag-out the machine before performing maintenance.

Moving parts - H&S machines have numerous exposed moving parts and interfaces that can cause severe impact, pinching, cutting, and other injuries. Except for stationary operating controls, avoid contact with moving parts by hands or tools during machine operation. Remove gloves and secure hair, clothing, jewelry, and pocket items to prevent them from becoming entangled in moving parts.

Sharp edges - Cutting tools and workpieces have sharp edges that can easily cut skin. Wear protective gloves and exercise caution when handling a cutting tool or workpiece.

Hot surfaces - During operation, motors, pumps, HPU's, and cutting tools can generate enough heat to cause severe burns. Pay attention to hot surface labels, and avoid contact with bare skin until the machine has cooled.

1.4 MACHINE-SPECIFIC SAFETY PRECAUTIONS

Eye hazard - This machine produces metal chips during operation. Always wear eye protection when operating the machine.

Hazardous environments - Do not operate the machine in environments where potentially explosive materials, toxic chemicals, or radiation may be present.

Sound level - This machine produces potentially harmful sound levels. Hearing protection is required when operating this machine or working around it. During testing, the machine pro-

duced the sound levels¹ listed in Table 1-1.

TABLE 1-1. SOUND LEVELS

	Motor
Sound power	102.3 dBA
Operator sound pressure	87.6 dBA
Bystander sound pressure	85 dBA

1. Machine sound testing was conducted in accordance with European Harmonized Standards EN ISO 3744:2010 and EN 11201:2010.

Machine mounting - Do not operate the machine unless mounted to a workpiece in accordance with this manual. If mounting the machine in an overhead or vertical position, do not remove hoist rigging until the machine is mounted to the workpiece in accordance with this manual.

In any mounting position, verify that the machine is tethered and mounted so that if the machine slips or rotates, no injury or damage will occur.

1.5 RISK ASSESSMENT AND HAZARD MITIGATION

Machine Tools are specifically designed to perform precise material-removal operations.

Stationary Machine Tools include lathes and milling machines and are typically found in a machine shop. They are mounted in a fixed location during operation and are considered to be a complete, self-contained machine. Stationary Machine Tools achieve the rigidity needed to accomplish material-removal operations from the structure that is an integral part of the machine tool.

Portable Machine Tools are designed for on-site machining applications. They typically attach directly to the workpiece itself, or to an adjacent structure, and achieve their rigidity from the structure to which it is attached. The design intent is that the Portable Machine Tool and the structure to which it is attached become one complete machine during the material-removal process.

To achieve the intended results and to promote safety, the operator must understand and follow the design intent, set-up, and operation practices that are unique to Portable Machine Tools.

The operator must perform an overall review and on-site risk assessment of the intended application. Due to the unique nature of portable machining applications, identifying one or more hazards that must be addressed is typical.

When performing the on-site risk assessment, it is important to consider the Portable Machine Tool and the workpiece as a whole.

1.6 RISK ASSESSMENT CHECKLIST

The following checklist is not intended to be an all inclusive list of things to watch out for when setting up and operating this Portable Machine Tool.

However, these checklists are typical of the types of risks the assembler and operator should consider. Use these checklists as part of your risk assessment:

TABLE 1-2. RISK ASSESSMENT CHECKLIST BEFORE SET-UP

Before set-up	
<input type="checkbox"/>	I took note of all the warning labels on the machine.
<input type="checkbox"/>	I removed or mitigated all identified risks (such as tripping, cutting, crushing, entanglement, shearing, or falling objects).
<input type="checkbox"/>	I considered the need for personnel safety guarding and installed any necessary guards.
<input type="checkbox"/>	I read the machine assembly instructions (Section 3.3) and took inventory of all the items required but not supplied (Section 2.5).
<input type="checkbox"/>	I created a lift plan, including identifying the proper rigging, for each of the setup lifts required during the setup of the support structure and machine.
<input type="checkbox"/>	I located the fall paths involved in lifting and rigging operations. I have taken precautions to keep workers away from the identified fall path.
<input type="checkbox"/>	I considered how this machine operates and identified the best placement for the controls, cabling, and the operator.
<input type="checkbox"/>	I evaluated and mitigated any other potential risks specific to my work area.

TABLE 1-3. RISK ASSESSMENT CHECKLIST AFTER SET-UP

After set-up	
<input type="checkbox"/>	I checked that the machine is safely installed (according to Section 3) and the potential fall path is clear. If the machine is installed at an elevated position, I checked that the machine is safeguarded against falling.
<input type="checkbox"/>	I identified all possible pinch points, such as those caused by rotating parts, and informed the affected personnel.
<input type="checkbox"/>	I planned for containment of any chips or swarf produced by the machine.
<input type="checkbox"/>	I followed the required Maintenance Intervals (Section 5.1) with the recommended lubricants (Section 5.2).
<input type="checkbox"/>	I checked that all affected personnel have the recommended personal protective equipment, as well as any site-required or regulatory equipment.
<input type="checkbox"/>	I checked that all affected personnel understand and are clear of the danger zone.
<input type="checkbox"/>	I evaluated and mitigated any other potential risks specific to my work area.

1.7 LABELS

1.7.1 Label identification

The following warning labels should be on your machine. If any are defaced or missing, contact H&S immediately for replacements.

TABLE 1-4. ODF50 SPEED FACER LABELS













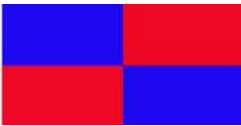

	<p>P/N 29152 Mass plate</p>		<p>P/N 46902 Warning label: hot surface</p>
	<p>P/N 59039 Warning label: lift point</p>		<p>P/N 59042 Warning label: danger of hand caught in moving parts</p>
<p>HOSE ARR</p>  <p>BASE</p>	<p>PN 60219 Hose connect schematic for red-red/blue-blue</p>	<p>HOSE ARR</p>  <p>BASE</p>	<p>PN 60220 Hose connect schematic for blue-red/red-blue</p>
	<p>PN 79324 Warning label: danger of hand entanglement in rotating gears</p>		<p>PN 79385 Warning label: only lift the subassembly; check the operating manual</p>

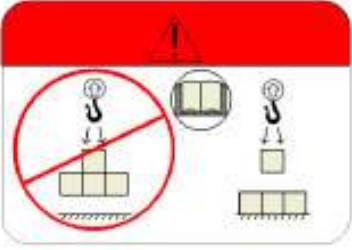
TABLE 1-4. ODF50 SPEED FACER LABELS

		<p>PN 84856 Warning label: tether machine before use</p>	
		<p>PN 87260 H&S ODF50 Speed Facer label</p>	
	<p>PN 87265 Black arrow on a yellow field</p>		<p>PN 87269 H&S serial plate</p>
	<p>PN 87271 Warning label: use eye and ear protection, and read the operating manual</p>		<p>PN 87272 Made in the USA label</p>
		<p>PN 87428 H&S ODF50 label</p>	

1.7.2 Label location

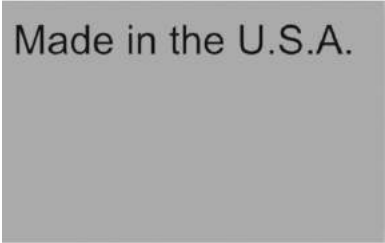
The following figures display the location of the labels on each of the components of the ODF50 Speed Facer.

For further identification of location placement, refer to the exploded views in Appendix A.



FIGURE 1-1. ODF50 LABEL LOCATION

Label P/N: 29152, 46902, 59039, 59042, 60219, 79324, 79385, 84856, 8726087265, 87269, 87271, 87272, 87428

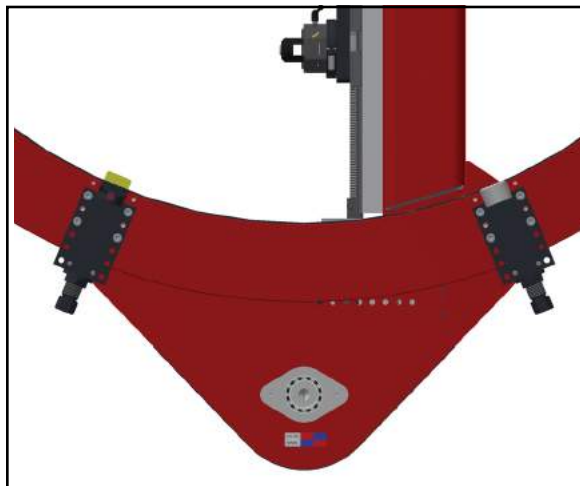

FIGURE 1-2. 60220 LABEL LOCATION (UNDER MACHINE)

Label P/N: 60220

2 OVERVIEW

IN THIS CHAPTER:

2.1 FEATURES AND COMPONENTS - - - - -	9
2.2 CONTROLS - - - - -	11
2.3 DIMENSIONS - - - - -	11
2.4 SPECIFICATIONS - - - - -	13
2.5 ITEMS REQUIRED BUT NOT SUPPLIED - - - - -	13

2.1 FEATURES AND COMPONENTS

The ODF50 Speed Facer is a portable, air powered, belt-driven, outer-diameter (OD)-mounted single-point flange facing machine for use on workpieces with an OD of 39.1-50.5" (993-1.283 mm), or 29.1-40.0" (739-1016 mm) with the optional extended mounting feet (shown in Figure 2-1).



FIGURE 2-1. EXTENSION FEET INSTALLED

Principle components include the following:

Pneumatic motor—The pneumatic motor is 1.35 hp, reversible, and can be installed from either the top or bottom of the machine depending on obstructions or operating mode.

Bridge radial axis—The radial axis incorporates lin-

ear ways and a ball screw for 13.9" (353 mm) of travel. It can be repositioned on the bridge to cut from the maximum OD to the zero center.

Tool holder assembly—The angle of the tool head is also adjustable 360 degrees for feeding axially at an angle. The tool post can be rotated independently to maintain tool geometry. The radial and axial position can be manually adjusted using a 3/8" ratchet driver.

Automatic feed unit—The automatic feed unit eliminates the need to manually manipulate the feed handles during operation. The ODF50 Speed Facer includes four feed trippers to actuate the adjustable feed unit. The feed can be adjusted from .001-.032" (.03-.8 mm) per revolution and can be used on either axis.

Jacking foot assembly—The jacking foot assemblies are designed for OD mounting only. The leveling jacking feet have adjustable jaws and work with the setup fingers to level the machine. Refer to Section 3.3 on page 14 for more mounting dimensional constraints.

Backfacing attachment—The optional backfacing attachment allows machining access when there are bridge obstructions. It can also be used to machine the backside of pipe flanges.

2.2 CONTROLS

The ODF50 Speed Facer controls are located on the pneumatic conditioning unit (Air Caddy), shown in Figure 2-2.

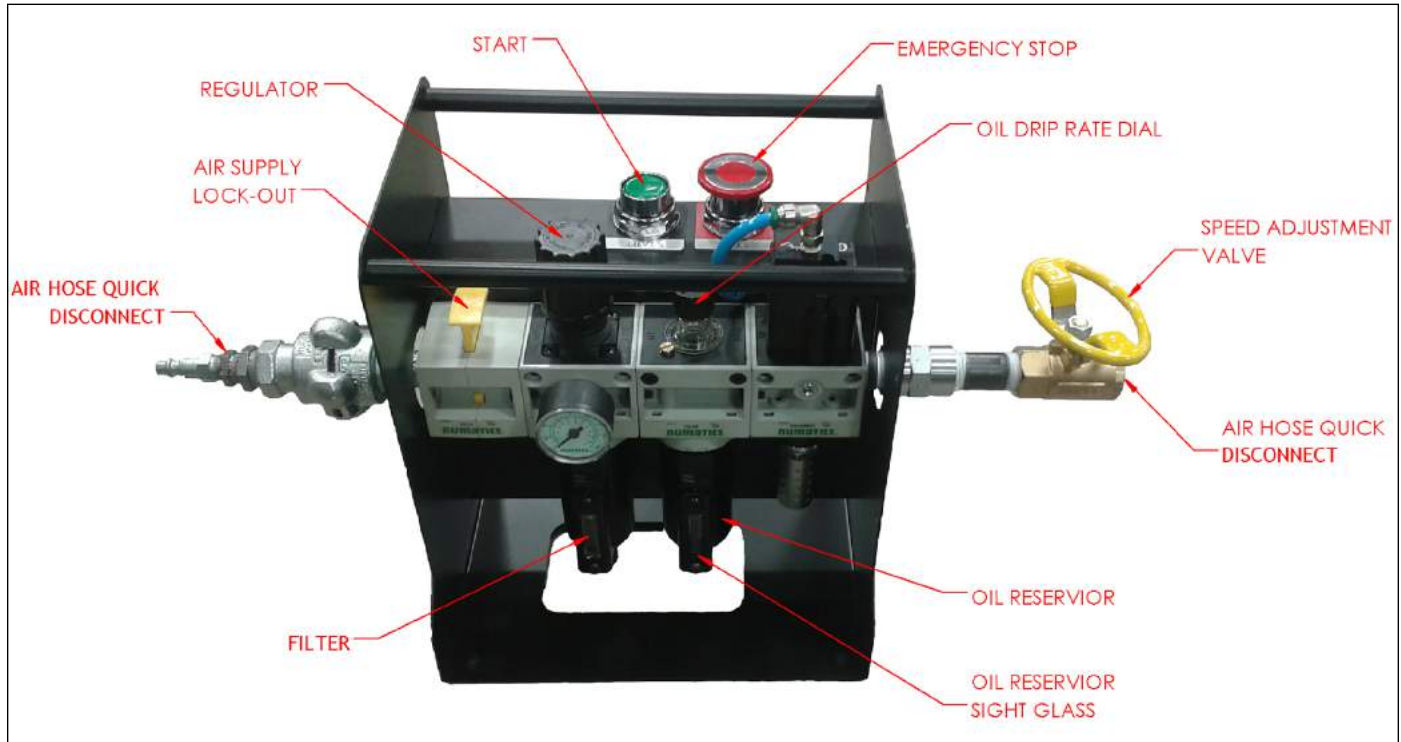

FIGURE 2-2. AIR CADDY CONTROLS

WARNING

Always stop the machine and lock-out/tag-out the Air Caddy before making adjustments to controls or machine components. Failure to follow this safety precaution may result in severe injury.

Emergency shutdown

To stop machine operation immediately, press the EMERGENCY STOP button on the Air Caddy.

Before restarting the ODF50 Speed Facer, do the following:

1. Close the speed adjustment valve.
2. Pull the EMERGENCY STOP button up.
3. Press the START button (repeat step 1 if necessary).

2.3 DIMENSIONS

Figure 2-3 shows the machine and operating dimensions.

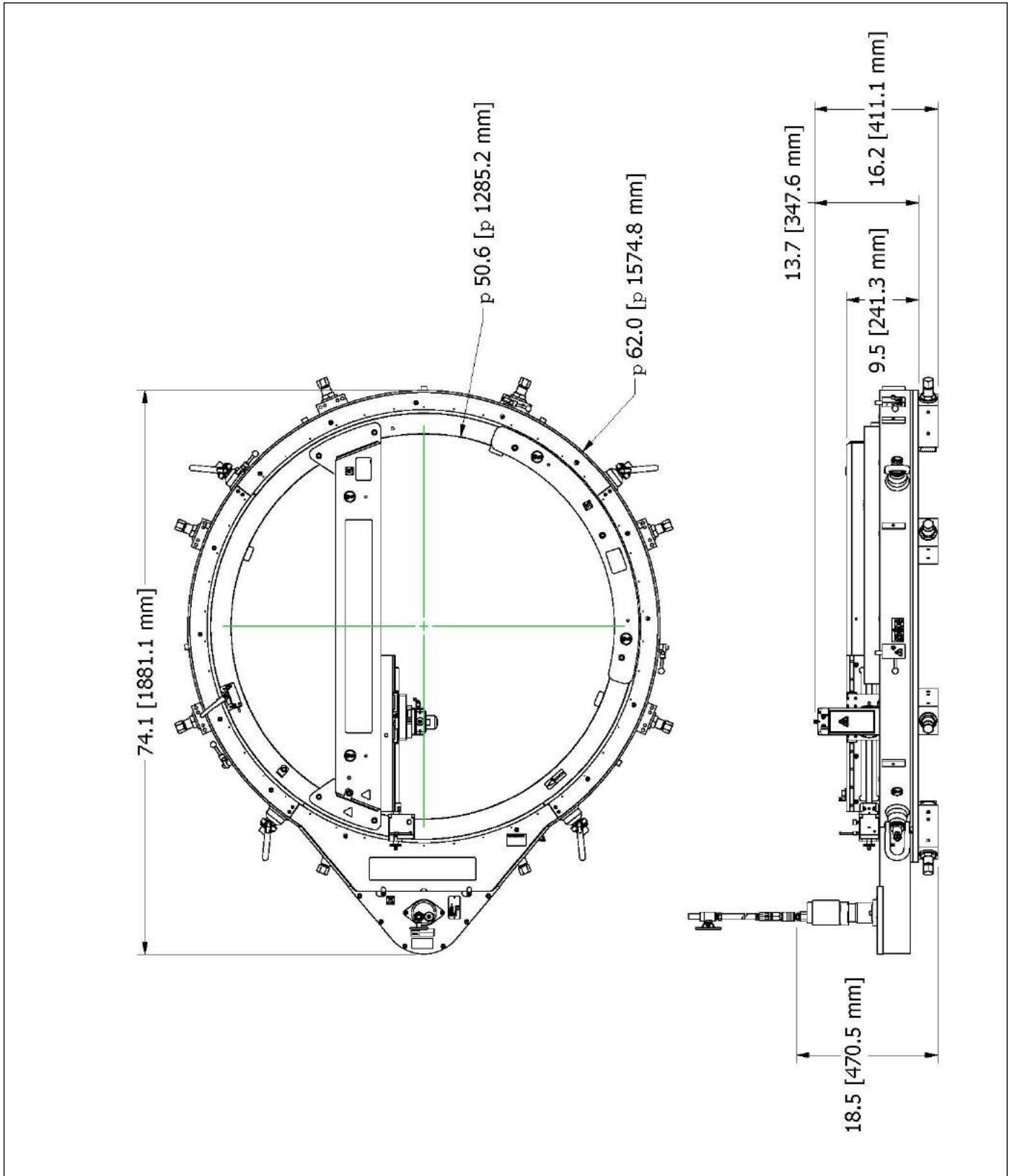

FIGURE 2-3. ODF50 SPEED FACER DIMENSIONS (P/N 86980)

2.4 SPECIFICATIONS

TABLE 2-1. SUB-COMPONENT MASS

P/N	Component	Mass in lbs (kg)
87164	Extension chuck foot kit assembly (eight total)	22.5 (10.2) each
87030	Backfacing attachment assembly	62 (28)
86987	ODF50 bridge weldment	155 (70)
86986	ODF50 counterweight	73 (33)
86980	ODF50 Speed Facer	1,688 (766)

2.5 ITEMS REQUIRED BUT NOT SUPPLIED

The following items are required but not supplied in your H&S product kit:

- Torque wrench
- Dial indicator
- Wood blocks
- Tape measure

3 SETUP

IN THIS CHAPTER:

3.1 RECEIPT AND INSPECTION	13
3.2 LIFTING AND RIGGING	13
3.3 INSTALLATION HAZARDS	14
3.3.1 HORIZONTAL MOUNTING	15
3.3.2 VERTICAL MOUNTING	15
3.3.3 OVERHEAD MOUNTING	16
3.4 MACHINE ASSEMBLY	16
3.4.1 CHUCK FOOT SPACERS	17
3.4.2 CENTERING AND LEVELING	17
3.4.3 INSTALLING THE CUTTING BIT OR INSERT HOLDER	18
3.4.4 INSTALLING THE OFFSET TOOL HOLDER	19
3.4.5 ROTATING THE TOOL HEAD	19
3.4.6 ADJUSTING THE FEED	19
3.4.7 INSTALLING THE DRIVE MOTOR	20
3.4.8 CONNECTING THE AIR CADDY	20

This section describes the setup and assembly procedures for the ODF50 Speed Facer.

3.1 RECEIPT AND INSPECTION

Your H&S product was inspected and tested prior to shipment, and packaged for normal shipment conditions. H&S does not guarantee the condition of your machine upon delivery.

When you receive your H&S product, perform the following receipt checks:

1. Inspect the shipping containers for damage.
2. Check the contents of the shipping containers against the included invoice to make sure that all components have been shipped.
3. Inspect all components for damage.

Contact H&S immediately to report damaged or missing components.

NOTICE

Keep the shipping container and all packing materials for future storage and shipping of the machine.

The machine ships from H&S with a heavy coating of LPS 3. The recommended cleaner is LPS PreSolve Orange Degreaser. All parts must be cleaned before use.

3.2 LIFTING AND RIGGING

Before unpacking the shipping containers, complete the risk assessment checklist in Table 1-2 on page 5.

Before lifting, make sure all parts are securely attached to the machine.

! DANGER

The ODF50 Speed Facer can weigh up to 1,688 lbs (766 kg) when fully assembled. To prevent serious injury to yourself and others, always follow the operating procedures outlined in this manual, your own company rules, and local regulations for heavy lifting. Serious injury or fatalities can result from improper lifting methods.

Do the following for correct lifting:

1. Attach four 3/4" swivel hoist rings to the machine, if not already attached.

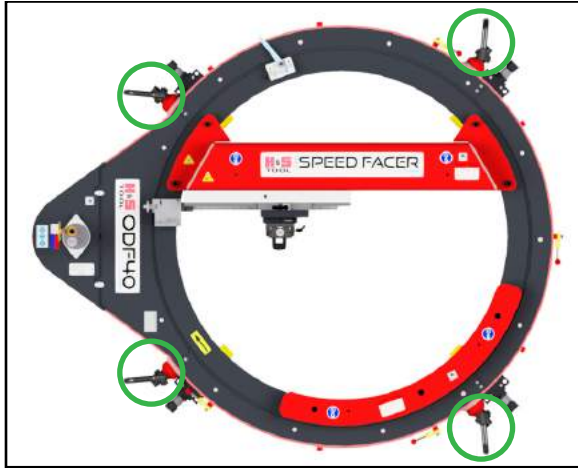

FIGURE 3-1. LIFTING POINTS (ODF40 MACHINE SHOWN)

! CAUTION

Falling or uncontrolled swinging of machinery can cause serious injury or be fatal to the operator and bystanders. Only lift the machine by the 3/4" hoist rings identified in Figure 3-1. Do not lift the ODF50 Speed Facer using smaller lifting points located on the bridge or counterweight.

2. Attach customer-supplied rigging to the hoist rings on the table.

! CAUTION

Make sure the rigging is correctly attached before lifting the machine. Lift the machine slowly, making sure that no components will be crushed or bent if the machine is lifted in the vertical orientation. If the rigging causes the machine to swing or become unstable, lower it and adjust the rigging.

3. Rig the machine out of the shipping crate.

3.3 INSTALLATION HAZARDS

The installation stage can be dangerous, as it relies on the operator and other personnel following the recommended safety precautions. Consider the following warnings carefully before undertaking the assembly process.

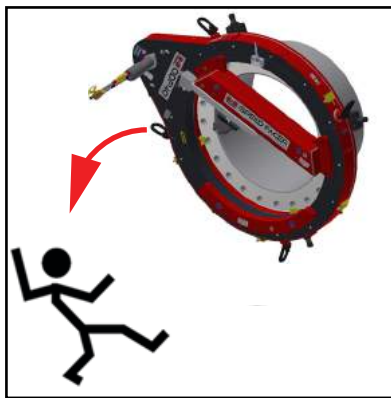

FIGURE 3-2. VERTICAL HAZARD

! WARNING

If not properly secured, this machine can fall and cause fatal injuries to personnel. Pay special attention to vertical flange and overhead mounting installations.

Secure all components to the machine before lifting. Use supplemental rigging during setup.

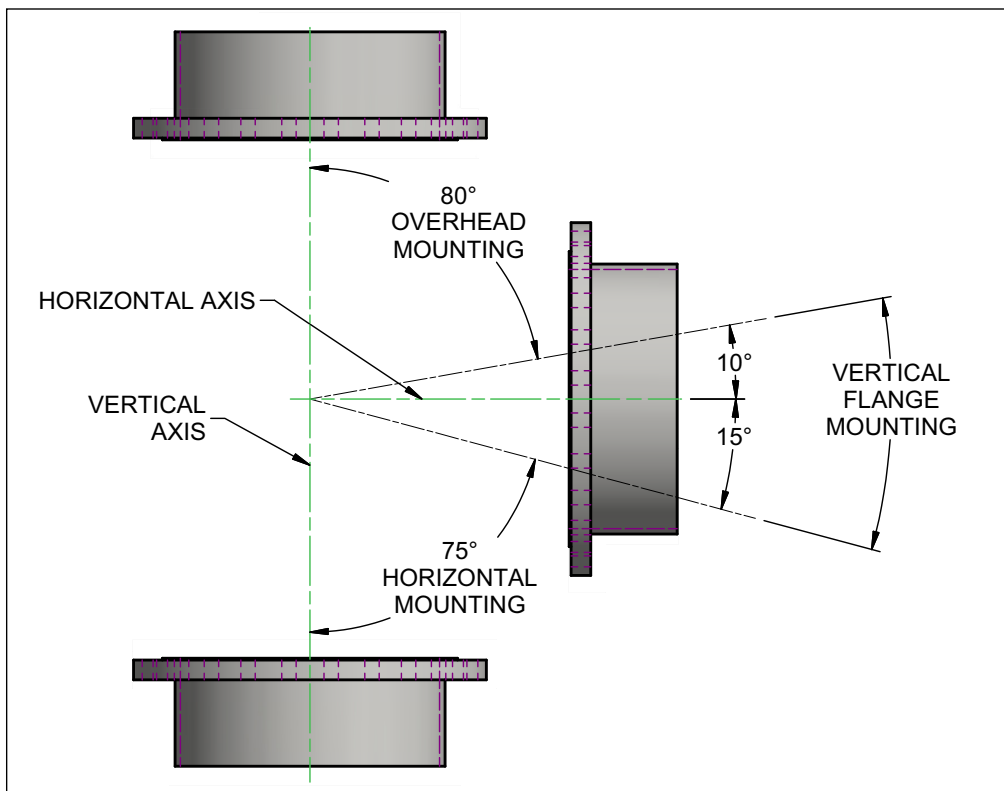

FIGURE 3-3. MOUNTING ARRANGEMENTS

3.3.1 Horizontal mounting

The hazard with horizontal mounting is the machine falling down until it hits the bridge weldment.

Mitigations include one of the following arrangements:

- Leave the setup fingers in place on the top of the leveling feet.
- If the setup fingers must be removed, block the machine up from below or secure the machine to anchor points above the machine using a minimum of two opposite swivel hoist rings with the customer-supplied anchor points and slings rated for the machine weight and sling angle. See Figure 3-3.

3.3.2 Vertical mounting

The hazard with vertical mounting is the machine falling off the flange.

Mitigations include one of the following arrangements:

- Install the setup fingers on the back of the flange, on the “bottom” of the leveling feet (see Figure 3-4).

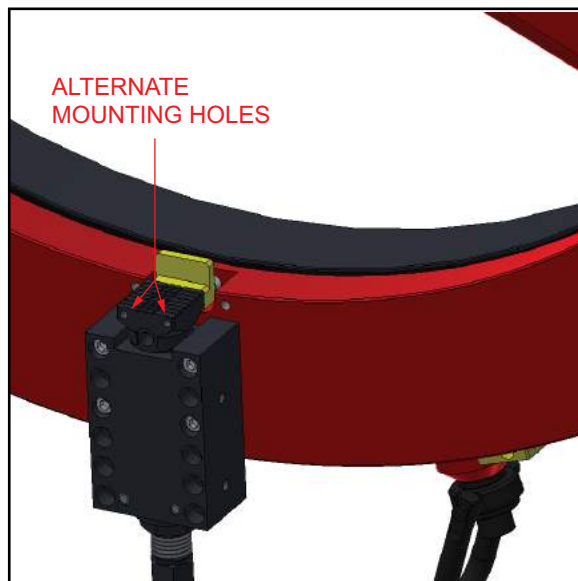

FIGURE 3-4. ALTERNATE MOUNTING HOLES

- If the flange is too thick to allow for the use of the setup fingers, secure the machine to anchor points above the machine using a

minimum of one swivel hoist ring with the customer-supplied anchor points and slings rated for the machine weight and sling angle. See Figure 3-3.

3.3.3 Overhead mounting

The hazard with overhead mounting is the machine falling off the flange.

Mitigations include one of the following arrangements:

- Install the setup fingers on the back (top) of the flange, on the “bottom” of the leveling feet (see Figure 3-4).

- If the flange is too thick to allow for the use of the setup fingers, secure the machine to anchor points above the machine using a minimum of two opposite swivel hoist rings with the customer-supplied anchor points and slings rated for the machine weight and sling angle. See Figure 3-3.

CAUTION

In all cases, these safety measures should be considered during the risk assessment and the machine restraints installed snug so that any swinging or other machine movement is kept to an absolute minimum.

3.4 MACHINE ASSEMBLY

Do the following to set up the ODF50 Speed Facer:

1. Complete the risk assessment checklist in Table 1-2 on page 5.
2. Measure the OD of the flange to be machined.
3. Position the machine on a solid support for installing the eight mounting feet according to Table 3-1.

WARNING

Failure to properly mount and tether the machine may allow the machine to rotate or fall.

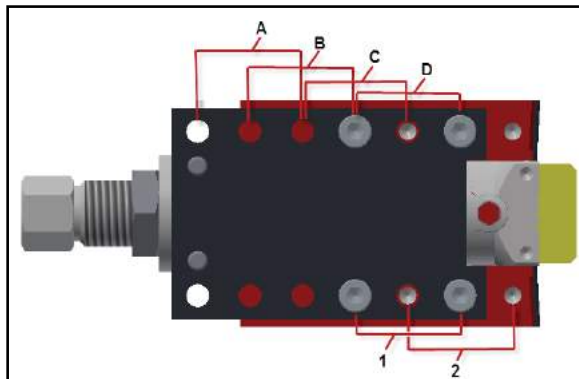

FIGURE 3-5. BOLT AND HOLE LOCATIONS

TABLE 3-1. ODF50 MOUNTING FEET

Minimum OD in inches (mm)	Maximum OD in inches (mm)	Foot bolt location	Frame hole location
47.02 (1,194)	50.5 (1,283)	D	1

TABLE 3-1. ODF50 MOUNTING FEET

Minimum OD in inches (mm)	Maximum OD in inches (mm)	Foot bolt location	Frame hole location
45.02 (1,143)	48.5 (1,232)	C	1
43.02 (1,093)	46.5 (1,181)	C	2
41.02 (1,042)	44.5 (1,130)	B	2
39.02 (991)	42.5 (1,080)	A	2

4. Center the jacking leveling jaw with the jacking leveling ram on the leveling foot assemblies.
5. Roughly adjust the leveling feet (one shown in Figure 3-6) by turning the jacking foot screw until approximately .125" (3 mm) larger than the flange OD.

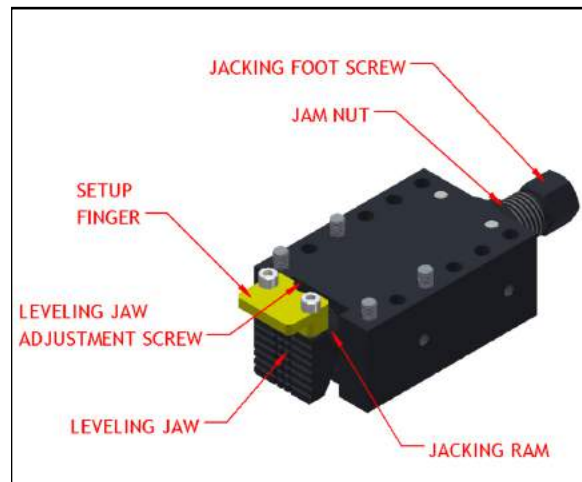

FIGURE 3-6. LEVELING FOOT COMPONENTS

NOTICE

Jacking leveling and standard jaws only have 1.7" (43 mm) of travel.

6. Rig the machine onto the flange by placing the setup fingers against the bolting flange surface.
7. Tighten the leveling feet screws equally until the jaws are against the flange OD with 10 ft-lbs (14 Nm) of torque.

3.4.1 Chuck foot spacers

Each chuck foot spacer provides 1.97" (50.03mm) of clearance off the face of the workpiece. Two can be used on each mounting foot.

Do the following to install the chuck foot spacers:

1. Securely position the machine to allow access to the mounting feet.
2. Remove the mounting foot noting the frame hole location being used.
3. Remove existing fasteners noting the mounting holes being used.
4. Install the supplied fasteners in the mounting foot using the same mounting holes.
5. Stack either one or two chuck foot spacers on top of the mounting foot and over the fasteners.
6. Reinstall the mounting foot to the machine using the same frame hole location.
7. Repeat for all mounting feet.



FIGURE 3-7. CHUCK FOOT SPACERS

3.4.2 Centering and leveling

Do the following to center and level the machine:

1. For coarse adjustment, check the distance between the inner diameter (ID) of the machine and the OD of the pipe with a tape measure at the four leveling feet.
2. For fine adjustment, use a dial indicator in the tool holder to check the same measurements between the ID of the machine and the OD of the pipe. Adjustment in both cases is made with the jacking foot screws.
3. As the setup fingers achieve the initial leveling, do the following to fine tune the level:
 - a) Mount a dial indicator in the tool holder centered over the raised flange surface.
 - b) Zero out the indicator over the first leveling foot and rotate the machine 180° to position the indicator in-line with the opposing foot.
 - c) Using the leveling jaw adjustment screw, raise or lower the jaw half the difference between the two feet.
 - d) Repeat step b and step c for the remaining leveling feet. Typical applications require machine alignment within .010" (.25 mm) or less.

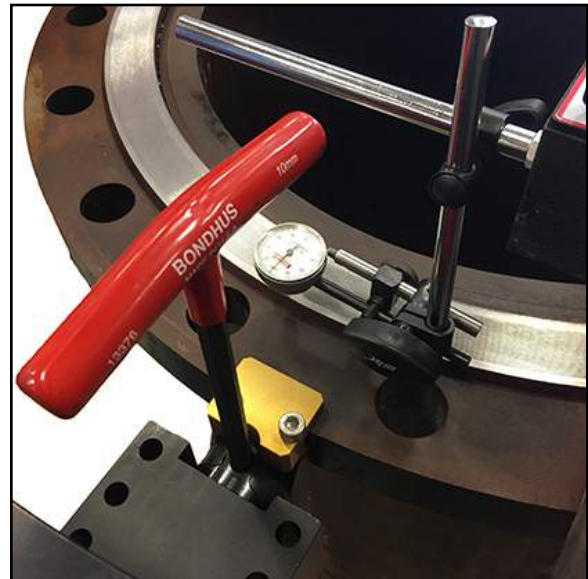

FIGURE 3-8. DIAL INDICATOR MOUNTED FOR LEVELING

4. Alternating between the four adjustable jacking feet, torque to 140 ft-lbs (190 Nm).

WARNING

Be sure to tighten the jacking feet to 140 ft-lbs (190 Nm) minimum. Insufficient clamping force may allow the machine to fall from the workpiece, which may result in machine damage or personnel injury or death.

NOTICE

Do not over-tighten the jacking feet screws. Over-tightening could warp the machine rotational frame and cause undesirable machining results.

5. Alternating between the four non-leveling feet, torque to 140 ft-lbs (190 Nm).
6. Tighten the jam nuts on all jacking feet.
7. Remove the setup fingers from the leveling feet, if necessary to machine completely to the OD. See the subsections of Section 3.3 on page 14 for information for securing the machine.

3.4.3 Installing the cutting bit or insert holder

NOTICE

The ODF50 Speed Facer is designed to trail the cutting tool behind the bridge weldment. Refer to the rotational direction label on the machine when installing the cutter.

Do the following to install the cutting bit or insert holder:

1. Adjust the tool holder to the correct position for the start of machining.

2. Adjust the tool holder to the desired swivel angle (see Figure 3-9).



FIGURE 3-9. LOCATION OF SWIVEL CLAMPING SCREW

3. To install the appropriate tool in the swivel tool post: Loosen the M20 tool clamp screw, insert the cutting tool, and tighten the M20 screw.
4. If using .50" (12.7mm) square tooling install the .50" tooling adapter against the top of the swivel tool post slot. The channel in the tooling adapter accepts the .50" square cutting tool.



FIGURE 3-10. .50" TOOL ADAPTER INSTALLED (P/N 89175)

5. Set the tool to the desired cutting depth.

TIP:

Always insert the cutting tool as far as possible into the tool holder for stability.

3.4.4 Installing the offset tool holder

The offset tool holder is reversible to allow additional clearance on both OD and ID operations.

Do the following to install the offset tool holder onto the swivel tool post:

1. Remove any tool that may be installed in the swivel tool holder.
2. Slide the offset tool holder onto the swivel tool post.
3. Insert the bar tool clamp in the slot of the swivel tool holder in place of tooling.
4. Adjust the angle and position of the offset tool holder for the process.
5. Tighten the M20 tool clamp screw to secure.
6. The cutting tool can now be installed in the offset tool holder with the cutting edge facing the rotation direction of the machine. Secure with the four fasteners.



FIGURE 3-11. OFFSET TOOL HOLDER (P/N 89203)

7. To reverse the position of the offset tool holder, do the following:
 - a) Loosen the M20 tool holder screw.
 - b) Rotate the tool holder approximately 180°.
 - c) Tighten the M20 tool holder screw.
 - d) Remove and flip the cutting tool with the cutting edge facing the rotational direction of the machine.

3.4.5 Rotating the tool head

Do the following to rotate the tool head:

1. Loosen the two swivel clamping screws to free the circular clamp collar on the back of the tool head.

CAUTION

Do not loosen the tool head rapidly. Keep your hand on the tool head for stability. Quick disengagement of the tool head can cause it to swing unexpectedly, and may result in personnel injury or machine damage.

2. Position the tool head.
3. Secure the clamp collar by tightening the two swivel clamping screws.

Engraved markings on the clamp collar enable setting angles within $\pm 0.5^\circ$.

3.4.6 Adjusting the feed

NOTICE

The feed unit can be placed on either the radial or axial slides depending if the machining operation is facing or boring.

Do the following to adjust the feed:

1. Install the feed trippers as required (see Figure 3-12).

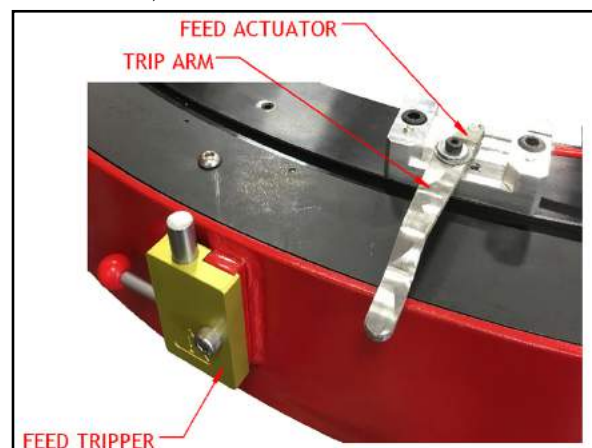

FIGURE 3-12. FEED TRIPPER LOCATION

TIP:

The number of feed trippers determines the feed rate and desired finish. Four feed trippers are included. The feed box is adjustable from .001-.008" (.003-.2 mm) of revolution per trip. Finer finishes typically use one or two feed trippers with the feed adjustment set small per trip. Coarse or faster finishes use all four feed trippers.

2. Set the feed direction according to the following steps, as shown in Figure 3-13:
 - a) Push the feed direction knob in to engage the feed toward the center.
 - b) Pull out the feed direction knob out to engage feed toward the OD.

TIP:

It may be necessary to slightly twist the knob when changing the feed direction.

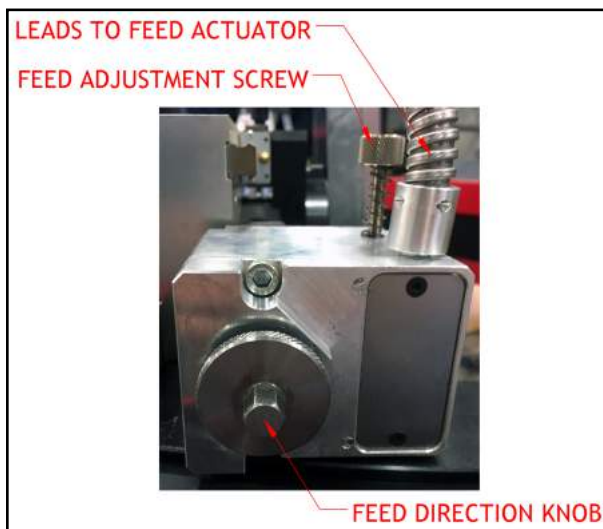

FIGURE 3-13. FEED ADJUSTMENTS

3. Set the feed amount per trip.

NOTICE

When the feed adjustment screw is unscrewed the maximum amount, feed is at the maximum amount of approximately .008" (.2 mm) per trip. When the feed adjustment screw is screwed in, the feed is at the minimum. Adjusting the thumb screw will change the angle of the trip arm on the feed actuator.

4. Route and secure the feed cable to prevent it from kinking or catching on any obstructions.

3.4.7 Installing the drive motor

Red-blue labels (P/N 60219, 60220 shown in Table 1-4 on page 6) on either side of the machine that the air motor is installed on shows the hose arrangement for correct motor run direction.

For example, when the motor is installed on the top, the red hose connects to the red motor port. See Figure 3-14.

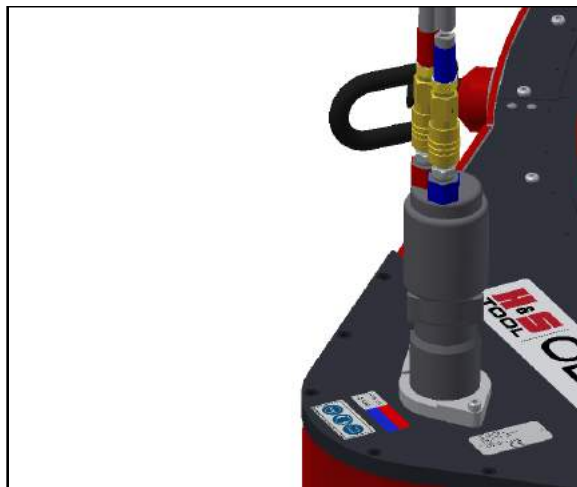

FIGURE 3-14. INSTALLED AIR MOTOR DRIVE

Do the following to install the drive motor:

1. Check that the drive key is present in the slot of the motor shaft.
2. Fit the motor drive shaft into the drive hub, aligning the drive key with the slot in the drive hub.
3. Tighten the two screws on the mounting collar to secure.

3.4.8 Connecting the Air Caddy

Connect the Air Caddy to the machine using the speed adjustment valve disconnect.

4 OPERATION

IN THIS CHAPTER:

4.1 PRE-OPERATION CHECKS - - - - - 21

4.2 OPERATION MODES - - - - - 21

 4.2.1 CONFIGURING FOR FLANGE FACING - - - - - 21

 4.2.2 CONFIGURING FOR A COUNTERBORE - - - - - 22

 4.2.3 CONFIGURING FOR THE BACKFACING ATTACHMENT - - - - - 22

4.3 OPERATION - - - - - 23

 4.3.1 STARTING THE MACHINE - - - - - 23

 4.3.2 STOPPING THE MACHINE - - - - - 24

 4.3.3 ADJUSTING THE MACHINE SETTINGS - - - - - 24

4.1 PRE-OPERATION CHECKS

Do the following checks before operating the machine:

1. Complete the risk assessment checklist in Table 1-3 on page 5.
2. Check that the work area is clear of non-essential personnel and equipment.
3. Check that the machine control/observation area will not be in the path of hot flying chips during machine operation.
4. Check the machine is securely mounted to the workpiece, according to Section 3.3 on page 14.
5. Check that air hoses are routed and secured to avoid tripping, entanglement, damage from hot chips, or other damage should an air hose or connection fail.
6. Check the tool condition and sharpness.
7. On the Air Caddy, check that the oil drip rate is set to six drips per minute.
8. Check that all hand tools are removed from inside the machine and the work area.

4.2 OPERATION MODES

The ODF50 Speed Facer can machine a face, groove, or bevel on a flat or tapered flange. The following subsections explain how to set up the machine for these operating modes. See Section 2.2 on page 10 for controls information.

4.2.1 Configuring for flange facing

Flat facing is the default operating mode of the ODF50 Speed Facer.



Do not configure or adjust the machining direction unless the machine is turned off, the air hose has been disconnected, and any required lockout/tag out has been performed.

To configure the ODF50 Speed Facer for machining a face on a flat flange, complete the following steps:

1. Assemble the ODF50 Speed Facer on the workpiece (see Section 3.3 on page 14).
2. Complete all pre-operation checks (see Section 4.1).

- Loosen both the radial and axial gib lock screws.

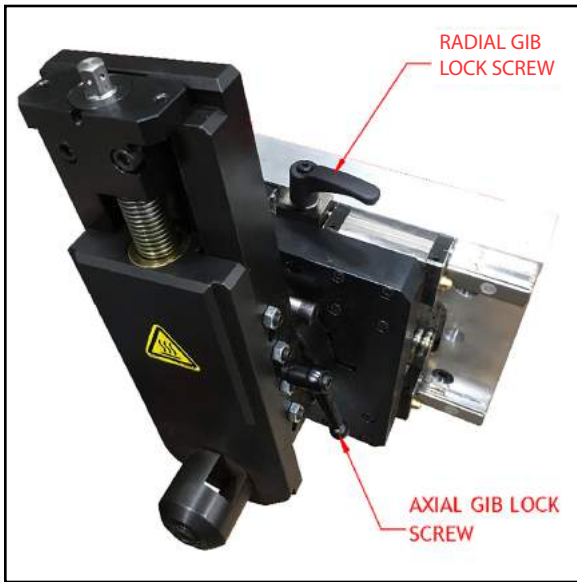

FIGURE 4-1. GIB LOCK SCREWS

- Use a 3/8" ratchet driver on the radial and axial feed screws to position the cutting tool to the starting point of the cut.
- Hand tighten only the axial gib lock screw.
- Set the feed direction knob (shown in Figure 4-5 on page 24) to the desired direction.
- Set the feed rate, referencing Section 3.4.6 on page 19 and using the feed adjustment screw on the feed box.

4.2.2 Configuring for a counterbore

Do the following to configure for a counterbore:

- Assemble the ODF50 Speed Facer on the work-piece (see Section 3.3 on page 14).
- Complete all pre-operation checks (see Section 4.1).
- Reposition the feed box from the radial feed screw to the axial feed screw, securing it with two screws.
- Loosen both the axial and radial gib lock screws.
- Use a 3/8" ratchet driver on the radial and axial feed screws to position the cutting tool to the starting point of the cut.
- Hand tighten only the radial gib lock screw.
- Set the feed direction knob to the desired position. In this configuration, pressing the feed direction knob in feeds the cutting bit away from the operator.

- Set the feed rate, referencing Section 3.4.6 on page 19 and using the feed adjustment screw on the feed box.

4.2.3 Configuring for the backfacing attachment

The ODF50 Speed Facer can also be configured with the optional backfacing attachment. This configuration allows flange facing when there are obstructions running through the pipe and also allows machining of the backside of the bolting flange.

Do the following to configure the machine for backfacing:

- Remove the bridge weldment from the machine. Observe the posted masses and use proper lifting and moving procedures, as described in Section 3.2 on page 13.

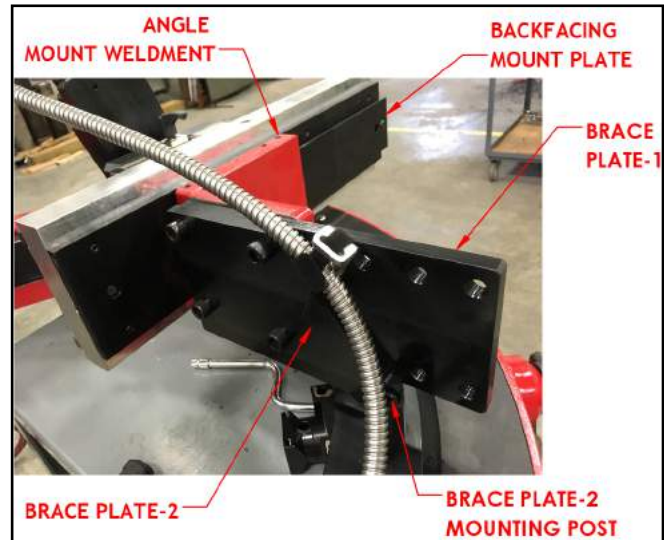

FIGURE 4-2. BACKFACING COMPONENTS

- Remove the radial slide assembly from the bridge weldment and install it onto the backfacing mount plate.
- Install the angle mount weldment onto the machine.
- Install brace plate-2 onto the machine using the mounting post but do not tighten fully.
- Install two M12 x 1.75 x 25mm fasteners through the two non-tapped holes on the end of brace plate-1 and secure to the angle mount weldment using the corresponding holes. Swing brace plate-2 into position against brace plate-1 and secure with four M12 x 1.75 x 25mm fasteners.
- Fully tighten the fastener holding brace plate-2 to the machine.

7. Reposition the counterweight to oppose the backfacing attachment by shifting it counter-clockwise to the next series of three holes.
8. To reposition the feedbox from the radial slide to the axial slide do the following:
 - a) Loosen the two screws on the face of the feedbox.
 - b) Pull out on the feedbox to free it from the drive shaft of the radial slide.
 - c) Install the feedbox on the end of the axial slide shaft and secure by tightening the two screws.

9. Reposition a clip and Velcro strap to an empty hole on brace plate-1 and secure the trip cable.

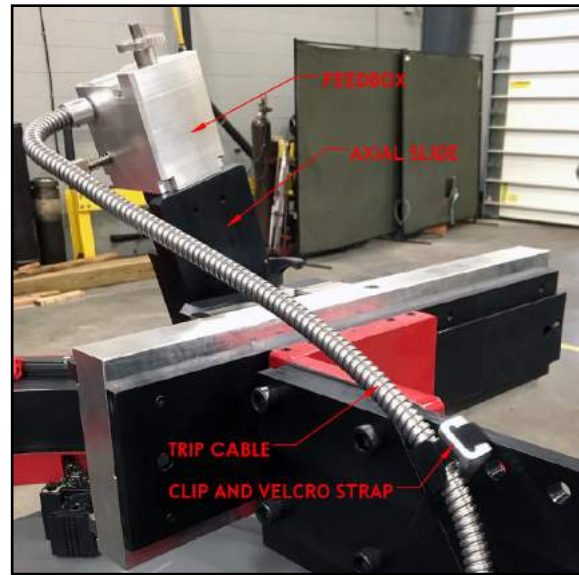

FIGURE 4-3. REPOSITIONED BACKFACING COMPONENTS

4.3 OPERATION

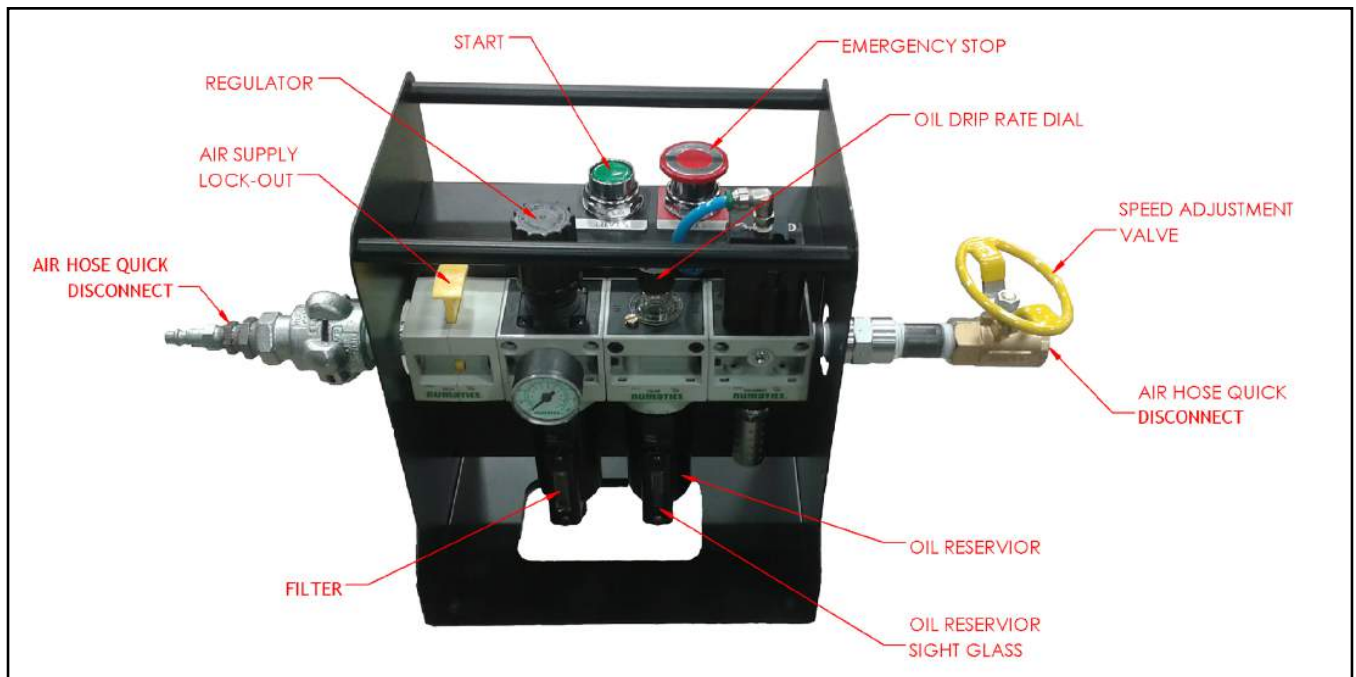

FIGURE 4-4. AIR CADDY CONTROLS

4.3.1 Starting the machine

Do the following to start the machine:

1. Complete these steps on the Air Caddy (shown in Figure 4-4):

- a) Open the AIR SUPPLY LOCK-OUT valve.
- b) Pull up the EMERGENCY STOP button.
- c) Press the START button.

- d) Slowly open the SPEED ADJUSTMENT valve until the rotary speed reaches the desired rate.
2. Engage the number of feed trippers required for the finish type (see Section 3.4.6 on page 19).

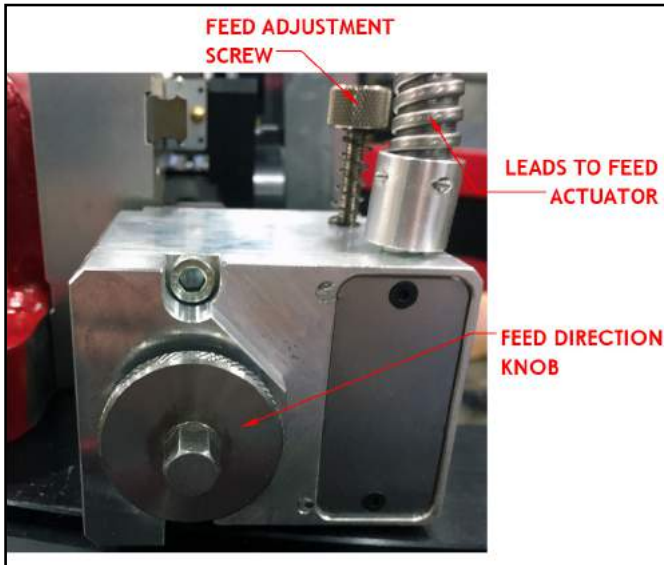

FIGURE 4-5. FEED ADJUSTMENT SCREW AND FEED DIRECTION KNOB

3. To adjust the feed rate: Stop the machine (see Section 4.3.2 on page 24), then fine-tune the feed adjustment screw setting based on the initial cut rate.
4. Adjust the feed rate and rotary speed as necessary to maintain the desired cut.
5. Adjust the oil drip rate as needed (see Figure 4-4).

NOTICE

For best machine performance and service life, H&S recommends a minimum Air Caddy oil drip rate of six drips per minute.

4.3.2 Stopping the machine

Do the following to stop the ODF50 Speed Facer:

1. Disengage the feed trippers (see Figure 3-12 on page 19).
2. Turn the SPEED ADJUSTMENT valve clockwise to close it.
3. Press the AIR SUPPLY LOCK-OUT valve down to close it (seen in Figure 4-4). This will release residual air pressure in the Air Caddy circuit.

4.3.3 Adjusting the machine settings

Do the following to manually adjust the cutting tool position or angle:

1. Disengage the feed trippers (see Figure 4-5).
2. Stop and lock out the machine (see Section 4.3.2).
3. Manually adjust the cutting tool position or angle (see Section 3.4.2 on page 17 and Section 3.4.3 on page 18).

WARNING

Do not attempt to manually adjust the cutting tool angle or change the feed box settings during operation. Attempting to operate the feed box controls by hand or with hand tools while the machine is running may result in severe injury.

5 MAINTENANCE

IN THIS CHAPTER:

5.1 MAINTENANCE CHECKLIST	25
5.2 APPROVED LUBRICANTS	25
5.3 MAINTENANCE TASKS	26
5.3.1 CHECKING THE AIR CADDY OIL RESERVOIR AND PARTICULATE FILTER TRAP	26
5.3.2 CHECKING THE AIR CADDY DROP-OUT CIRCUIT	26
5.3.3 TESTING THE EMERGENCY STOP	27
5.3.4 DOVETAIL WAYS	27
5.3.4.1 RADIAL DOVETAIL WAYS	27
5.3.4.2 AXIAL DOVETAIL WAYS	27
5.3.5 LUBRICATING THE ROLLER BEARING	27
5.3.6 BELT ADJUSTMENT AND REPLACEMENT	27
5.3.7 GUARD INSTALLATION AND REMOVAL	28
5.3.8 ROLLER ADJUSTMENT	28
5.3.9 TRIP CABLE REPLACEMENT	29
5.3.9.1 CABLE REMOVAL	29
5.3.9.2 CABLE PREPARATION	30
5.3.9.3 CABLE INSTALLATION	30
5.4 TROUBLESHOOTING	31
5.4.1 THE MACHINE ISN'T TURNING	31
5.4.2 THE MACHINE ISN'T FEEDING	31
5.4.3 THE MACHINE IS PERFORMING POORLY	31
5.4.4 THE MACHINE ISN'T CUTTING FLAT	31

5.1 MAINTENANCE CHECKLIST

Table 5-1 lists maintenance intervals and tasks.

TABLE 5-1. MAINTENANCE INTERVALS AND TASKS

Interval	Task	Reference
Before each use	Check the Air Caddy oil reservoir level and particulate filter trap.	5.3.1
	Check air lines for damage and wear.	--
	Check the cutting tool for sharpness. Replace as necessary.	5.4.3
	Perform a Air Caddy drop-out circuit check.	5.3.2
Before and after each use	Remove debris, oil, and moisture from machine surfaces.	--
Every ten operation cycles	Lubricate the radial and axial feed dovetail ways.	5.3.4
During use	Lubricate the roller bearings	5.3.5

5.2 APPROVED LUBRICANTS

H&S recommends using the following lubricants at the locations indicated.

Failure to use the appropriate lubricants can result in damage and premature machine wear.

CAUTION

Avoid damage, premature machine wear, and protect your warranty by using only approved lubricants.

TABLE 5-2. APPROVED LUBRICANTS

Application Area	Lubricant	Biodegradable Lubricant	Viscosity (cSt)	Quantity	Frequency
Daily					
Rectangular & Dove-tail Ways ^a	Mobil Vactra Oil Heavy Medium	N/A	>68 @ 40C	As required	Daily during machine use
Each Use					
Air Caddy	Unax AW 32	N/A	22-68 @ 40° C 4.3-8.7 @ 100° C	Refill oil lubricator	Each use
Unpainted Surfaces	LPS1 or LPS2	N/A	38 @ 25C	As required	Each use, and before storage
Bearing surface of track ring	LPS All-Purpose Anti-Seize Platinum Grade	N/A	N/A	As required	Weekly during machine use
Weekly					
Lead screw on single point tool head	NOOK E-100 spray lube NOOK PAG-1 grease	CASTROL BioTac EP 2	96 @ 40C 113 @ 100C	Light coating applied by hand or spray	Weekly during machine use
Jacking feet	Moly Grade Anti-Seize	N/A	N/A	1 cc per screw	Weekly during machine use, and before storage
During Use					
Bearing surface of track ring	ThermaPlex LPS bearing grease	N/A	N/A	6 strokes with a standard lube gun	Hourly during use

a. Use highly anti-corrosive, refined mineral or synthetic oil that forms a strong oil film and is not easily emulsified or washed away by coolant. Hydraulic oils are typically not suitable for slide way lubrication.

5.3 MAINTENANCE TASKS

Maintenance tasks are described in the following sections.

5.3.1 Checking the Air Caddy oil reservoir and particulate filter trap

Do the following to check the Air Caddy oil reservoir and particulate filter trap:

1. Check the Air Caddy oil reservoir sight glass (see Figure 4-4 on page 23). Refill as necessary.
2. Check the Air Caddy particulate filter trap sight glass. Empty as necessary.

5.3.2 Checking the Air Caddy drop-out circuit

The Air Caddy drop-out circuit prevents the machine from restarting unexpectedly after the air supply to the Air Caddy is lost and restored.

Do the following to check the Air Caddy drop-out circuit:

1. Check that the Air Caddy is connected to a shop air supply and the ODF50 Speed Facer.
2. Check that the air-supply lock-out is open (that is, pulled up). See Figure 4-4 on page 23.

3. Press the **START** button.
4. Slowly open the Air Caddy speed adjustment valve until the rotary drive engages.
5. Close (by pressing down) the **AIR SUPPLY LOCK-OUT** valve.
6. Check that the ODF50 Speed Facer stops.
7. Open the **AIR SUPPLY LOCK-OUT** valve.
8. Check that the machine does not start.

5.3.3 Testing the emergency stop

Do the following to test the emergency stop:

1. With the machine running, press the **EMERGENCY STOP** button.
2. Check that the machine stops.
3. Reset the **EMERGENCY STOP** by pulling the button up.
4. Check that the machine does not re-start.

5.3.4 Dovetail ways

5.3.4.1 Radial dovetail ways

Do the following to perform maintenance on the radial dovetail ways:

1. On the slide assembly, use the radial feed screw to move the tool head to one end of the radial feed track.
2. Wipe down the exposed dovetail ways and lubricate them with Mobil VACTRA medium heavy way oil or equivalent.
3. Move the tool head assembly to the other end of the radial feed track.
4. Wipe down the remaining exposed dovetail ways and lubricate them with Mobil VACTRA medium heavy way oil or equivalent.

5.3.4.2 Axial dovetail ways

Do the following to perform maintenance on the axial dovetail ways:

1. On the slide assembly, use the axial feed screw to move the tool slide to one end of the axial feed track.
2. Wipe down the exposed dovetail ways and lubricate them with Mobil VACTRA medium heavy way oil or equivalent.
3. Move the tool slide to the other end of the axial feed track.
4. Wipe down the remaining exposed dovetail ways and lubricate them with Mobil VACTRA medium heavy way oil or equivalent.

5.3.5 Lubricating the roller bearing

Should the SpeedFacer require it, do the following to lubricate the roller bearings during use:

1. Attach the grease gun nozzle to the grease fitting on the side of the machine.
2. Start the machine and bring it to normal operating speed.
3. Apply approximately 1/4 oz or 6 squeezes from a 14oz grease gun of ThermaPlex LPS bearing grease.
4. Allow the machine to continue to rotate several times to evenly distribute the grease.
5. Stop the machine and remove the grease gun.



FIGURE 5-1. GREASE FITTING

5.3.6 Belt adjustment and replacement

The belts should be clean, dry, and properly tensioned. Belts that are broken, frayed, or otherwise damaged must be replaced.

NOTICE

Always replace both belts together.

To check belt tension, do the following:

1. Remove the two 1/4 NPT pipe plugs from the side of the frame.
2. Use a 1/4" (6 mm) rod or similar with a smooth square to push against each belt. The belt should displace approximately 1/4" for 5 lbs of force (6 mm for 2.3 kg of force).

To adjust the belt tension, do the following:

1. Remove the guard closest to the drive motor.

2. Loosen the M12 screw clamping the idler pulley position.
3. Adjust the tensioning set screw to reach the desired tension.
4. Retighten the M12 SHCS.
5. Replace the guard.

5.3.7 Guard installation and removal

Do the following to remove the guarding for maintenance procedures:

1. Unscrew all the M8 screws until they are free from the posts.
2. Locate a M8 screw central to one of the guard sections.
3. Place the closed end of a 9/16" box wrench over the screw head at an angle that traps it against the guard.



FIGURE 5-2. BOX WRENCH OVER SCREW

4. Quickly pull the wrench up and out to remove the guard.
5. Repeat step 2 through step 4 for the remaining guard sections.

After maintenance work, do the following to install the guard:

1. If still present, remove all M8 screws from the guard sections.
2. Place the first of the guard sections in the proper position on the machine.

3. In the center of the guard, insert two 3/16" punches (or similar) through the holes in the guard into the posts below. Larger machines may require the process to start at one end rather than centrally.



FIGURE 5-3. PUNCHES USED FOR GUARD INSTALLATION

4. Lever the punches toward the inside of the machine, pulling the guard into position. At the same time, strike the face of the guard with a soft face mallet.
5. Repeat steps 2-4 for the remaining guard sections.
6. Reinstall and tighten all M8 screws.

5.3.8 Roller adjustment

While the machine is operating, each roller should rotate approximately two-thirds of the time. If the rollers are set too tight, the machine will bind. Ideal setup allows the machine to be rotated by hand power.

WARNING

Roller adjustment requires the machine to operate without the guarding in place. Never attempt to adjust the rollers while the machine is rotating, as this could cause serious injury or death.

Do the following to adjust the rollers:

1. Place the machine in the horizontal position, well supported across its diameter. Do not mount on a flange while adjusting the rollers.
2. Remove all guarding (See Section 5.3.7 on page 28.), the air motor and trip actuator.
3. Start the adjustment procedure at the four rollers located nearest to the mounting feet. These will be at about 90° to each other.

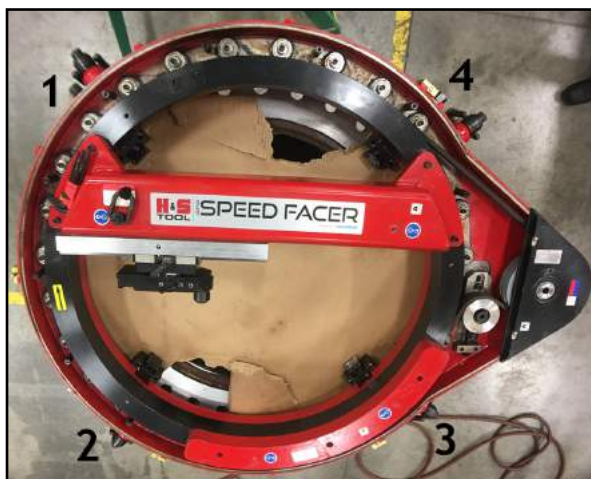

FIGURE 5-4. INITIAL ROLLER BEARING LOCATIONS

4. Place the roller adjusting wrench over the eccentric bushing and loosen the lock screw with a 5/16" Allen wrench. Apply a preload to these four rollers that will allow the machine to be rotated by hand with some resistance. The recommended torque setting for the eccentric bushings at these four locations only is 7ft-lb (9.5 NM)



FIGURE 5-5. ADJUSTING AND TIGHTENING OF THE BUSHINGS AND CAP SCREWS

5. Tighten the lock screw while maintaining the position of the eccentric bushing with the adjustment wrench. The recommended torque setting for the socket head cap screws at all roller bearing locations is 50 ft-lb (67.8 Nm).
6. Reinstall the air motor and activate the machine rotation. Adjust the speed to approximately 2-4 RPM.
7. Adjust the remaining intermediate rollers to make contact with the track ring. These rollers should be adjusted 180° to each other while working around the machine. The recommended torque setting for the intermediate bearings is 3 ft-lb (4.1 Nm).

NOTICE

It is normal for some of the intermediate rollers to only rotate intermittently.



FIGURE 5-6. CHECKING FOR PLAY BETWEEN THE TRACK RING AND THE STATIONARY RING

8. Check for play between the stationary frame and the rotating track ring by inserting a pry bar device between the edge of the frame and the track ring. If movement is detected while applying pressure, repeat steps 3-7.
9. Apply anti-seize to the bearing surface of the ring gear and rollers as noted in Table 5-2.
10. Replace all guarding and the trip actuator.

5.3.9 Trip cable replacement

Do the following to replace the trip cable in the event it breaking or becoming damaged.

5.3.9.1 Cable removal

To remove the cable, do the following on the feedbox:

1. Remove the cover and set screw guarding the M4 fastener.

- Set the feed adjustment screw to maximum by turning the screw all the way in.

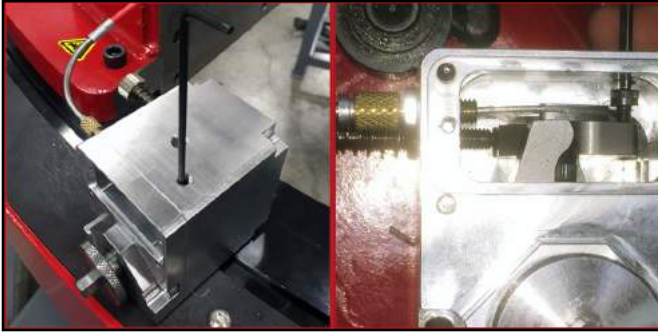

FIGURE 5-7. LOCATION OF M4 SCREW (LEFT); CABLE END UNDER M4 SCREW AND JAM NUT WITH ADJUSTING BOLT (RIGHT)

- Loosen the M4 screw to free the cable end.
- Loosen the jam nut and unscrew the adjusting bolt to free the cable from the feedbox.
- Loosen the Velcro straps to free the protective cable conduit, remove and put aside.

Do the following on the trip actuator:

- Remove the cover plate.
- Lift the barrel end of the cable up and out of the trip arm and the cable out of the slot in the actuator block.



FIGURE 5-8. BARREL END OF CABLE REMOVAL (LEFT); CABLE AND HOUSING CUTTERS (RIGHT)

5.3.9.2 Cable preparation

Do the following to prepare the cable:

- The use of a cable and jacket cutter is suggested (ParkTool #CN-10).
- Cut only the cable jacket to 38.5" (97.8 mm).
- Even with the use of a cable and jacket cutter, pinching of the internal jacket may occur. If it does, ream out with an awl or scribe before installing the cable. Install ferrules on both ends of the cable jacket by crimping.

- Thread the spring onto the cable and up against the barrel end.
- Thread the cable through the cable jacket.

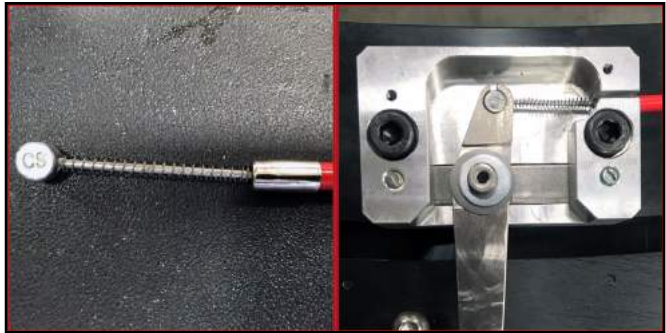

FIGURE 5-9. BARREL END OF CABLE WITH SPRING, FERRULE INSTALLED ON CABLE HOUSING (LEFT); CABLE INSTALLED IN ACTUATOR HOUSING (RIGHT)

5.3.9.3 Cable installation

To install the cable, do the following on the trip actuator (see Figure 5-9-right):

- Install the barrel end of the cable into the pocket on the trip arm.
- Trap the spring between the trip arm and the actuator body.
- Insert the cable into the slot of the actuator body.
- Reinstall the protective cable conduit over the trip cable.

Do the following on the feedbox:

- Thread the cable free cable end through the 90° elbow, adjusting bolt and jam nut.
- Screw the jam nut onto the adjusting bolt.
- Set the adjusting bolt approximately halfway into the feedbox housing.
- To determine the final length of the cable, take up the slack until the trip actuator arm is 90° to the trip actuator body. Trim the cable even with the far side of the feedbox wall.



FIGURE 5-10. 90° ELBOW, ADJUSTING NUT AND JAM NUT (LEFT); CABLE END SHOWN AT TRIMMING LOCATION (RIGHT)

5. Treat the cable end with solder to prevent fraying and the possibility of coming loose (see Figure 5-11).
6. Feed the cable end under the head of the M4 screw and tighten (see Figure 5-11).
7. Check for free movement of the mechanism by actuating the tripper arm (the feed adjustment screw may need advanced out). If interference is observed with cable end and the feedbox wall, bend the cable end away from the head of the M4 screw.

8. Secure the protective cable conduit with the Velcro straps.



FIGURE 5-11. SOLDER-TREATED CABLE END (LEFT); CABLE END SECURED UNDER THE M4 SCREW (RIGHT)

5.4 TROUBLESHOOTING

This section is intended to help you solve basic machine performance problems. For serious maintenance or if you have questions on the following procedures, contact H&S.

5.4.1 The machine isn't turning

If the machine is not rotating, check the following:

1. The power source is connected and energized.
2. The EMERGENCY STOP is reset (Section 4.3.1 on page 23 and Section 5.3.3 on page 27).
3. The air regulator is open and not broken (Figure 4-4 on page 23).
4. There is air pressure entering and leaving the Air Caddy. Check the air pressure by disconnecting the hose quick disconnects and checking for air bleed (Figure 4-4 on page 23).
5. All the valves are open (Figure 4-4 on page 23).
6. All the quick disconnects are fully engaged (Figure 4-4 on page 23).
7. Check machine movement by first checking that the power to the machine drive is isolated and locked out, then by manually rotating the machine using the handles on the bridge weldment.

5.4.2 The machine isn't feeding

If the machine isn't feeding properly, check the following:

1. The feed trippers are engaged (Section 3.4.6 on page 19).
2. The feed direction knob is either pushed in or pulled out, not in the neutral center position.

5.4.3 The machine is performing poorly

If the machine is performing poorly, check the following:

1. The tool is installed correctly (Section 3.4.3 on page 18).
2. The machine is tight to the workpiece (Section 3.3 on page 14).
3. The bridge weldment screws are secure.
4. The locking gib screws on the radial and axial slides are adjusted correctly (Section 4.2.1 on page 21 and Section 4.2.2 on page 22).
5. The swivel clamping screws on the rotating tool head are tight (Section 3.4.2 on page 17).
6. The cutting tool or insert is sharp and has the correct geometry for the material and type of cut.
7. The speed and feed rates are set correctly. If necessary, experiment with different speeds and feed rates. Typically, slower speeds and shallower cuts produce less tool chatter.
8. If the machine has been running at least an hour, the roller bearings may require lubrication.

5.4.4 The machine isn't cutting flat

If the machine is not cutting flat, do the following:

1. Before making a critical finish pass, run the machine continuously for at least 15 minutes to make sure that the machine is warmed up to operating temperature.
2. Check the machine for level (Section 3.4.2 on page 17).

-
3. Tram the tool holder to the flange face as necessary (Section 3.4.2 on page 17).

6 STORAGE AND SHIPPING

IN THIS CHAPTER:

6.1 STORAGE	33
6.1.1 SHORT-TERM STORAGE	33
6.1.2 LONG-TERM STORAGE	33
6.2 SHIPPING	34
6.3 DECOMMISSIONING	34

6.1 STORAGE

WARNING

If not properly secured, this machine can fall and cause fatal injuries to personnel. Pay special attention to vertical flange and overhead mounting installations. The machine must be properly rigged and attached to a crane or other suitable lifting apparatus before beginning any disassembly steps.

Proper storage of the ODF50 Speed Facer will extend its usefulness and prevent undue damage.

Before storing, do the following:

1. Clean the machine with solvent to remove grease, metal chips, and moisture.
2. Drain all liquids from the pneumatic conditioning unit.

Store the ODF50 Speed Facer in its original shipping container. Keep all packing materials for repackaging the machine.

6.1.1 Short-term storage

Do the following for short-term storage (three months or less):

1. Retract the tool head from the workpiece.
2. Remove the tooling.
3. Remove hoses.
4. Remove the machine from the workpiece.
5. Clean the machine to remove dirt, grease, metal chips, and moisture.
6. Spray all unpainted surfaces with LPS-2 to prevent corrosion.
7. Store the ODF50 Speed Facer in its original shipping box (see Figure 6-1).

6.1.2 Long-term storage

Do the following for long-term storage (longer than three months):

1. Follow the short-term storage instructions, but use LPS-3 instead of LPS-2.
2. Add a desiccant pouch to the shipping container. Replace according to manufacturer instructions.
3. Store the shipping container in an environment out of direct sunlight with temperature < 70°F (21°C) and humidity < 50%.

6.2 SHIPPING

The ODF50 Speed Facer can be shipped in its original shipping container, as shown in Figure 6-1.

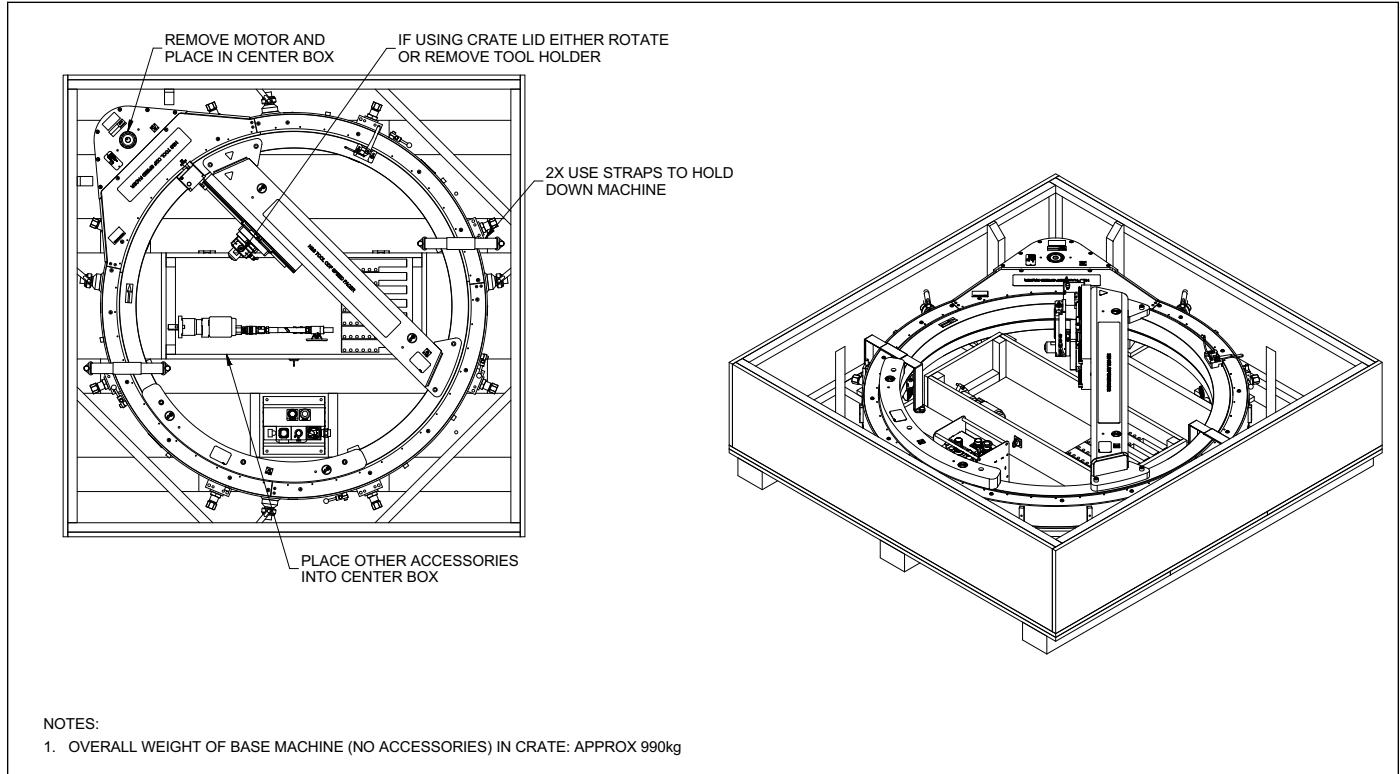

FIGURE 6-1. ODF50 CRATE

6.3 DECOMMISSIONING

To decommission the ODF50 Speed Facer prior to disposal, remove the drive assembly and dispose of it separately from the rest of the machine components. Refer to Appendix A for component assembly information.

APPENDIX A ASSEMBLY DRAWINGS

Drawing list

FIGURE A-1. ODF50 SPEED FACER ASSEMBLY (P/N 86980) - - - - -	36
FIGURE A-2. ODF50 SPEED FACER LABELS ASSEMBLY (P/N 86980) - - - - -	37
FIGURE A-3. ODF50 SPEED FACER PARTS LIST (P/N 86980) - - - - -	38
FIGURE A-4. SLIDE TOOL HOLDER ASSEMBLY (P/N 89210) - - - - -	39
FIGURE A-5. SLIDE TOOL HOLDER PARTS LIST (P/N 89210) - - - - -	40
FIGURE A-6. PNEUMATIC CONDITIONING UNIT ASSEMBLY (P/N 83430) - - - - -	41
FIGURE A-7. PNEUMATIC CONDITIONING UNIT ASSEMBLY (P/N 83430) - - - - -	42
FIGURE A-8. JACKING FOOT LEVELING ASSEMBLY (P/N 86880) - - - - -	43
FIGURE A-9. RADIAL AXIS ASSEMBLY (P/N 86890) - - - - -	44
FIGURE A-10. RADIAL AXIS ASSEMBLY PARTS LIST (P/N 86890) - - - - -	45
FIGURE A-11. PULL CABLE FEEDBOX ASSEMBLY (P/N 86900) - - - - -	46
FIGURE A-12. FEED ACTUATOR IN THE PULL CABLE FEEDBOX ASSEMBLY (P/N 86900) - - - - -	47
FIGURE A-13. FEED TRIPPER ASSEMBLY (P/N 86910) - - - - -	48
FIGURE A-14. NON-LEVELING JACKING FOOT ASSEMBLY (P/N 86970) - - - - -	49
FIGURE A-15. DRIVE MOTOR ASSEMBLY (P/N 86989) - - - - -	50
FIGURE A-16. EXTENSION FOOT ASSEMBLY (P/N 87164) - - - - -	51
FIGURE A-17. BACKFACING ATTACHMENT ASSEMBLY (P/N 87310) - - - - -	52
FIGURE A-18. CABLE PROTECTION COMPONENTS - - - - -	53
FIGURE A-19. TOOL KIT (P/N 78530) - - - - -	54

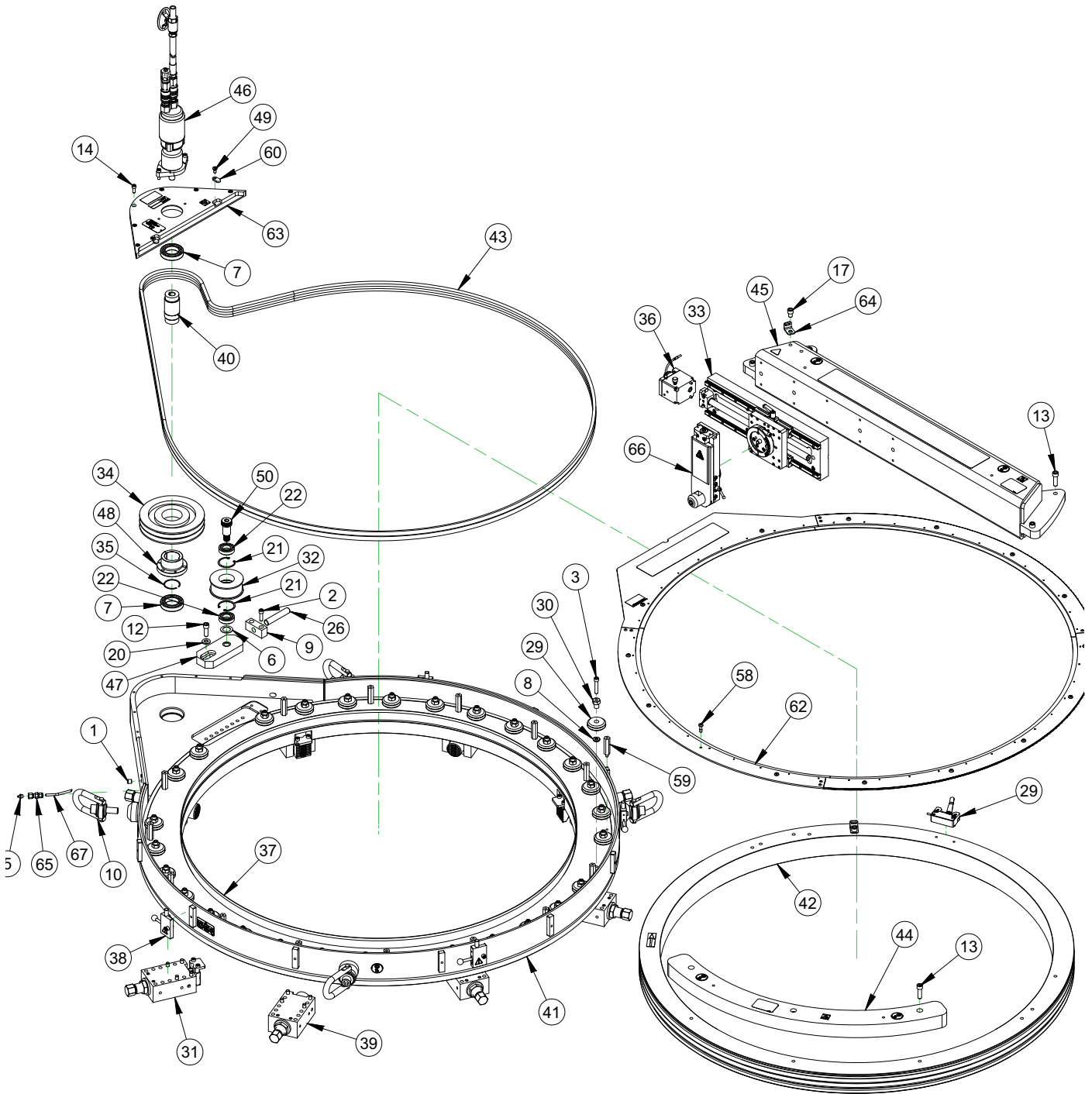

FIGURE A-1. ODF50 SPEED FACER ASSEMBLY (P/N 86980)

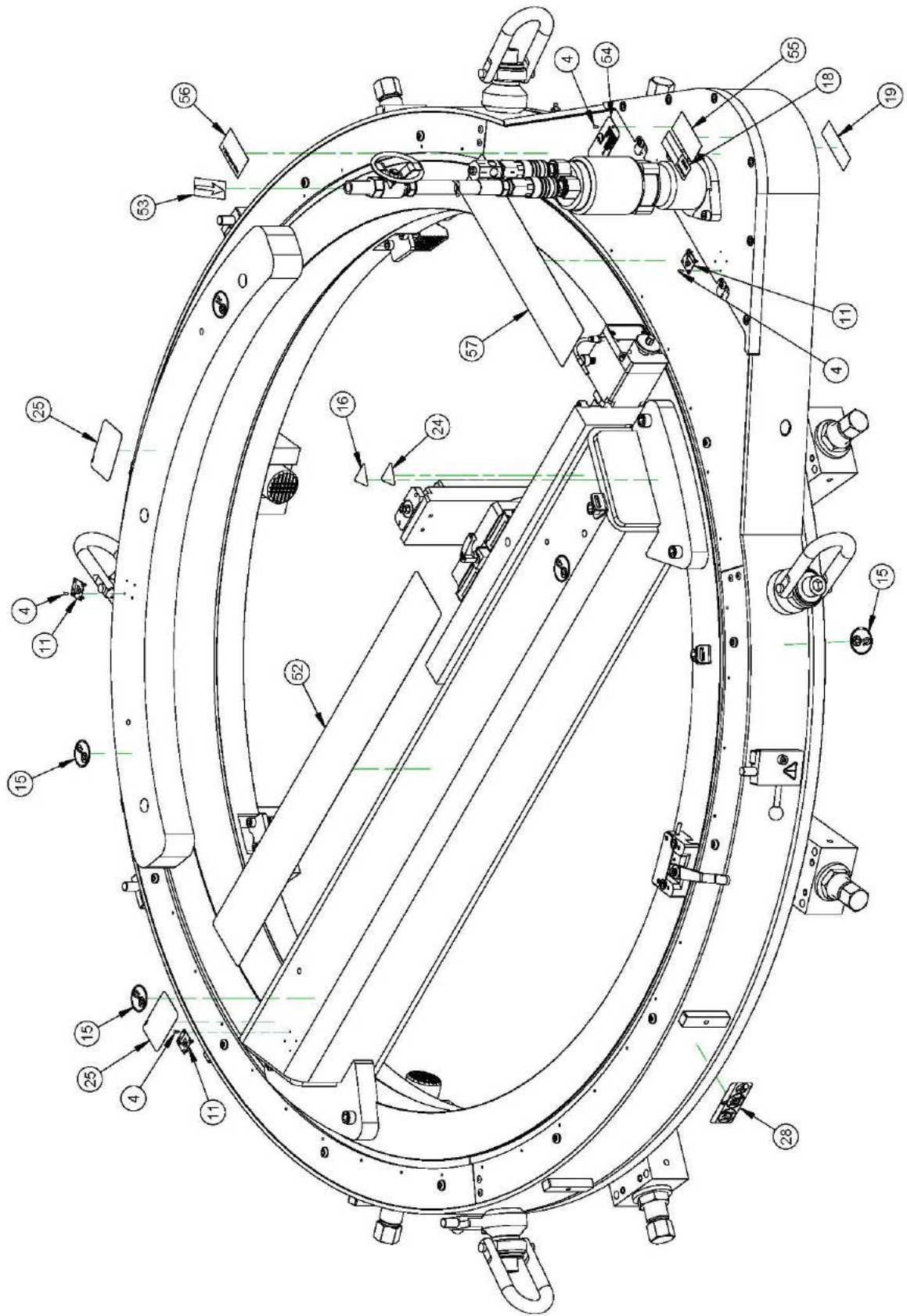

FIGURE A-2. ODF50 SPEED FACER LABELS ASSEMBLY (P/N 86980)

PARTS LIST				PARTS LIST			
ITEM	QTY	P/N:	DESCRIPTION	ITEM	QTY	P/N:	DESCRIPTION
1	2	10445	FTG PLUG 1/4 NPTM SOCKET	35	1	86997	RING SNAP 1.937 OD X .031 SINGLE TURN SPIRAL
2	1	10453	SCREW 3/8-16 X 1-1/4 SHCS	36	1	86900	ASSY FEEDBOX PULL CABLE
3	30	10557	SCREW 3/8-16 X 2 SHCS	37	160	86901	SEAL STRIP .062" THICK X 3/8" WIDE
4	14	10588	SCREW DRIVE #2 x 1/4 HOLE SIZE .089	38	4	86910	ASSY FEED TRIPPER
5	1	11898	FTG GREASE 1/8 NPTM	39	4	86970	ASSY JACKING FOOT NON-LEVELING
6	1	15079	WASHER THRUST 1.000 ID X 1.562 OD X .030	40	1	86972	SHAFT ODF DRIVE
7	2	16111	BRG BALL 1.7717 ID X 2.9628 OD X .6299 SEALS	41	1	86981	FRAME WELDMENT SF50
8	30	19236	WASHER 3/8 FLTW HARDENED	42	1	86982	RING TRACK SF50
9	1	20986	BLOCK ADJUSTING	43	2	86984	BELT V B195
10	4	22814	RING HOIST 3/4-10 X 1-1/2 5000 LB	44	1	86986	COUNTERWEIGHT SF50
11	3	29152	PLATE MASS CE	45	1	86987	WELDMENT BRIDGE SF50
12	1	30207	SCREW M12 X 1.75 X 35mm SHCS	46	1	86989	ASSY ODF DRIVE MOTOR
13	7	35215	SCREW M12 X 1.75 X 40mm SHCS	47	1	86998	PLATE TAKE UP ODF DRIVE
14	6	50458	SCREW M8 X 1.25 X 20mm SHCS	48	1	87008	BUSHING QD SK 1-15/16
15	8	59039	LABEL WARNING LIFT POINT ROUND 1.5"	49	2	87020	SCREW M8 X 1.25 X 15MM BHCS CAPTIVE 10 THD STAINLESS
16	1	59042	LABEL WARNING - HAND CRUSH/MOVING PARTS	50	1	87022	SCREW 1 DIA X 1.5 X 3/4-10 SHLDCS
17	2	59209	SCREW M12 X 1.75 X 16 mm SHCS CL 12.9 ZINC PLATED	51	1	87221	(NOT SHOWN) CRATE ODF50 74 X 74 X 21-1/4 3/4 PLY
18	1	60219	LABEL HOSE CONNECT SCHEME RED-RED/BLUE-BLUE	52	1	87260	LABEL H&S ODF50 LOGO 3.5 X 28.0
19	1	60220	LABEL HOSE CONNECT SCHEME BLUE-RED/ RED-BLUE	53	1	87265	LABEL ARROW BLK/YEL 1" X 3"
20	1	62978	WASHER M12 FLTW 27MM OD 3.1 MM THICK	54	1	87269	PLATE SERIAL YEAR MODEL BLANK CE 1.5 X 3.0
21	2	67743	RING SNAP 2.0 ID X .062 TH	55	1	87271	LABEL WARNING - EYE EAR MANUAL PROTECTION 1-3/8 X 2-3/4
22	2	67910	BRG BALL 1.000 ID X 2.000 OD X .500 2 SEALS	56	1	87272	LABEL MADE IN THE U.S.A 1.5" X 2.5"
23	1	78530	(NOT SHOWN) TOOL KIT SF SERIES	57	1	87428	LABEL H&S ODF50 LOGO 3.0 X 14.0
24	1	79324	LABEL WARNING - HAND ENTANGLEMENT/ROTATING GEARS 1.13 TALL TRIANGLE YELLOW	58	15	87473	SCREW M8 X 1.25 X 25MM BHCS CAPTIVE 10 THD STAINLESS
25	2	79385	LABEL WARNING - LIFT SUB ASSY ONLY GRAPHIC 2 X 3	59	15	87519	POST 17MM HEX X 62MM M8 X 1.25 TAPPED AND THRD EACH END
26	1	79635	SCREW 3/4-10 X 4 SSSFP	60	2	87521	CLIP RETAINER
27	1	83430	(NOT SHOWN) PNEUMATIC CONDITIONING UNIT W/SHEET METAL STAND	61	1	87522	(NOT SHOWN) MANUAL INSTRUCTION 7432 ODF50 SPEEDFACER
28	2	84855	LABEL DANGER - ODF5 TETHER MACHINE BEFORE USE	62	1	87538	GUARD AND SEAL ASSY SF50
29	30	86878	ROLLER W4	63	1	87539	PLATE COVER DRIVE ODF50
30	30	86879	BUSHING ECCENTRIC SIZE 4	64	2	89174	CLIP FORMED 1/8 X 1 SS304
31	4	86880	ASSY JACKING FOOT LEVELING	65	1	89192	FTG BULKHEAD 1/8 NPTF X 1/4 TUBE
32	1	86889	IDLER TAKE UP ODF DRIVE	66	1	89210	ASSY SLIDE TOOL HOLDER LONG ODF
33	1	86890	ASSY RADIAL AXIS 356MM TRAVEL	67	1	90117	TUBE GREASE 1/4 OD ODF50
34	1	86894	SHEAVE SIZE B 2 GROOVE 8.35 OD QD BORE				

FIGURE A-3. ODF50 SPEED FACER PARTS LIST (P/N 86980)

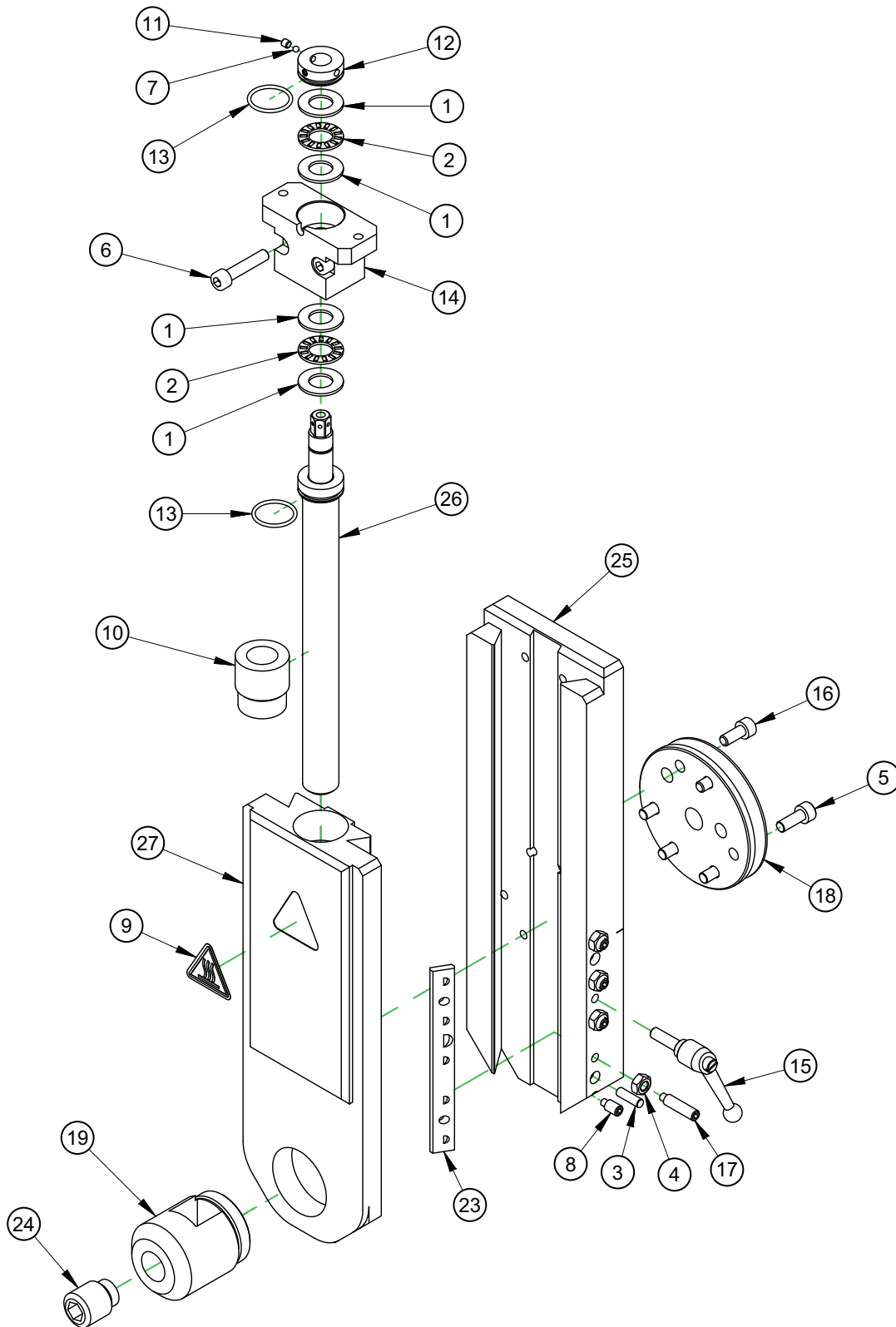

FIGURE A-4. SLIDE TOOL HOLDER ASSEMBLY (P/N 89210)

PARTS LIST			
ITEM	QTY	P/N:	DESCRIPTION
1	4	10436	WASHER THRUST .500 ID X .937 OD X .060
2	2	10437	BRG THRUST .500 ID X .937 OD X .0781
3	2	16953	PIN DOWEL 3/16 DIA X 5/8
4	4	20772	NUT M6 X 1.0 STDN ZINC PLATED
5	4	35014	SCREW M6 X 1.0 X 16mm SHCS
6	2	35505	SCREW M6 X 1.0 X 30 SHCS
7	2	43489	BALL NYLON 1/8 DIA
8	1	45034	SCREW M6 X 1.0 X 12MM SSSDPPL
9	1	46902	LABEL WARNING HOT SURFACE GRAPHIC 1.13" TALL
10	1	48526	NUT LEADSCREW ACME 3/4-10 BRONZE LH
11	2	53365	SCREW M4 X 0.7 X 4 mm SSSFP
12	1	57214	BRG RETAINING NUT AXIAL FEED LEADSCREW
13	2	57320	RING O 1/16 X 13/16 ID X 15/16 OD
14	1	57793	BEARING BLOCK LEADSCREW
15	1	58133	HANDLE ADJUSTABLE M6 X 1 X 20MM
16	2	59003	SCREW M6 X 1.0 X 14MM SHCS
17	4	74658	SCREW M6 X 1 X 25MM SSSDP
18	1	79826	PLATE DOVE CIRCULAR
19	1	80309	CLAMP TOOL BIT 3/4 SQ
20	AR	80419	(NOT SHOWN) SHIM 1.8 ID X 3.2 OD .001 THICK
21	AR	80420	(NOT SHOWN) SHIM 1.8 ID X 3.2 OD .002 THICK
22	AR	80421	(NOT SHOWN) SHIM 1.8 ID X 3.2 OD .005 THICK
23	1	82224	GIB TOOLHEAD
24	1	82280	SCREW M20 X 2.5 X 25MM SSSDP
25	1	89209	BASE TOOL HOLDER ODF LONG
26	1	89211	LEADSCREW TOOL HOLDER LONG
27	1	89212	TOP SLIDE TOOL HOLDER LONG

FIGURE A-5. SLIDE TOOL HOLDER PARTS LIST (P/N 89210)

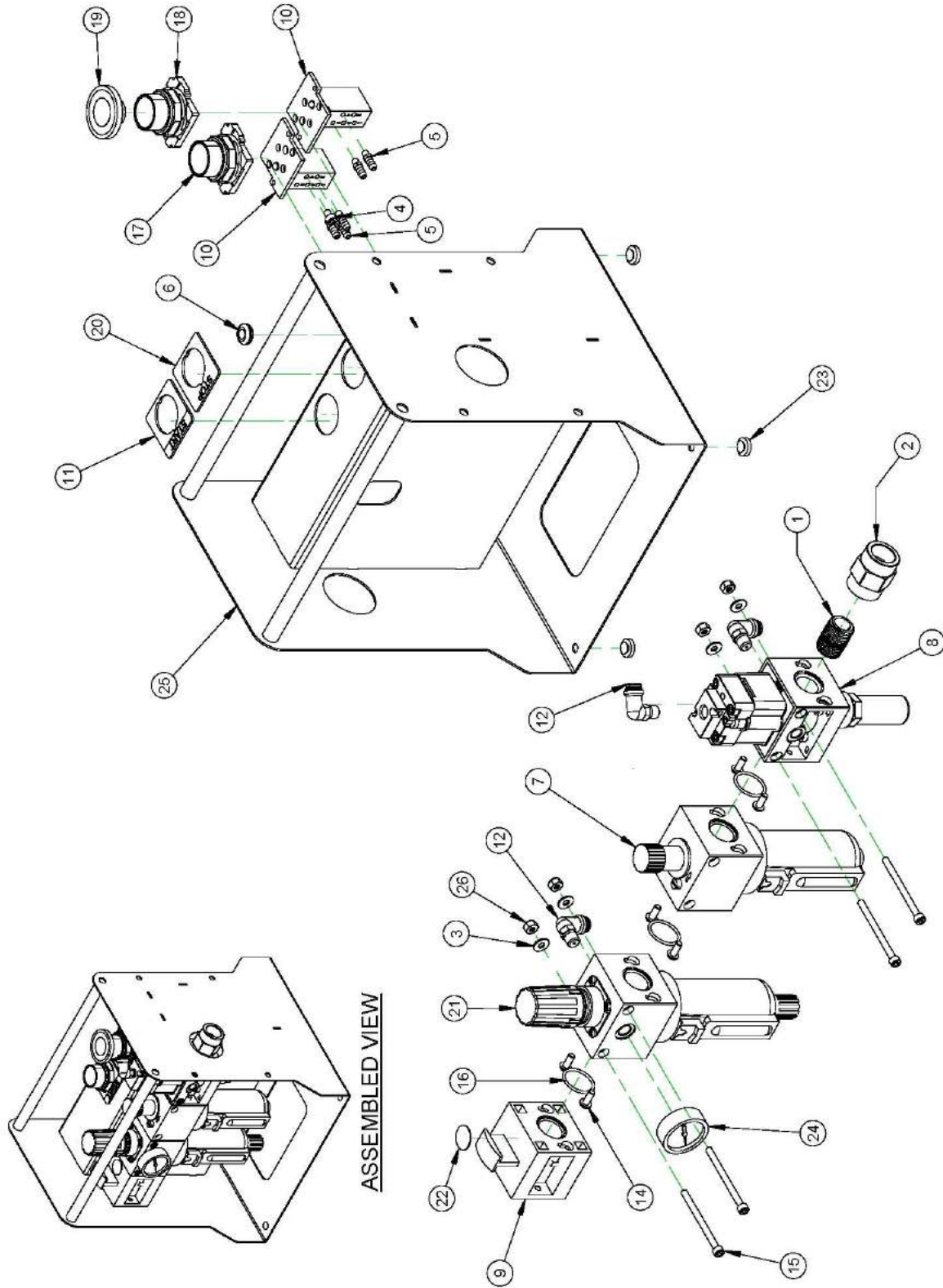
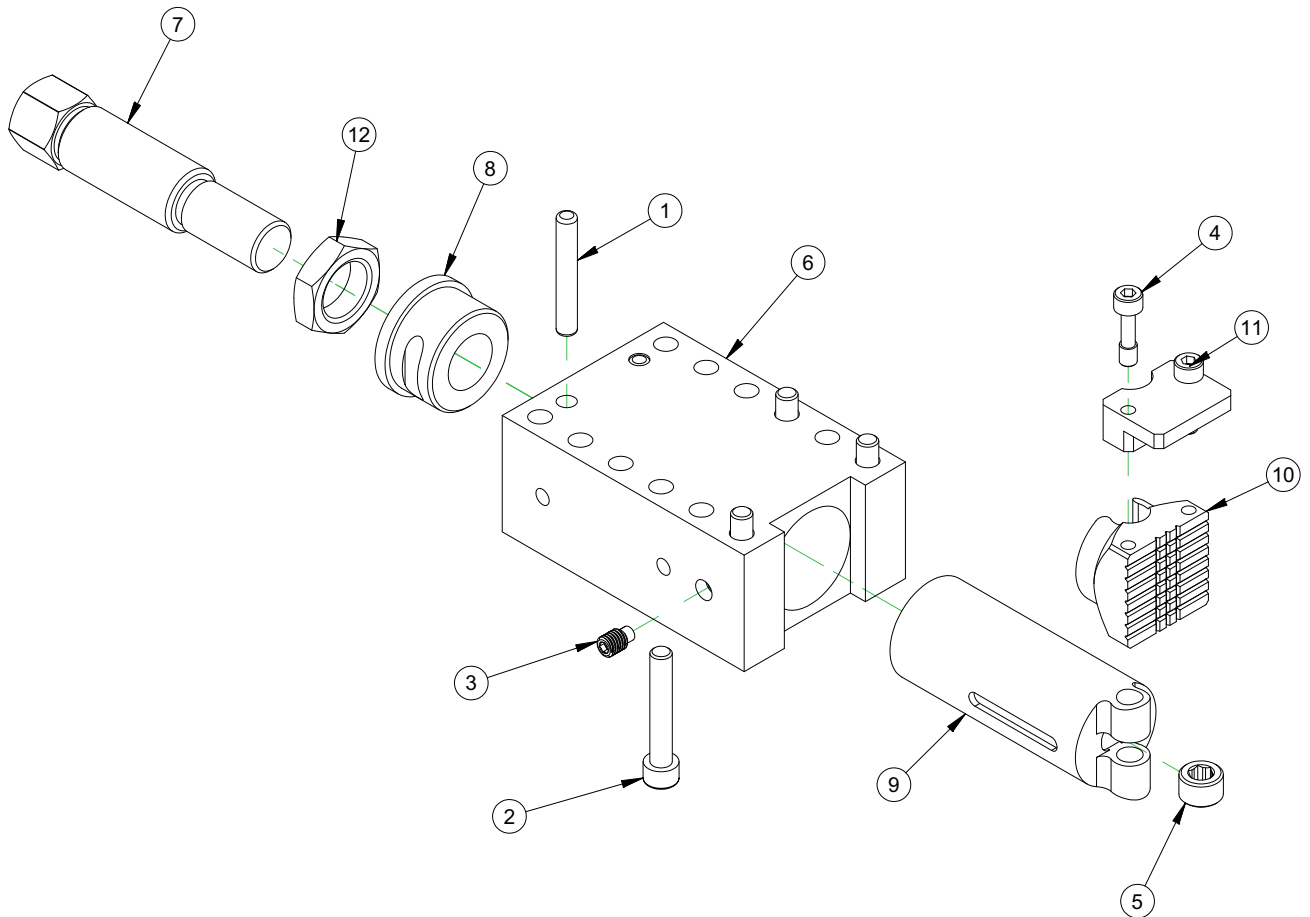

FIGURE A-6. PNEUMATIC CONDITIONING UNIT ASSEMBLY (P/N 83430)

PARTS LIST			
ITEM	QTY	P/N:	DESCRIPTION
1	1	10223	FTG NIPPLE CLOSE 1/2 NPTM X 1/2 NPTM 125 PSI 1-1/8 LONG
2	1	10319	FTG COUPLING 1/2 NPTF X 1/2 NPTF STEEL ZINC PLATED
3	4	11315	WASHER #10 FLTW BLACK OXIDE
4	1	14726	SCREW 10-32 X 1/4 SHCS
5	5	22235	FTG BARB #10-32 X 1/8 HOSE
6	1	40588	GROMMET 5/8 OD 5/16 ID
7	1	46768	LUBRICATOR AIR 1/2 NPTF 3.8OZ BOWL W/SIGHT
8	1	46769	VALVE EXHAUST QUICK PILOT 1/2NPTF MUFFLER
9	1	46777	VALVE SHUT OFF VS22 SERIES
10	2	46785	VALVE PUSHBUTTON 5 PORT PNEUMATIC
11	1	46797	LEGEND PLATE START 10250 SERIES
12	3	48648	FTG ELBOW 1/8 NPTM X 1/4 TUBE PRESTOLOK
13	28	48650	(NOT SHOWN) TUBING 1/4 OD POLYURETHANE
14	6	53617	SCREW M5 X 0.8 X 12MM BHCS BLACK FINISH
15	4	56357	SCREW 10-24 X 2.5 SHCS
16	3	59442	RING O 2mm X 23mm ID X 25mm OD
17	1	59458	PUSHBUTTON GREEN FLUSH
18	1	59459	PUSH BUTTON PUSH PULL MAINTAINED (M-M)
19	1	59462	PUSH BUTTON OPERATOR RED 1-5/8
20	1	59825	LEGEND PLATE STOP 10250SERIES YELLOW BACKGROUND
21	1	78054	FILTER/REGULATOR PARTICULATE 1/2NPTF METAL BOWL GLASS
22	1	81132	LABEL WARNING - INSERT SAFETY LOCK
23	4	83462	RUBBER BUMPER, 9/16 DIA X 1/8 TALL
24	1	83486	PRESSURE GAUGE, 0-160 PSI, 1/8 NPT CENTER BACK MOUNT
25	1	87223	STAND PCU
26	4	87533	NUT 10-24 STDNYLOC SS

FIGURE A-7. PNEUMATIC CONDITIONING UNIT ASSEMBLY (P/N 83430)



PARTS LIST			
ITEM	QTY	P/N:	DESCRIPTION
1	2	14297	PIN DOWEL 3/8 DIA X 2-1/2
2	4	45754	SCREW M10 x 1.5 x 60mm SHCS
3	1	48998	SCREW M10 X 1.5 X 16mm SSSHDP
4	2	74632	SCREW M8 X 1.25 X 30 OAL X 10 THD L STAINLESS
5	1	80430	SCREW MODIFIED M20 X 1.5 X 12.7MM HOLLOW LOCK
6	1	86881	HOUSING JACKING FOOT
7	1	86882	SCREW JACKING FOOT
8	1	86883	BUSHING THD 1-1/4-7
9	1	86884	RAM JACKING LEVELING
10	1	86885	JAW JACKING LEVELING
11	1	86886	SETUP FINGER
12	1	86908	NUT 1-1/4-7 JAMN 1/2 THICK

FIGURE A-8. JACKING FOOT LEVELING ASSEMBLY (P/N 86880)

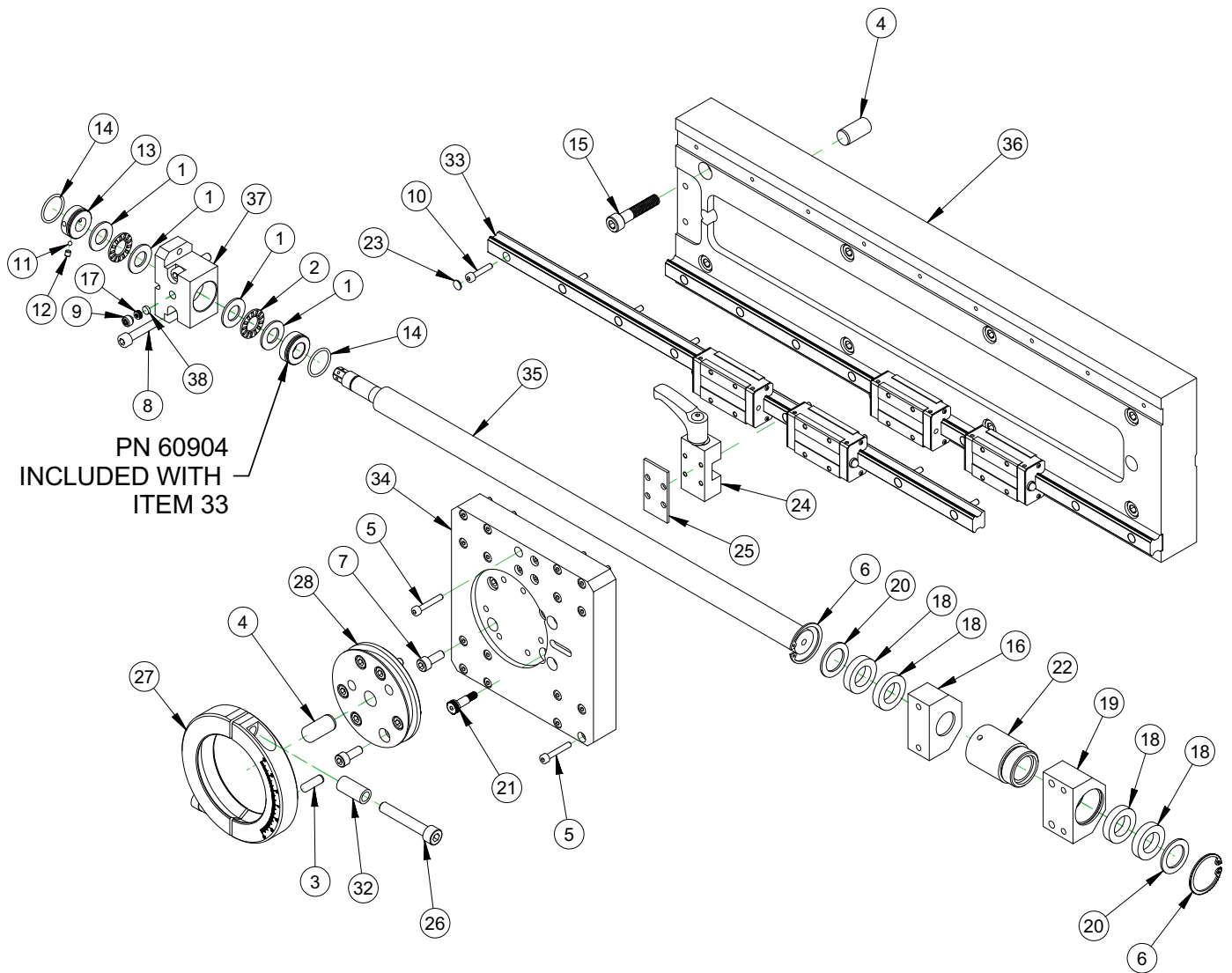
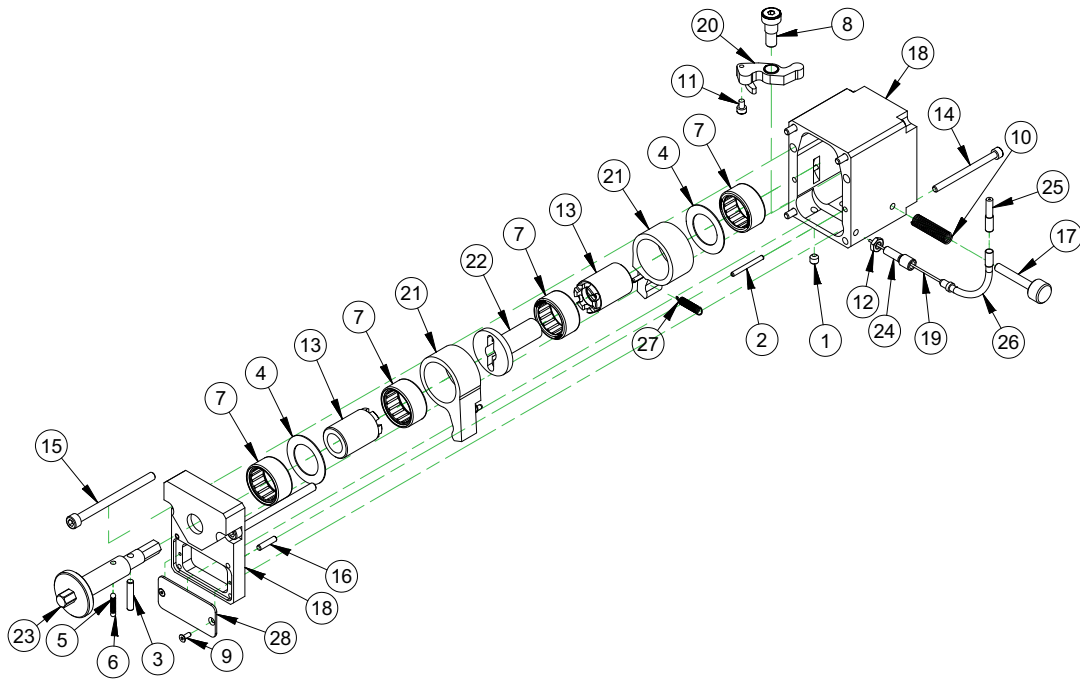

FIGURE A-9. RADIAL AXIS ASSEMBLY (P/N 86890)

PARTS LIST			
ITEM	QTY	P/N:	DESCRIPTION
1	4	10436	WASHER THRUST .500 ID X .937 OD X .060
2	2	10437	BRG THRUST .500 ID X .937 OD X .0781
3	1	11729	PIN DOWEL 1/4 DIA X 3/4
4	3	20398	PIN DOWEL 1/2 DIA X 1
5	20	22572	SCREW M4 X 0.7 X 25mm SHCS
6	2	33777	RING SNAP 1-3/16 ID (30MM)
7	10	35014	SCREW M6 X 1.0 X 16mm SHCS
8	2	35505	SCREW M6 X 1.0 X 30 SHCS
9	1	36087	SCREW M8 X 1.25 X 6MM SSSFP
10	18	38061	SCREW M4 X 0.7 X 20 SHCS
11	2	43489	BALL NYLON 1/8 DIA
12	2	53365	SCREW M4 X 0.7 X 4 mm SSSFP
13	1	57214	BRG RETAINING NUT AXIAL FEED LEADSCREW
14	2	57320	RING O 1/16 X 13/16 ID X 15/16 OD
15	8	61225	SCREW M8 X 1.25 X 40MM SHCS
16	1	62321	HOLDER FELT WIPER MILLING HEAD
17	6	62376	WASHER SPRING BELLEVILLE 1/8 ID X 1/4 OD X .013 THK
18	4	62379	SEAL FELT 16MM BALL SCREW 1.015 OD MILLING HEAD
19	1	62423	MOUNT BALL NUT MILLING HEAD
20	2	62903	WASHER SHIM .75 ID 1.125 OD .062 THICK STEEL
21	2	62909	SCREW 6MM DIA X 12MM X M5 X 0.8 SHLDCS
22	1	62960	BALL SCREW NUT 20MM X 5MM LEAD LEFT HAND 33 MM OD EICHENBERGER ROUND
23	18	68500	CAP RAIL 15MM METAL THK SHS
24	1	72636	ZIMMER BRAKE 15MM RAIL
25	1	72637	ZIMMER ADAPTER 15MM RAIL
26	2	72753	SCREW M8 X 1.25 X 50MM SHCS
27	1	79793	CLAMP COLLAR
28	1	79826	PLATE DOVE CIRCULAR
29	AR	80419	(NOT SHOWN) SHIM 1.8 ID X 3.2 OD .001 THICK
30	AR	80420	(NOT SHOWN) SHIM 1.8 ID X 3.2 OD .002 THICK
31	AR	80421	(NOT SHOWN) SHIM 1.8 ID X 3.2 OD .005 THICK
32	2	82226	COLLAR 8MM ID X 12MM OD X 25MM
33	2	86891	SLIDE RAIL THK SHS15 520MM LG PRELOADED METAL SCRAPERS 2 SHORT BLOCKS
34	1	86892	PLATE RADIAL SADDLE
35	1	86895	BALL SCREW 20MM DIA SF RADIAL AXIS
36	1	86896	PLATE RADIAL AXIS BASE
37	1	86898	BEARING BLOCK BALLSCREW
38	1	87033	PAD POLYURETHANE 1/4 DIA X .08 THICK

FIGURE A-10. RADIAL AXIS ASSEMBLY PARTS LIST (P/N 86890)



PARTS LIST

ITEM	QTY	P/N:	DESCRIPTION
1	1	10464	SCREW 1/4-20 X 1/4 SSSCP
2	2	11884	PIN DOWEL 1/8 DIA X 1-1/4
3	1	14284	PIN DOWEL 3/16 DIA X 1
4	2	15079	WASHER THRUST 1.000 ID X 1.562 OD X .030
5	1	19561	SPRING COMP .148 OD X .023 WIRE X .50 LONG STAINLESS
6	2	19562	BALL STEEL 5/32 DIA
7	4	25957	BRG ROLLER CLUTCH 1 X 1.312 X .625
8	1	29286	SCREW 3/8 X 3/8 X 5/16-18 SHLDCS
9	2	35876	SCREW M3 X .5 X 8MM FHSCS
10	1	36148	SPRING COMP .36 OD X .032 WIRE X 1.25 LONG
11	1	36152	SCREW M4 X 0.7 X 6mm SHCS
12	1	43019	NUT M6 X 1.0 JAMN ZINC PLATED
13	2	44721	DRIVE BUSHING
14	4	56357	SCREW 10-24 X 2.5 SHCS
15	2	59057	SCREW M6 X 1.0 X 80 mm SHCS CL12.9 ZINC COATED
16	2	60165	PIN DOWEL 5/32 DIA X 11/16
17	1	76599	SCREW M6 X 1.0 X 40MM KNURLED HEAD
18	1	86899	HOUSING FEEDBOX PULL CABLE
19	1	86905	CABLE BRAKE PULL 1.5MM
20	1	86909	PIVOT LINK PULL CABLE FEED
21	2	86973	CLUTCH ARM PULL CABLE FEED
22	1	86978	COUPLING FLANGED 3/8 INTERNAL HEX
23	1	86979	SHAFT PULL CABLE FEED BOX
24	1	87038	BOLT ADJUSTING M6 5MM BRAKE CABLE
25	A/R	87181	HOUSING 5MM DIA BRAKE CABLE
26	1	87198	BEND 90 DEG BRAKE CABLE
27	2	87528	SPRING EXT .18 OD X .023 WIRE X 1-1/4
28	1	87535	COVER FEEDBOX PULL CABLE

FIGURE A-11. PULL CABLE FEEDBOX ASSEMBLY (P/N 86900)

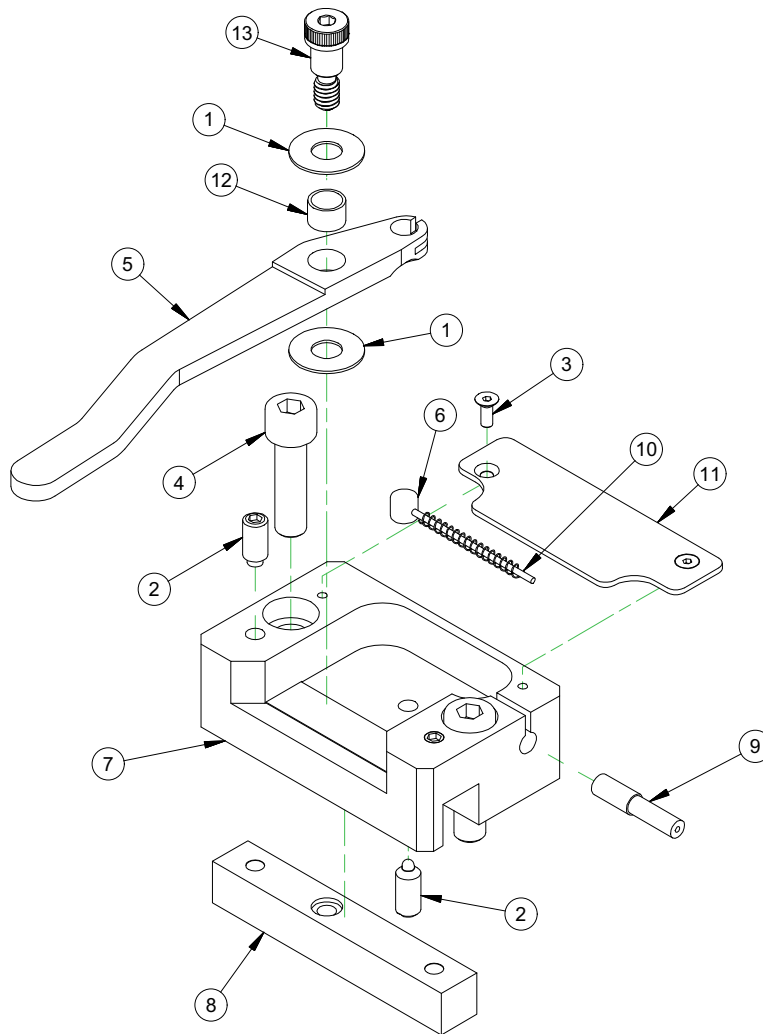

PARTS LIST				
ITEM	QTY	P/N:	DESCRIPTION	
1	2	10770	WASHER THRUST .75 OD X .312 ID X .03	
2	3	10848	PLUNGER DETENT SPRING STUBBY 1/4-20 X .531	
3	2	35876	SCREW M3 X .5 X 8MM FHSCS	
4	2	45530	SCREW M8 X 1.25 X 30mm SHCS	
5	1	86904	TRIP ARM CABLE FEED	
6	1	86905	CABLE BRAKE PULL 1.5MM X 1700MM	
7	1	86906	BLOCK FEED TRIP ACTUATOR	
8	1	86907	KEY PIVOT PULL CABLE FEED	
9	A/R	87181	HOUSING 5MM DIA BRAKE CABLE	
10	1	87529	SPRING COMP .136 OD X .010 WIRE X 1.34 LONG	
11	1	87610	COVER FEED ACTUATOR	
12	1	88151	BUSHING OILITE 1/4 ID X 3/8 OD X 1/4	
13	1	88152	SCREW 5/16 DIA X 3/8 X 1/4-20 SHLDCS	
14	A/R	89190	(NOT SHOWN) CONDUIT FLEXIBLE 3/8 SS	
15	2	89559	(NOT SHOWN) SLEEVE END PROTECTIVE 3/8 FLEXIBLE CONDUIT	

FIGURE A-12. FEED ACTUATOR IN THE PULL CABLE FEEDBOX ASSEMBLY (P/N 86900)

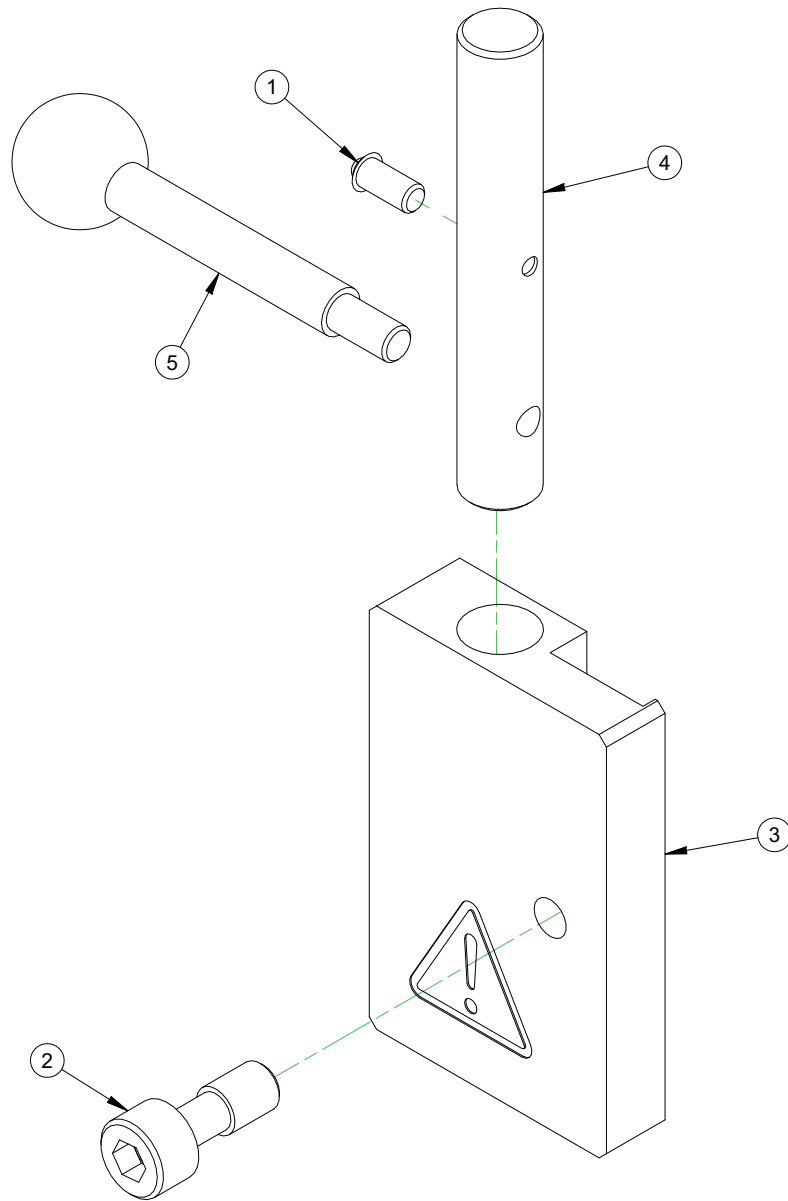

PARTS LIST			
ITEM	QTY	P/N:	DESCRIPTION
1	1	26828	PLUNGER BALL PUSHFIT
2	1	84563	SCREW M8 X 1.25 X 20MM SHCS CAPTIVE 10 THD STAINLESS
3	1	86902	BLOCK FEED TRIP
4	1	86903	ROD FEED TRIP
5	1	87023	LEVER M6 X 1.0 X 63MM ROUND RED HANDLE

FIGURE A-13. FEED TRIPPER ASSEMBLY (P/N 86910)

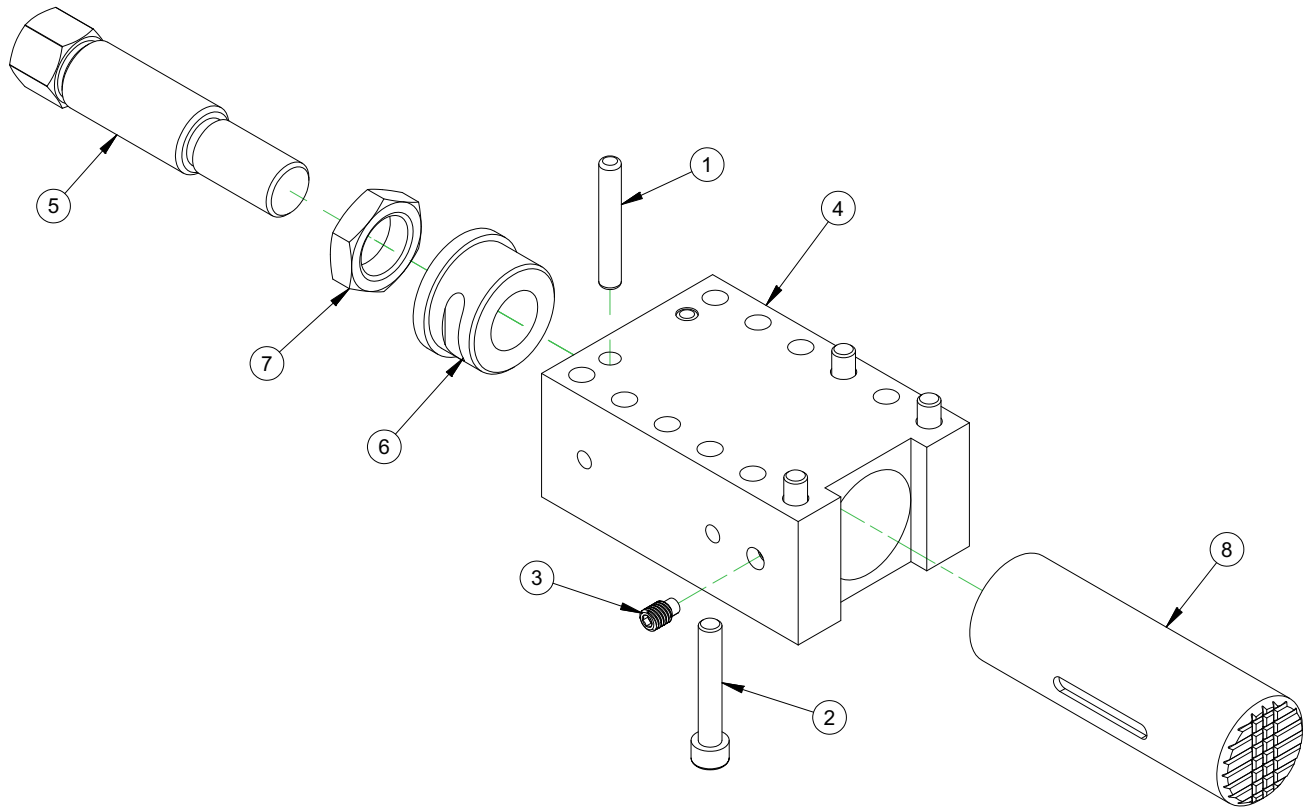

PARTS LIST			
ITEM	QTY	P/N:	DESCRIPTION
1	2	14297	PIN DOWEL 3/8 DIA X 2-1/2
2	4	45754	SCREW M10 x 1.5 x 60mm SHCS
3	1	48998	SCREW M10 X 1.5 X 16mm SSSHDP
4	1	86881	HOUSING JACKING FOOT
5	1	86882	SCREW JACKING FOOT
6	1	86883	BUSHING THD 1-1/4-7
7	1	86908	NUT 1-1/4-7 JAMN 1/2 THICK
8	1	86971	RAM JACKING NON-LEVELING

FIGURE A-14. NON-LEVELING JACKING FOOT ASSEMBLY (P/N 86970)

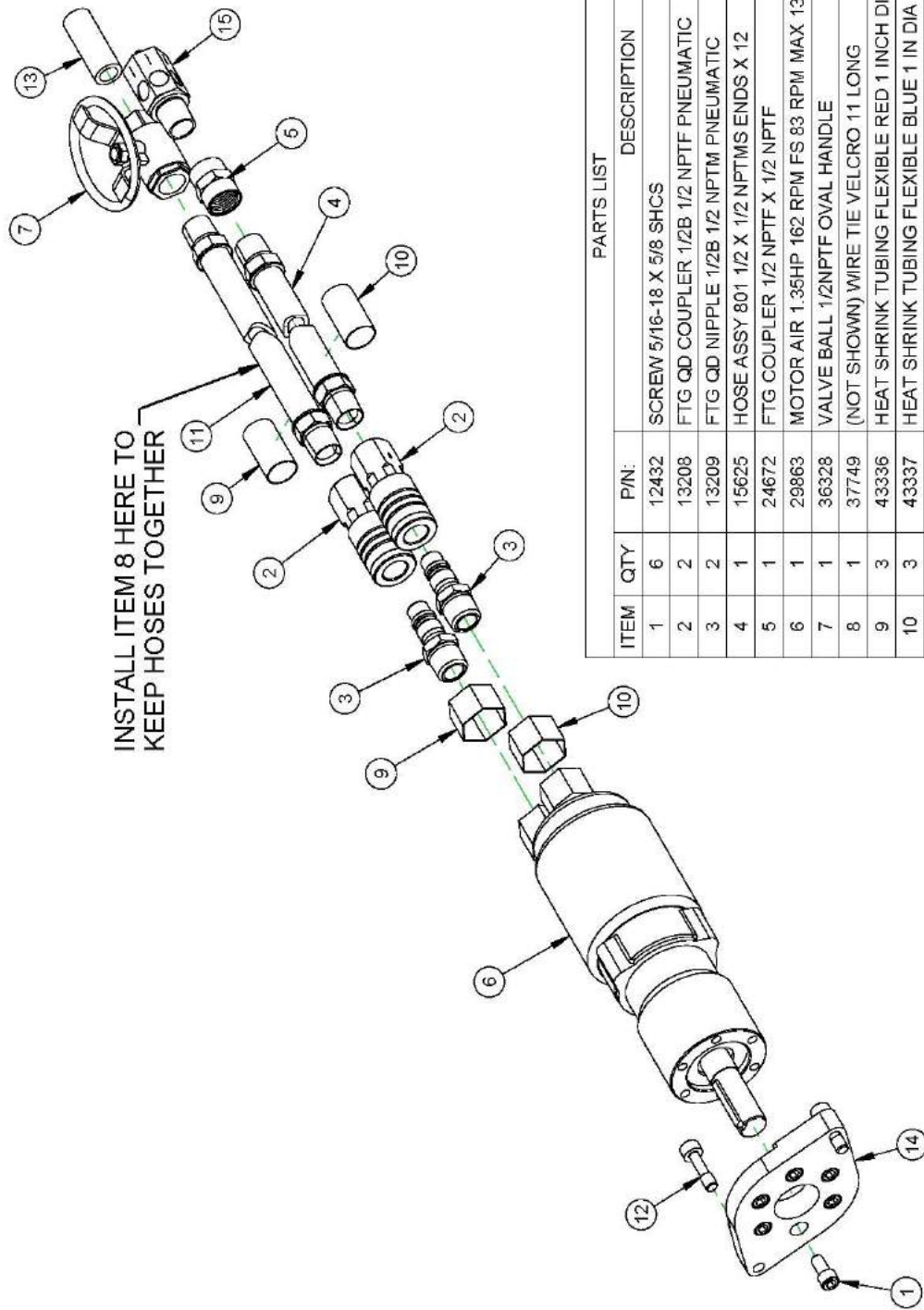

ITEM		QTY	P/N:	DESCRIPTION
1	6	12432	SCREW 5/16-18 X 5/8 SHCS	
2	2	13208	FTG QD COUPLER 1/2B 1/2 NPTF PNEUMATIC	
3	2	13209	FTG QD NIPPLE 1/2B 1/2 NPTM PNEUMATIC	
4	1	15625	HOSE ASSY 801 1/2 X 1/2 NPTMS ENDS X 12	
5	1	24672	FTG COUPLER 1/2 NPTF X 1/2 NPTF	
6	1	29863	MOTOR AIR 1.35HP 162 RPM FS 83 RPM MAX 134TQ REVERSE ROTATION	
7	1	36328	VALVE BALL 1/2NPTF OVAL HANDLE	
8	1	37749	(NOT SHOWN) WIRE TIE VELCRO 11 LONG	
9	3	43336	HEAT SHRINK TUBING FLEXIBLE RED 1 INCH DIA	
10	3	43337	HEAT SHRINK TUBING FLEXIBLE BLUE 1 IN DIA	
11	1	59376	HOSE ASSY 801 1/2 X 1/2 NPTMS ENDS X 180	
12	2	74632	SCREW M8 X 1.25 X 30 OAL X 10 THD L STAINLESS	
13	1	76030	FTG NIPPLE 1/2 NPTM X 2 INCH BRASS	
14	1	86893	PLATE AIR MOTOR MOUNT	
15	1	87263	FTG MUFFLER EXHAUST FLOW CONTROL 1/2 NPTM	

FIGURE A-15. DRIVE MOTOR ASSEMBLY (P/N 86989)

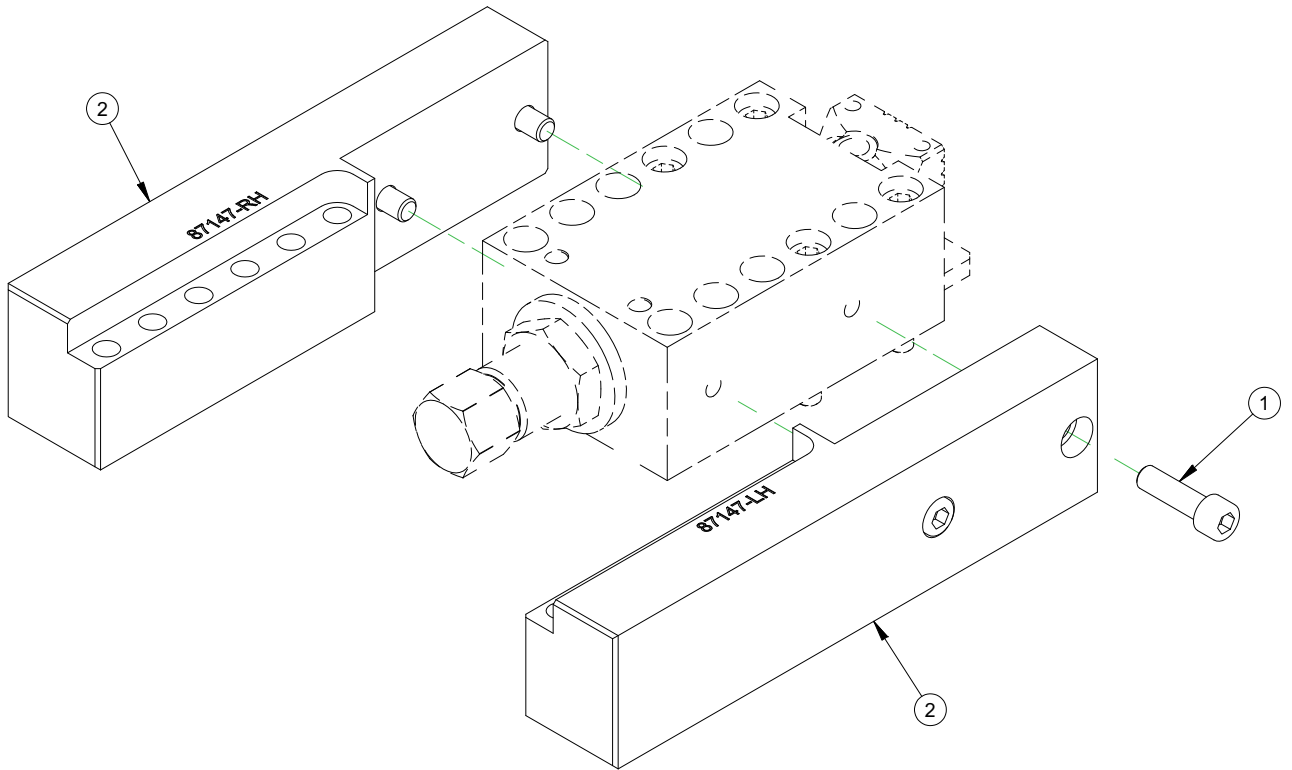

PARTS LIST			
ITEM	QTY	P/N:	DESCRIPTION
1	4	36079	SCREW M10 X 1.5 X 35mm SHCS
2	1	87147	BAR SF MOUNTING FOOT EXTENSION SET

FIGURE A-16. EXTENSION FOOT ASSEMBLY (P/N 87164)

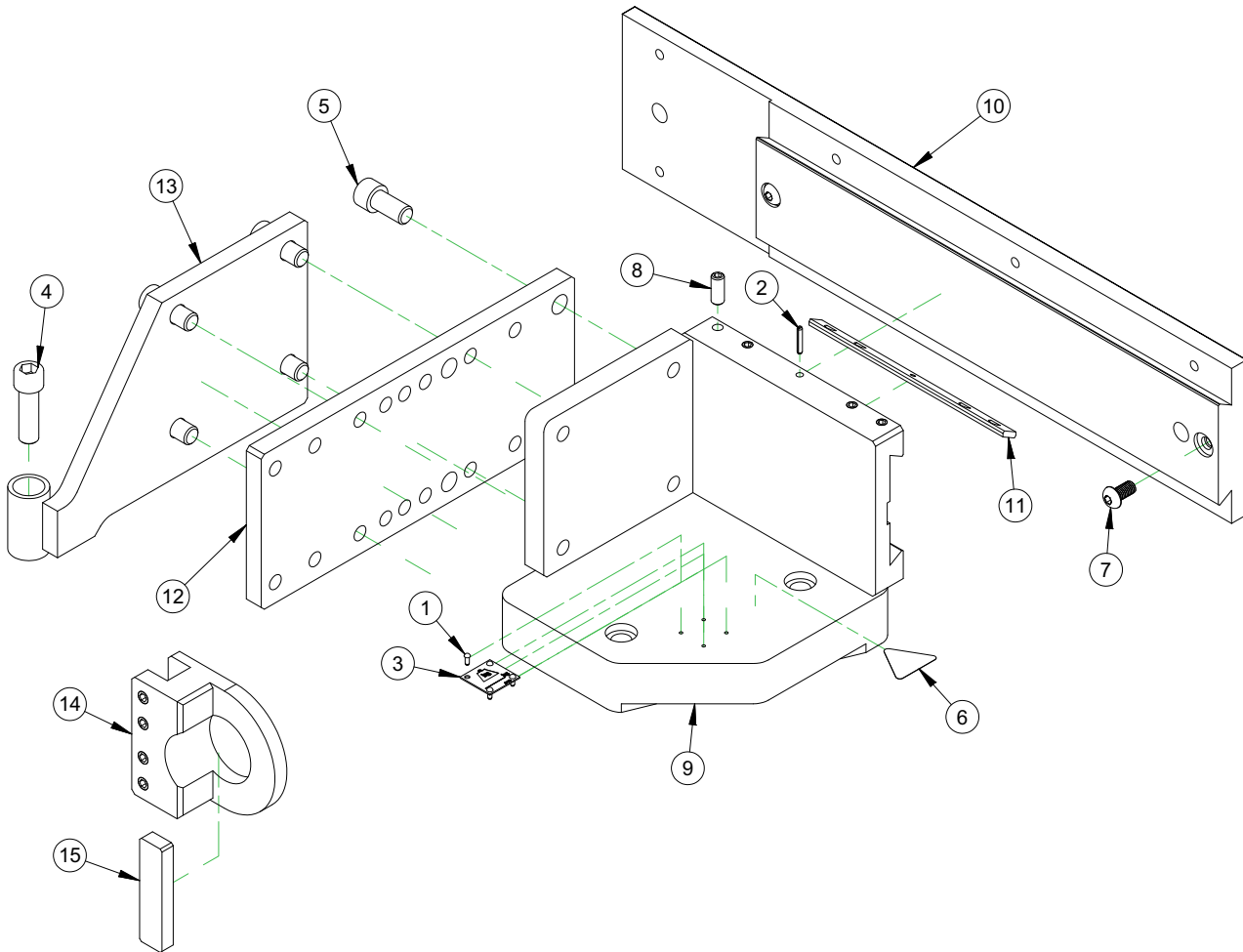

PARTS LIST

ITEM	QTY	P/N:	DESCRIPTION
1	4	10588	SCREW DRIVE #2 x 1/4 HOLE SIZE .089
2	1	10847	PIN ROLL 1/8 DIA X 3/4
3	1	29152	PLATE MASS CE
4	5	35215	SCREW M12 X 1.75 X 40mm SHCS
5	6	42094	SCREW M12 X 1.75 X 25mm SHCS
6	1	59042	LABEL WARNING - HAND CRUSH/MOVING PARTS
7	2	59827	SCREW M8 X 1.25 X 16MM BHSCS
8	4	83708	SCREW M8 X 1.25 X 20 SSSFP
9	1	87308	WELDMENT BACKFACING ANGLE MOUNT
10	1	87309	PLATE BACKFACING MOUNT
11	1	87416	GIB .435 X .156 X 6.5 0-1 4 SS W/ DOWEL
12	1	87797	PLATE BACKFACING BRACE-1
13	1	87798	PLATE BACKFACING BRACE-2
14	1	89203	HOLDER OFFSET TOOL
15	1	89223	BAR TOOL CLAMP

FIGURE A-17. BACKFACING ATTACHMENT ASSEMBLY (P/N 87310)

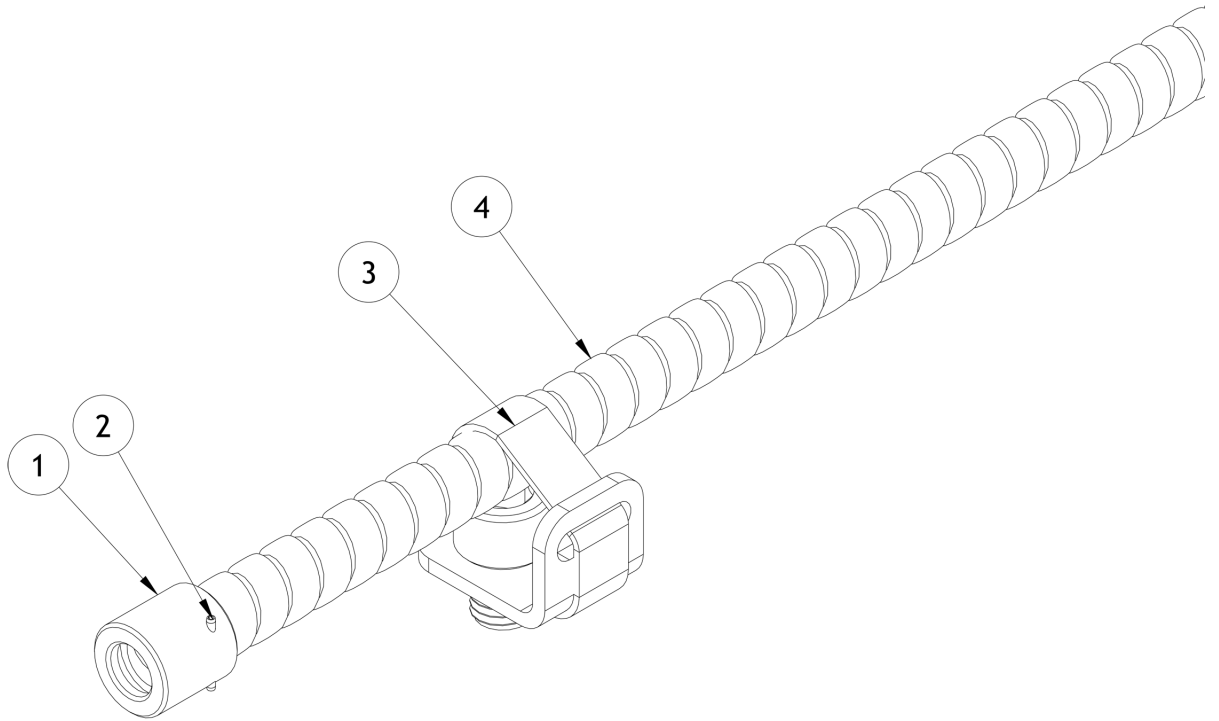

PARTS LIST			
ITEM	QTY	P/N:	DESCRIPTION
1	2	100253	END CAP CONDUIT 3/4
2	2	100252	PIN SPRING 1/16 X 5/8
3	2	37749	STRAP VELCRO 8" LONG
4	A/R	89190	FLEX CONDUIT SS 3/8

FIGURE A-18. CABLE PROTECTION COMPONENTS

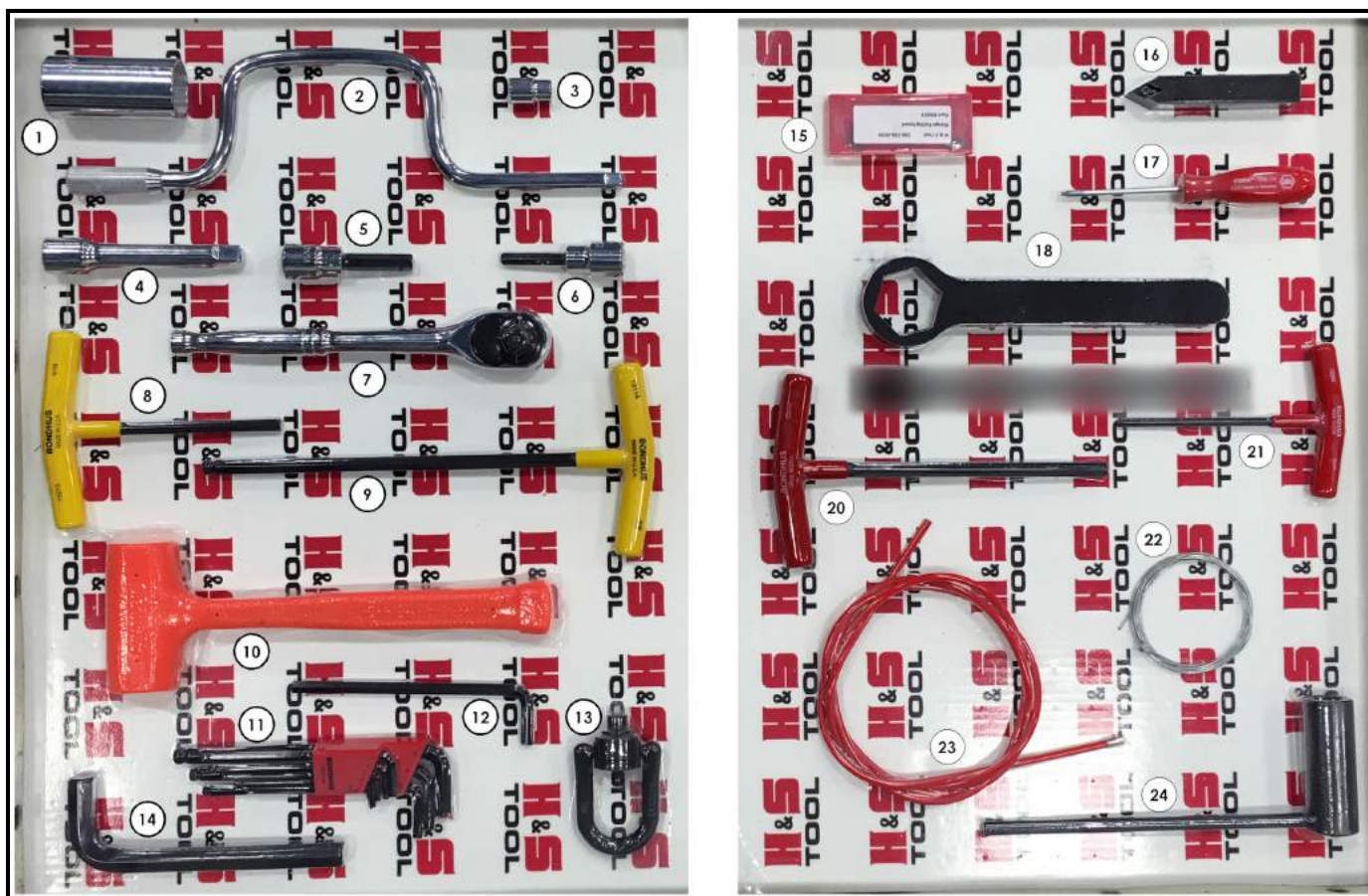

PARTS LIST

ITEM	QTY	P/N:	DESCRIPTION
1	1	86612	WRENCH SOCKET 1-1/4 X 1/2 DRIVE 12 POINT DEEP
2	1	13076	WRENCH SPEED HANDLE 3/8 DRIVE
3	1	19261	WRENCH SOCKET 3/8 6 POINT X 3/8 DRIVE
4	1	58354	EXTENSION DRIVE WRENCH 1/2 DRIVE X 5
5	1	46250	WRENCH HEX BIT SOCKET 10MM X 1/2
6	1	46251	WRENCH HEX BIT SOCKET 8MM X 1/2
7	1	14818	WRENCH RATCHET 1/2 DRIVE
8	1	40806	WRENCH HEX 5/16 X 6 T-HANDLE
9	1	55924	WRENCH HEX 3/8 X 12 T-HANDLE
10	1	35516	HAMMER DEAD BLOW 1-3/4 DIA HEAD (KB)
11	1	38678	WRENCH HEX SET 1.5-10MM BONDHUS BALL END (KB)
12	1	67461	WRENCH HEX 5/16 LONG ARM
13	2	41741	HOIST RING 3/8-16 X .56 1.3 ID OD 3.79 OAL 1000LBS SWIVEL
14	1	41060	WRENCH HEX 5/8 SHORT ARM
15	5	87266	INSERT CARBIDE 55 DEG DIAMOND IC8250
16	1	87268	HOLDER INSERT 55 DEGREE DIAMOND 3/4 SHANK NEUTRAL
17	1	36954	WRENCH TORX FT-15
18	1	87542	WRENCH BOX 1-5/8 X 1/2 THICK
20	1	87541	WRENCH HEX 10MM X 9 T-HANDLDE
21	1	35821	WRENCH HEX 6MM X 6 T-HANDLE
22	1	86905	CABLE BRAKE PULL 1.5MM X 1700MM
23	1	87181	HOUSING 5MM BRAKE CABLE
24	1	86988	WRENCH SOCKET 7/8 WITH HANDLE
25	1	86988A	ROUND STEEL ROD 3/8 (9 LONG)
26	1	89175	ADAPTER 3/4 SQ TO 1/2 SQ TOOL CLAMP

FIGURE A-19. TOOL KIT (P/N 78530)

APPENDIX B SDS

SDS list

LPS 1.....	57	Mobil Vactra Oil Heavy Medium	88
LPS 2.....	66	Moly Grade Anti-Seize.....	98
LPS All-Purpose Anti-Seize.....	75	Nook E-100	102
LPS ThermaPlex Bearing Grease	81	Nook PAG-1	109
		Unax AW 32	117

This page intentionally left blank



SAFETY DATA SHEET

1. Identification

Product identifier	LPS® 1 (Aerosol)
Other means of identification	
Part Number	00116
Recommended use	An industrial lubricant designed to displace moisture from mechanical and electrical equipment, provide light-duty lubrication and short-term rust prevention.
Recommended restrictions	None known.
Manufacturer/Importer/Supplier/Distributor information	
Manufacturer	
Manufacturer	
Company name	LPS Laboratories, a division of Illinois Tool Works, Inc.
Address	4647 Hugh Howell Rd. Tucker, GA 30084 (U.S.A.)
Country	(U.S.A.)
In Case of Emergency	Tel: +1 770-243-8800 1-800-424-9300 (inside U.S.) +001 703-527-3887 (outside U.S.)
Website	www.lpslabs.com
E-mail	sds@lpslabs.com

2. Hazard(s) identification

Physical hazards	Flammable aerosols	Category 1
	Gases under pressure	Compressed gas
Health hazards	Skin corrosion/irritation	Category 2
	Sensitization, skin	Category 1B
	Specific target organ toxicity, single exposure	Category 3 narcotic effects
Environmental hazards	Not classified.	
OSHA defined hazards	Not classified.	
Label elements		



Signal word	Danger
Hazard statement	Extremely flammable aerosol. Contains gas under pressure; may explode if heated. Causes skin irritation. May cause an allergic skin reaction. May cause drowsiness or dizziness.
Precautionary statement	
Prevention	Keep away from heat/sparks/open flames/hot surfaces. - No smoking. Do not spray on an open flame or other ignition source. Pressurized container: Do not pierce or burn, even after use. Avoid breathing gas. Wash thoroughly after handling. Use only outdoors or in a well-ventilated area. Contaminated work clothing must not be allowed out of the workplace. Wear protective gloves.
Response	If on skin: Wash with plenty of water. Take off contaminated clothing and wash before reuse. Specific treatment (see this label). If skin irritation or rash occurs: Get medical advice/attention. If inhaled: Remove person to fresh air and keep comfortable for breathing. Call a poison center/doctor if you feel unwell.
Storage	Store in a well-ventilated place. Keep container tightly closed. Store locked up. Protect from sunlight. Do not expose to temperatures exceeding 50°C/122°F.
Disposal	Dispose of contents/container in accordance with local/regional/national/international regulations.
Hazard(s) not otherwise classified (HNOC)	None known.
Supplemental information	None.

Material name: LPS® 1 (Aerosol)
802 Version #: 01 Issue date: 10-01-2014

SDS US
1 / 9

3. Composition/information on ingredients

Mixtures

Chemical name	Common name and synonyms	CAS number	%
Distillates Petroleum, Hydrotreated Light		64742-47-8	70 - 80
Distillates Petroleum Hydrotreated Med		64742-46-7	10 - 20
Carbon Dioxide		124-38-9	1 - 5
Sorbitan trioleate		26266-58-0	1 - 3
Calcium Sulfonate		61789-86-4	0.1 - 1

4. First-aid measures

Inhalation	Remove victim to fresh air and keep at rest in a position comfortable for breathing. Call a POISON CENTER or doctor/physician if you feel unwell.
Skin contact	Remove contaminated clothing immediately and wash skin with soap and water. In case of eczema or other skin disorders: Seek medical attention and take along these instructions. Wash contaminated clothing before reuse.
Eye contact	Immediately flush eyes with plenty of water for at least 15 minutes. Remove contact lenses, if present and easy to do. Continue rinsing. Get medical attention if irritation develops and persists.
Ingestion	In the unlikely event of swallowing contact a physician or poison control center. Rinse mouth. Do not induce vomiting without advice from poison control center. If vomiting occurs, keep head low so that stomach content doesn't get into the lungs.
Most important symptoms/effects, acute and delayed	May cause drowsiness and dizziness. Headache. Nausea, vomiting. Rash. Skin irritation. May cause redness and pain. May cause an allergic skin reaction. Dermatitis.
Indication of immediate medical attention and special treatment needed	Provide general supportive measures and treat symptomatically. Keep victim under observation. Symptoms may be delayed.
General information	Ensure that medical personnel are aware of the material(s) involved, and take precautions to protect themselves. Wash contaminated clothing before reuse.

5. Fire-fighting measures

Suitable extinguishing media	Alcohol resistant foam. Water spray. Water fog. Dry chemical powder. Dry chemicals. Carbon dioxide (CO2).
Unsuitable extinguishing media	Do not use water jet as an extinguisher, as this will spread the fire.
Specific hazards arising from the chemical	Contents under pressure. Pressurized container may explode when exposed to heat or flame. During fire, gases hazardous to health may be formed.
Special protective equipment and precautions for firefighters	Firefighters must use standard protective equipment including flame retardant coat, helmet with face shield, gloves, rubber boots, and in enclosed spaces, SCBA.
Fire fighting equipment/instructions	In case of fire: Stop leak if safe to do so. Move containers from fire area if you can do so without risk. Cool containers exposed to heat with water spray and remove container, if no risk is involved. Containers should be cooled with water to prevent vapor pressure build up. For massive fire in cargo area, use unmanned hose holder or monitor nozzles, if possible. If not, withdraw and let fire burn out.
Specific methods	Use standard firefighting procedures and consider the hazards of other involved materials. Move containers from fire area if you can do so without risk. Cool containers exposed to flames with water until well after the fire is out. In the event of fire and/or explosion do not breathe fumes.
General fire hazards	Extremely flammable aerosol. Contents under pressure. Pressurized container may explode when exposed to heat or flame.

6. Accidental release measures

Personal precautions, protective equipment and emergency procedures	Keep unnecessary personnel away. Keep people away from and upwind of spill/leak. Keep out of low areas. Many gases are heavier than air and will spread along ground and collect in low or confined areas (sewers, basements, tanks). Wear appropriate protective equipment and clothing during clean-up. Avoid breathing gas. Do not touch damaged containers or spilled material unless wearing appropriate protective clothing. Ventilate closed spaces before entering them. Local authorities should be advised if significant spillages cannot be contained. Use personal protection recommended in Section 8 of the SDS.
--	---

Methods and materials for containment and cleaning up

Refer to attached safety data sheets and/or instructions for use. Eliminate all ignition sources (no smoking, flares, sparks, or flames in immediate area). Keep combustibles (wood, paper, oil, etc.) away from spilled material. Stop leak if you can do so without risk. Move the cylinder to a safe and open area if the leak is irreparable. Use water spray to reduce vapors or divert vapor cloud drift. Isolate area until gas has dispersed. Dike far ahead of spill for later disposal. Scoop up used absorbent into drums or other appropriate container. Prevent entry into waterways, sewer, basements or confined areas. Following product recovery, flush area with water. For waste disposal, see section 13 of the SDS.

Environmental precautions

Avoid discharge into drains, water courses or onto the ground.

7. Handling and storage

Precautions for safe handling

Pressurized container: Do not pierce or burn, even after use. Do not use if spray button is missing or defective. Do not spray on a naked flame or any other incandescent material. Do not smoke while using or until sprayed surface is thoroughly dry. Do not cut, weld, solder, drill, grind, or expose containers to heat, flame, sparks, or other sources of ignition. Do not re-use empty containers. Avoid breathing gas. Avoid contact with eyes, skin, and clothing. Avoid prolonged exposure. Use only in well-ventilated areas. Wear appropriate personal protective equipment. Observe good industrial hygiene practices.

Conditions for safe storage, including any incompatibilities

Level 1 Aerosol.

Store locked up. Pressurized container. Protect from sunlight and do not expose to temperatures exceeding 50°C/122 °F. Do not puncture, incinerate or crush. Do not handle or store near an open flame, heat or other sources of ignition. Store in original tightly closed container. Store in a well-ventilated place. Keep out of the reach of children. Store away from incompatible materials (see Section 10 of the SDS).

8. Exposure controls/personal protection

Occupational exposure limits

U.S. - OSHA Components

Components	Type	Value	Form
Distillates Petroleum, Hydrotreated Light (CAS 64742-47-8)	PEL	5 mg/m3	Oil mist

US. OSHA Table Z-1 Limits for Air Contaminants (29 CFR 1910.1000) Components

Components	Type	Value
Carbon Dioxide (CAS 124-38-9)	PEL	9000 mg/m3 5000 ppm

ACGIH Components

Components	Type	Value	Form
Distillates Petroleum, Hydrotreated Light (CAS 64742-47-8)	TWA	5 mg/m3	Oil mist

US. ACGIH Threshold Limit Values Components

Components	Type	Value
Carbon Dioxide (CAS 124-38-9)	STEL	30000 ppm
	TWA	5000 ppm

US. NIOSH: Pocket Guide to Chemical Hazards Components

Components	Type	Value
Carbon Dioxide (CAS 124-38-9)	STEL	54000 mg/m3 30000 ppm
	TWA	9000 mg/m3 5000 ppm

Biological limit values

No biological exposure limits noted for the ingredient(s).

Appropriate engineering controls

Good general ventilation (typically 10 air changes per hour) should be used. Ventilation rates should be matched to conditions. If applicable, use process enclosures, local exhaust ventilation, or other engineering controls to maintain airborne levels below recommended exposure limits. If exposure limits have not been established, maintain airborne levels to an acceptable level.

Individual protection measures, such as personal protective equipment

Eye/face protection	Wear safety glasses with side shields (or goggles).
Skin protection	
Hand protection	Chemical resistant gloves are recommended.
Other	Avoid contact with the skin. Wear appropriate chemical resistant clothing.
Respiratory protection	When workers are facing concentrations above the exposure limit they must use appropriate certified respirators.
Thermal hazards	Not applicable.
General hygiene considerations	Always observe good personal hygiene measures, such as washing after handling the material and before eating, drinking, and/or smoking. Routinely wash work clothing and protective equipment to remove contaminants.

9. Physical and chemical properties

Appearance	Liquid.
Physical state	Gas.
Form	Aerosol.
Color	Amber.
Odor	Characteristic.
Odor threshold	Not available.
pH	Not applicable
Melting point/freezing point	< -58 °F (< -50 °C)
Initial boiling point and boiling range	415.4 °F (213 °C)
Flash point	174.2 °F (79.0 °C) Tag Closed Cup (dispensed liquid)
Evaporation rate	< 0.1 (BuAc = 1)
Flammability (solid, gas)	Flammable gas.
Upper/lower flammability or explosive limits	
Flammability limit - lower (%)	0.6 %
Flammability limit - upper (%)	7 %
Explosive limit - lower (%)	Not available.
Explosive limit - upper (%)	Not available.
Vapor pressure	< 0.05 mm Hg @ 20°C
Vapor density	> 1 (air = 1)
Relative density	0.79 - 0.81 @ 20°C
Solubility(ies)	
Solubility (water)	Not soluble
Partition coefficient (n-octanol/water)	< 1
Auto-ignition temperature	> 442.4 °F (> 228 °C)
Decomposition temperature	Not established
Viscosity	< 3.8 cSt @ 25°C
Other information	
Heat of combustion	Not established
Percent volatile	95 - 96 %
VOC (Weight %)	0.4 % per US State & Federal Consumer Product Regulations

10. Stability and reactivity

Reactivity	The product is stable and non-reactive under normal conditions of use, storage and transport.
Chemical stability	Material is stable under normal conditions.

Possibility of hazardous reactions	Hazardous polymerization does not occur.
Conditions to avoid	Avoid heat, sparks, open flames and other ignition sources. Avoid temperatures exceeding the flash point. Contact with incompatible materials.
Incompatible materials	Oxidizing agents.
Hazardous decomposition products	Carbon oxides.

11. Toxicological information

Information on likely routes of exposure

Inhalation	Vapors have a narcotic effect and may cause headache, fatigue, dizziness and nausea.
Skin contact	Causes skin irritation. May cause an allergic skin reaction.
Eye contact	Direct contact with eyes may cause temporary irritation.
Ingestion	May be fatal if swallowed and enters airways.

Symptoms related to the physical, chemical and toxicological characteristics
Symptoms may include stinging, tearing, redness, swelling, and blurred vision. Skin irritation. Exposure may cause temporary irritation, redness, or discomfort. Defatting of the skin. Rash. Vapors have a narcotic effect and may cause headache, fatigue, dizziness and nausea. Decrease in motor functions. Behavioral changes.

Information on toxicological effects

Acute toxicity Narcotic effects. May cause an allergic skin reaction.

Components	Species	Test Results
Calcium Sulfonate (CAS 61789-86-4)		
Acute		
<i>Dermal</i>		
LD50	Rabbit	> 2000 mg/kg, 24 Hours
	Rat	> 2000 mg/kg, 24 Hours
<i>Inhalation</i>		
LC50	Rat	> 1.9 mg/l, 4 Hours
<i>Oral</i>		
LD50	Rat	10000 - 20000 mg/kg
Distillates Petroleum Hydrotreated Med (CAS 64742-46-7)		
Acute		
<i>Dermal</i>		
LD50	Rabbit	> 2000 mg/kg, 24 Hours
<i>Inhalation</i>		
LC50	Rat	7640 mg/m3, 4 Hours 1.72 mg/l, 4 Hours
Distillates Petroleum, Hydroteated Light (CAS 64742-47-8)		
Acute		
<i>Dermal</i>		
LD50	Rabbit	> 2000 mg/kg > 2000 mg/kg, 24 Hours
<i>Inhalation</i>		
LC50	Cat	> 6.4 mg/l, 6 Hours
	Rat	> 7.5 mg/l, 6 Hours > 4.3 mg/l, 4 Hours > 0.1 mg/l, 8 Hours
<i>Oral</i>		
LD50	Rat	> 5000 mg/kg
Skin corrosion/irritation	Causes skin irritation.	
Serious eye damage/eye irritation	Direct contact with eyes may cause temporary irritation.	

Respiratory or skin sensitization

Respiratory sensitization Not a respiratory sensitizer.

Skin sensitization May cause an allergic skin reaction.

Germ cell mutagenicity No data available to indicate product or any components present at greater than 0.1% are mutagenic or genotoxic.

Carcinogenicity This product is not considered to be a carcinogen by IARC, ACGIH, NTP, or OSHA.

OSHA Specifically Regulated Substances (29 CFR 1910.1001-1050)

Not listed.

Reproductive toxicity This product is not expected to cause reproductive or developmental effects.

Specific target organ toxicity - single exposure Narcotic effects.

Specific target organ toxicity - repeated exposure Based on available data, the classification criteria are not met.

Aspiration hazard Not likely, due to the form of the product.

Chronic effects Prolonged inhalation may be harmful.

12. Ecological information

Ecotoxicity Harmful to aquatic life with long lasting effects.

Components	Species	Test Results
Distillates Petroleum, Hydrotreated Light (CAS 64742-47-8)		
Aquatic		
Fish	LC50 Rainbow trout, donaldson trout (Oncorhynchus mykiss)	2.9 mg/l, 96 hours

Persistence and degradability Not inherently biodegradable.

Bioaccumulative potential Not available.

Partition coefficient n-octanol / water (log Kow)

LPS® 1 (Aerosol) < 1

Mobility in soil No data available.

Other adverse effects None known.

13. Disposal considerations

Disposal instructions Consult authorities before disposal. Contents under pressure. Do not puncture, incinerate or crush. Dispose of contents/container in accordance with local/regional/national/international regulations.

Local disposal regulations Dispose in accordance with all applicable regulations.

Hazardous waste code D003: Waste Reactive material

Waste from residues / unused products Dispose of in accordance with local regulations. Empty containers or liners may retain some product residues. This material and its container must be disposed of in a safe manner (see: Disposal instructions).

Contaminated packaging Empty containers should be taken to an approved waste handling site for recycling or disposal. Since emptied containers may retain product residue, follow label warnings even after container is emptied. Do not re-use empty containers.

14. Transport information

DOT

UN number UN1950

UN proper shipping name Aerosols, flammable

Transport hazard class(es)

Class 2.1

Subsidiary risk -

Label(s) 2.1

Packing group Not applicable.

Environmental hazards

Marine pollutant No

Special precautions for user Read safety instructions, SDS and emergency procedures before handling.

Special provisions N82

Packaging exceptions 306

Packaging non bulk None
 Packaging bulk None

IATA

UN number UN1950
 UN proper shipping name Aerosols, flammable
 Transport hazard class(es)
 Class 2.1
 Subsidiary risk -
 Packing group Not applicable.
 Environmental hazards No
 ERG Code 10L
 Special precautions for user Read safety instructions, SDS and emergency procedures before handling.
 Other information
 Passenger and cargo aircraft Allowed.
 Cargo aircraft only Allowed.

IMDG

UN number UN1950
 UN proper shipping name AEROSOLS, Flammable
 Transport hazard class(es)
 Class 2.1
 Subsidiary risk -
 Label(s) 2.1
 Packing group Not applicable.
 Environmental hazards
 Marine pollutant No
 EmS F-D, S-U
 Special precautions for user Read safety instructions, SDS and emergency procedures before handling.

Transport in bulk according to Annex II of MARPOL 73/78 and the IBC Code This substance/mixture is not intended to be transported in bulk.

DOT**IATA; IMDG****15. Regulatory information**

US federal regulations This product is a "Hazardous Chemical" as defined by the OSHA Hazard Communication Standard, 29 CFR 1910.1200.
 All components are on the U.S. EPA TSCA Inventory List.

TSCA Section 12(b) Export Notification (40 CFR 707, Subpt. D)

Not regulated.

CERCLA Hazardous Substance List (40 CFR 302.4)

Not listed.

SARA 304 Emergency release notification

Not regulated.

OSHA Specifically Regulated Substances (29 CFR 1910.1001-1050)

Not listed.

Superfund Amendments and Reauthorization Act of 1986 (SARA)

Hazard categories
Immediate Hazard - Yes
Delayed Hazard - No
Fire Hazard - Yes
Pressure Hazard - Yes
Reactivity Hazard - No

SARA 302 Extremely hazardous substance

Not listed.

SARA 311/312 Hazardous chemical Yes

SARA 313 (TRI reporting)

Not regulated.

Other federal regulations**Clean Air Act (CAA) Section 112 Hazardous Air Pollutants (HAPs) List**

Not regulated.

Clean Air Act (CAA) Section 112(r) Accidental Release Prevention (40 CFR 68.130)

Not regulated.

Safe Drinking Water Act (SDWA) Not regulated.

US state regulations**US. California Controlled Substances. CA Department of Justice (California Health and Safety Code Section 11100)**

Not listed.

US. Massachusetts RTK - Substance List

Carbon Dioxide (CAS 124-38-9)

US. New Jersey Worker and Community Right-to-Know Act

Carbon Dioxide (CAS 124-38-9)

US. Pennsylvania Worker and Community Right-to-Know Law

Carbon Dioxide (CAS 124-38-9)

US. Rhode Island RTK

Not regulated.

US. California Proposition 65

California Safe Drinking Water and Toxic Enforcement Act of 1986 (Proposition 65): This material is not known to contain any chemicals currently listed as carcinogens or reproductive toxins.

International Inventories

Country(s) or region	Inventory name	On inventory (yes/no)*
Australia	Australian Inventory of Chemical Substances (AICS)	Yes
Canada	Domestic Substances List (DSL)	Yes
Canada	Non-Domestic Substances List (NDSL)	No
China	Inventory of Existing Chemical Substances in China (IECSC)	No
Europe	European Inventory of Existing Commercial Chemical Substances (EINECS)	Yes
Europe	European List of Notified Chemical Substances (ELINCS)	No
Japan	Inventory of Existing and New Chemical Substances (ENCS)	No
Korea	Existing Chemicals List (ECL)	Yes
New Zealand	New Zealand Inventory	No
Philippines	Philippine Inventory of Chemicals and Chemical Substances (PICCS)	Yes

Country(s) or region	Inventory name	On inventory (yes/no)*
United States & Puerto Rico	Toxic Substances Control Act (TSCA) Inventory	Yes

*A "Yes" indicates that all components of this product comply with the inventory requirements administered by the governing country(s)
A "No" indicates that one or more components of the product are not listed or exempt from listing on the inventory administered by the governing country(s).

16. Other information, including date of preparation or last revision

Issue date	10-01-2014
Version #	01
Disclaimer	LPS Laboratories cannot anticipate all conditions under which this information and its product, or the products of other manufacturers in combination with its product, may be used. It is the user's responsibility to ensure safe conditions for handling, storage and disposal of the product, and to assume liability for loss, injury, damage or expense due to improper use. The information provided in this Safety Data Sheet is correct to the best of our knowledge, information and belief at the date of its publication. The information given is designed only as a guidance for safe handling, use, processing, storage, transportation, disposal and release and is not to be considered a warranty or quality specification. The information relates only to the specific material designated and may not be valid for such material used in combination with any other materials or in any process, unless specified in the text.



SAFETY DATA SHEET

1. Identification

Product identifier	LPS® 2 (Aerosol)
Other means of identification	
Part Number	00216
Recommended use	An industrial lubricant designed to displace moisture from equipment, provide heavy-duty lubrication and rust prevention.
Recommended restrictions	None known.
Manufacturer/Importer/Supplier/Distributor information	
Manufacturer	
Manufacturer	
Company name	LPS Laboratories, a division of Illinois Tool Works, Inc.
Address	4647 Hugh Howell Rd. Tucker, GA 30084 (U.S.A.)
Country	(U.S.A.)
In Case of Emergency	Tel: +1 770-243-8800 1-800-424-9300 (inside U.S.) +001 703-527-3887 (outside U.S.)
Website	www.lpslabs.com
E-mail	sds@lpslabs.com

2. Hazard(s) identification

Physical hazards	Flammable aerosols	Category 1
	Gases under pressure	Compressed gas
Health hazards	Skin corrosion/irritation	Category 2
	Serious eye damage/eye irritation	Category 2A
	Specific target organ toxicity, single exposure	Category 3 narcotic effects
Environmental hazards	Not classified.	
OSHA defined hazards	Not classified.	
Label elements		



Signal word	Danger
Hazard statement	Extremely flammable aerosol. Contains gas under pressure; may explode if heated. Causes skin irritation. Causes serious eye irritation. May cause drowsiness or dizziness.
Precautionary statement	
Prevention	Keep away from heat/sparks/open flames/hot surfaces. - No smoking. Do not spray on an open flame or other ignition source. Pressurized container: Do not pierce or burn, even after use. Avoid breathing gas. Wash thoroughly after handling. Use only outdoors or in a well-ventilated area. Wear protective gloves. Wear eye/face protection.
Response	If on skin: Wash with plenty of water. If inhaled: Remove person to fresh air and keep comfortable for breathing. If in eyes: Rinse cautiously with water for several minutes. Remove contact lenses, if present and easy to do. Continue rinsing. Call a poison center/doctor if you feel unwell. Specific treatment (see this label). If skin irritation occurs: Get medical advice/attention. If eye irritation persists: Get medical advice/attention. Take off contaminated clothing and wash before reuse.
Storage	Store in a well-ventilated place. Keep container tightly closed. Store locked up. Protect from sunlight. Do not expose to temperatures exceeding 50°C/122°F.
Disposal	Dispose of contents/container in accordance with local/regional/national/international regulations.
Hazard(s) not otherwise classified (HNOC)	None known.

Supplemental information None.

3. Composition/information on ingredients

Mixtures

Chemical name	Common name and synonyms	CAS number	%
Distillates Petroleum, Hydrotreated Light		64742-47-8	70 - 80
Petroleum Oil		64742-52-5	10 - 20
Carbon Dioxide		124-38-9	1 - 5

4. First-aid measures

Inhalation	Remove victim to fresh air and keep at rest in a position comfortable for breathing. For breathing difficulties, oxygen may be necessary. Call a physician if symptoms develop or persist.
Skin contact	Wash off with soap and water. Get medical attention if irritation develops and persists.
Eye contact	Immediately flush eyes with plenty of water for at least 15 minutes. Remove contact lenses, if present and easy to do. Continue rinsing. Get medical attention if irritation develops and persists.
Ingestion	Call a physician or poison control center immediately. Only induce vomiting at the instruction of medical personnel. Never give anything by mouth to an unconscious person. If vomiting occurs, keep head low so that stomach content doesn't get into the lungs.
Most important symptoms/effects, acute and delayed	Dermatitis. Rash. Symptoms of overexposure may be headache, dizziness, tiredness, nausea and vomiting. Skin irritation. May cause redness and pain.
Indication of immediate medical attention and special treatment needed	Provide general supportive measures and treat symptomatically.
General information	Ensure that medical personnel are aware of the material(s) involved, and take precautions to protect themselves. Call a POISON CENTER or doctor/physician if you feel unwell.

5. Fire-fighting measures

Suitable extinguishing media	Powder. Alcohol resistant foam. Water. Water spray. Dry chemicals. Carbon dioxide (CO2).
Unsuitable extinguishing media	Do not use water jet as an extinguisher, as this will spread the fire.
Specific hazards arising from the chemical	Contents under pressure. Pressurized container may explode when exposed to heat or flame.
Special protective equipment and precautions for firefighters	Firefighters must use standard protective equipment including flame retardant coat, helmet with face shield, gloves, rubber boots, and in enclosed spaces, SCBA.
Fire fighting equipment/instructions	In case of fire: Stop leak if safe to do so. Move containers from fire area if you can do so without risk. Cool containers exposed to heat with water spray and remove container, if no risk is involved. Containers should be cooled with water to prevent vapor pressure build up. For massive fire in cargo area, use unmanned hose holder or monitor nozzles, if possible. If not, withdraw and let fire burn out.
Specific methods	Use standard firefighting procedures and consider the hazards of other involved materials. Move containers from fire area if you can do so without risk. Cool containers exposed to flames with water until well after the fire is out. In the event of fire and/or explosion do not breathe fumes.
General fire hazards	Extremely flammable aerosol.

6. Accidental release measures

Personal precautions, protective equipment and emergency procedures	Keep unnecessary personnel away. Keep people away from and upwind of spill/leak. Keep out of low areas. Wear appropriate protective equipment and clothing during clean-up. Do not touch damaged containers or spilled material unless wearing appropriate protective clothing. Ventilate closed spaces before entering them. Local authorities should be advised if significant spillages cannot be contained. Use personal protection recommended in Section 8 of the SDS.
Methods and materials for containment and cleaning up	Refer to attached safety data sheets and/or instructions for use. Eliminate all ignition sources (no smoking, flares, sparks, or flames in immediate area). Keep combustibles (wood, paper, oil, etc.) away from spilled material. Stop leak if you can do so without risk. Move the cylinder to a safe and open area if the leak is irreparable. Isolate area until gas has dispersed. Use water spray to reduce vapors or divert vapor cloud drift. Scoop up used absorbent into drums or other appropriate container. Prevent entry into waterways, sewer, basements or confined areas. Following product recovery, flush area with water. For waste disposal, see section 13 of the SDS.
Environmental precautions	Avoid discharge into drains, water courses or onto the ground.

Material name: LPS® 2 (Aerosol)
729 Version #: 01 Issue date: 09-22-2014

SDS US
2 / 9

7. Handling and storage

Precautions for safe handling

Pressurized container: Do not pierce or burn, even after use. Do not use if spray button is missing or defective. Do not spray on a naked flame or any other incandescent material. Do not smoke while using or until sprayed surface is thoroughly dry. Do not cut, weld, solder, drill, grind, or expose containers to heat, flame, sparks, or other sources of ignition. All equipment used when handling the product must be grounded. Do not re-use empty containers. Avoid prolonged or repeated contact with skin. Avoid prolonged exposure. Use only in well-ventilated areas. Wear appropriate personal protective equipment. Wash hands thoroughly after handling. Observe good industrial hygiene practices.

Conditions for safe storage, including any incompatibilities

Level 3 Aerosol.

Store locked up. Pressurized container. Protect from sunlight and do not expose to temperatures exceeding 50°C/122 °F. Do not puncture, incinerate or crush. Do not handle or store near an open flame, heat or other sources of ignition. This material can accumulate static charge which may cause spark and become an ignition source. Prevent electrostatic charge build-up by using common bonding and grounding techniques. Store in original tightly closed container. Store in a well-ventilated place. Store away from incompatible materials (see Section 10 of the SDS). Keep out of the reach of children.

8. Exposure controls/personal protection

Occupational exposure limits

U.S. - OSHA Components

Components	Type	Value	Form
Distillates Petroleum, Hydrotreated Light (CAS 64742-47-8)	PEL	5 mg/m3	Oil mist
Petroleum Oil (CAS 64742-52-5)	PEL	5 mg/m3	Oil mist

US. OSHA Table Z-1 Limits for Air Contaminants (29 CFR 1910.1000)

Components	Type	Value
Carbon Dioxide (CAS 124-38-9)	PEL	9000 mg/m3 5000 ppm

ACGIH

Components	Type	Value	Form
Distillates Petroleum, Hydrotreated Light (CAS 64742-47-8)	TWA	5 mg/m3	Oil mist
Petroleum Oil (CAS 64742-52-5)	TWA	5 mg/m3	Oil mist

US. ACGIH Threshold Limit Values

Components	Type	Value
Carbon Dioxide (CAS 124-38-9)	STEL	30000 ppm
	TWA	5000 ppm

US. NIOSH: Pocket Guide to Chemical Hazards

Components	Type	Value
Carbon Dioxide (CAS 124-38-9)	STEL	54000 mg/m3
		30000 ppm
	TWA	9000 mg/m3 5000 ppm

Biological limit values

No biological exposure limits noted for the ingredient(s).

Appropriate engineering controls

Good general ventilation (typically 10 air changes per hour) should be used. Ventilation rates should be matched to conditions. If applicable, use process enclosures, local exhaust ventilation, or other engineering controls to maintain airborne levels below recommended exposure limits. If exposure limits have not been established, maintain airborne levels to an acceptable level. Eye wash facilities and emergency shower must be available when handling this product.

Individual protection measures, such as personal protective equipment

Eye/face protection

Wear safety glasses with side shields (or goggles).

Skin protection	
Hand protection	Chemical resistant gloves are recommended.
Other	Wear suitable protective clothing.
Respiratory protection	In case of insufficient ventilation, wear suitable respiratory equipment.
Thermal hazards	Not applicable.
General hygiene considerations	When using, do not eat, drink or smoke. Always observe good personal hygiene measures, such as washing after handling the material and before eating, drinking, and/or smoking. Routinely wash work clothing and protective equipment to remove contaminants.

9. Physical and chemical properties

Appearance	Liquid.
Physical state	Gas.
Form	Aerosol.
Color	Brown
Odor	Slight petroleum odor, Cherry
Odor threshold	Not established
pH	Not applicable
Melting point/freezing point	< -58 °F (< -50 °C)
Initial boiling point and boiling range	383 °F (195 °C) @ 101 kPa
Flash point	174.2 °F (79.0 °C) Tag Closed Cup (dispensed liquid)
Evaporation rate	< 0.1 BuAc
Flammability (solid, gas)	Flammable gas.
Upper/lower flammability or explosive limits	
Flammability limit - lower (%)	0.6 %
Flammability limit - upper (%)	7 %
Explosive limit - lower (%)	Not available.
Explosive limit - upper (%)	Not available.
Vapor pressure	< 0.05 mm Hg @ 20°C (dispensed liquid)
Vapor density	4.7 (air = 1)
Relative density	Not available.
Solubility(ies)	
Solubility (water)	< 3 %
Partition coefficient (n-octanol/water)	< 1
Auto-ignition temperature	> 442.4 °F (> 228 °C)
Decomposition temperature	Not established
Viscosity	< 7 cSt
Viscosity temperature	77 °F (25 °C)
Other information	
Heat of combustion	> 30 kJ/g
Percent volatile	92 - 95 %
Specific gravity	0.82 - 0.86 @ 20°C

10. Stability and reactivity

Reactivity	The product is stable and non-reactive under normal conditions of use, storage and transport.
Chemical stability	Material is stable under normal conditions.
Possibility of hazardous reactions	Hazardous polymerization does not occur.
Conditions to avoid	Avoid heat, sparks, open flames and other ignition sources. Avoid temperatures exceeding the flash point. Contact with incompatible materials.

Incompatible materials Strong oxidizing agents.
Hazardous decomposition products Carbon oxides.

11. Toxicological information

Information on likely routes of exposure

Inhalation Vapors have a narcotic effect and may cause headache, fatigue, dizziness and nausea.
Skin contact Causes skin irritation.
Eye contact Causes serious eye irritation.
Ingestion May cause discomfort if swallowed.

Symptoms related to the physical, chemical and toxicological characteristics Irritating to eyes, respiratory system and skin. Symptoms may include stinging, tearing, redness, swelling, and blurred vision. Exposure may cause temporary irritation, redness, or discomfort. Vapors have a narcotic effect and may cause headache, fatigue, dizziness and nausea.

Information on toxicological effects

Acute toxicity Narcotic effects.

Components	Species	Test Results
Distillates Petroleum, Hydrotreated Light (CAS 64742-47-8)		
Acute		
<i>Dermal</i>		
LD50	Rabbit	> 2000 mg/kg > 2000 mg/kg, 24 Hours
<i>Inhalation</i>		
LC50	Cat	> 6.4 mg/l, 6 Hours
	Rat	> 7.5 mg/l, 6 Hours > 4.3 mg/l, 4 Hours > 0.1 mg/l, 8 Hours
<i>Oral</i>		
LD50	Rat	> 5000 mg/kg
Petroleum Oil (CAS 64742-52-5)		
Acute		
<i>Dermal</i>		
LD50	Rabbit	> 2000 mg/kg > 2000 mg/kg, 24 Hours
<i>Inhalation</i>		
LC50	Rat	2.18 mg/l, 4 Hours
<i>Oral</i>		
LD50	Rat	5000 mg/kg
Skin corrosion/irritation	Causes skin irritation.	
Serious eye damage/eye irritation	Causes serious eye irritation.	
Respiratory or skin sensitization		
Respiratory sensitization	Not a respiratory sensitizer.	
Skin sensitization	This product is not expected to cause skin sensitization.	
Germ cell mutagenicity	No data available to indicate product or any components present at greater than 0.1% are mutagenic or genotoxic.	
Carcinogenicity	This product is not considered to be a carcinogen by IARC, ACGIH, NTP, or OSHA.	
OSHA Specifically Regulated Substances (29 CFR 1910.1001-1050)		
Not listed.		
Reproductive toxicity	This product is not expected to cause reproductive or developmental effects.	
Specific target organ toxicity - single exposure	Narcotic effects.	

Specific target organ toxicity - repeated exposure	Based on available data, the classification criteria are not met.
Aspiration hazard	Not likely, due to the form of the product.
Chronic effects	Prolonged inhalation may be harmful.

12. Ecological information

Ecotoxicity The product is not classified as environmentally hazardous. However, this does not exclude the possibility that large or frequent spills can have a harmful or damaging effect on the environment.

Components	Species	Test Results
Distillates Petroleum, Hydrotreated Light (CAS 64742-47-8)		
Aquatic		
Fish	LC50 Rainbow trout, donaldson trout (Oncorhynchus mykiss)	2.9 mg/l, 96 hours

Persistence and degradability Not inherently biodegradable.

Bioaccumulative potential Not available.

Partition coefficient n-octanol / water (log Kow)
LPS@ 2 (Aerosol) < 1

Mobility in soil No data available.

Other adverse effects None known.

13. Disposal considerations

Disposal instructions Consult authorities before disposal. Contents under pressure. Do not puncture, incinerate or crush. Dispose of contents/container in accordance with local/regional/national/international regulations.

Local disposal regulations Dispose in accordance with all applicable regulations.

Hazardous waste code D003: Waste Reactive material

Waste from residues / unused products Dispose of in accordance with local regulations. Empty containers or liners may retain some product residues. This material and its container must be disposed of in a safe manner (see: Disposal instructions).

Contaminated packaging Empty containers should be taken to an approved waste handling site for recycling or disposal. Since emptied containers may retain product residue, follow label warnings even after container is emptied. Do not re-use empty containers.

14. Transport information

DOT

UN number	UN1950
UN proper shipping name	Aerosols, flammable
Transport hazard class(es)	
Class	2.1
Subsidiary risk	-
Label(s)	2.1
Packing group	Not applicable.
Environmental hazards	
Marine pollutant	No
Special precautions for user	Read safety instructions, SDS and emergency procedures before handling. Read safety instructions, SDS and emergency procedures before handling.
Packaging exceptions	306
Packaging non bulk	None
Packaging bulk	None

IATA

UN number	UN1950
UN proper shipping name	Aerosols, flammable
Transport hazard class(es)	
Class	2.1
Subsidiary risk	-
Label(s)	2.1
Packing group	Not applicable.
Environmental hazards	No.
ERG Code	10L

Special precautions for user Read safety instructions, SDS and emergency procedures before handling. Read safety instructions, SDS and emergency procedures before handling.

Other information

Passenger and cargo aircraft Allowed.

Cargo aircraft only Allowed.

IMDG

UN number UN1950

UN proper shipping name AEROSOLS, flammable

Transport hazard class(es)

Class 2.1

Subsidiary risk -

Label(s) 2.1

Packing group Not applicable.

Environmental hazards

Marine pollutant No

EmS Not available.

Special precautions for user Read safety instructions, SDS and emergency procedures before handling. Read safety instructions, SDS and emergency procedures before handling.

Transport in bulk according to Annex II of MARPOL 73/78 and the IBC Code Not applicable.

DOT



IATA; IMDG



15. Regulatory information

US federal regulations This product is a "Hazardous Chemical" as defined by the OSHA Hazard Communication Standard, 29 CFR 1910.1200.

TSCA Section 12(b) Export Notification (40 CFR 707, Subpt. D)

Not regulated.

CERCLA Hazardous Substance List (40 CFR 302.4)

Not listed.

SARA 304 Emergency release notification

Not regulated.

OSHA Specifically Regulated Substances (29 CFR 1910.1001-1050)

Not listed.

Superfund Amendments and Reauthorization Act of 1986 (SARA)

Hazard categories Immediate Hazard - Yes
 Delayed Hazard - No
 Fire Hazard - Yes
 Pressure Hazard - Yes
 Reactivity Hazard - No

SARA 302 Extremely hazardous substance

Not listed.

SARA 311/312 Hazardous chemical Yes

SARA 313 (TRI reporting)

Not regulated.

Other federal regulations**Clean Air Act (CAA) Section 112 Hazardous Air Pollutants (HAPs) List**

Not regulated.

Clean Air Act (CAA) Section 112(r) Accidental Release Prevention (40 CFR 68.130)

Not regulated.

Safe Drinking Water Act (SDWA) Not regulated.

US state regulations**US. California Controlled Substances. CA Department of Justice (California Health and Safety Code Section 11100)**

Not listed.

US. Massachusetts RTK - Substance List

Carbon Dioxide (CAS 124-38-9)

US. New Jersey Worker and Community Right-to-Know Act

Carbon Dioxide (CAS 124-38-9)

US. Pennsylvania Worker and Community Right-to-Know Law

Carbon Dioxide (CAS 124-38-9)

US. Rhode Island RTK

Not regulated.

US. California Proposition 65

California Safe Drinking Water and Toxic Enforcement Act of 1986 (Proposition 65): This material is not known to contain any chemicals currently listed as carcinogens or reproductive toxins.

International Inventories

Country(s) or region	Inventory name	On inventory (yes/no)*
Australia	Australian Inventory of Chemical Substances (AICS)	Yes
Canada	Domestic Substances List (DSL)	Yes
Canada	Non-Domestic Substances List (NDSL)	No
China	Inventory of Existing Chemical Substances in China (IECSC)	No
Europe	European Inventory of Existing Commercial Chemical Substances (EINECS)	Yes
Europe	European List of Notified Chemical Substances (ELINCS)	No
Japan	Inventory of Existing and New Chemical Substances (ENCS)	No
Korea	Existing Chemicals List (ECL)	Yes
New Zealand	New Zealand Inventory	No
Philippines	Philippine Inventory of Chemicals and Chemical Substances (PICCS)	Yes
United States & Puerto Rico	Toxic Substances Control Act (TSCA) Inventory	Yes

*A "Yes" indicates that all components of this product comply with the inventory requirements administered by the governing country(s)

A "No" indicates that one or more components of the product are not listed or exempt from listing on the inventory administered by the governing country(s).

16. Other information, including date of preparation or last revision

Issue date 09-22-2014

Version # 01

Disclaimer

The information provided in this Safety Data Sheet is correct to the best of our knowledge, information and belief at the date of its publication. The information given is designed only as a guidance for safe handling, use, processing, storage, transportation, disposal and release and is not to be considered a warranty or quality specification. The information relates only to the specific material designated and may not be valid for such material used in combination with any other materials or in any process, unless specified in the text.

Revision Information

Product and Company Identification: Product Uses
Composition / Information on Ingredients: Ingredients
Physical & Chemical Properties: Multiple Properties
Ecological Information: Ecotox Property Data
Transport Information: Proper Shipping Name/Packing Group
Regulatory Information: United States
HazReg Data: North America
GHS: Classification



SAFETY DATA SHEET

1. Identification

Product identifier	LPS® All Purpose Anti-Seize
Other means of identification	
Part Number	04108, 04110, 04105
Recommended use	An all-purpose, anti-seize lubricant designed to prevent seizure and galling and resist settling and hardening of welding.
Recommended restrictions	None known.
Manufacturer/Importer/Supplier/Distributor information	
Manufacturer	
Manufacturer	
Company name	LPS Laboratories, a division of Illinois Tool Works, Inc.
Address	4647 Hugh Howell Rd. Tucker, GA 30084
Country	(U.S.A.) Tel: +1 770-243-8800
In Case of Emergency	1-800-424-9300 (inside U.S.) +001 703-527-3887 (outside U.S.)
Website	www.lpslabs.com
E-mail	sds@lpslabs.com

2. Hazard(s) identification

Physical hazards	Not classified.
Health hazards	Not classified.
Environmental hazards	Not classified.
OSHA defined hazards	Not classified.
Label elements	
Hazard symbol	None.
Signal word	None.
Hazard statement	The mixture does not meet the criteria for classification.
Precautionary statement	
Prevention	Observe good industrial hygiene practices.
Response	Wash hands after handling.
Storage	Store away from incompatible materials.
Disposal	Dispose of waste and residues in accordance with local authority requirements.
Hazard(s) not otherwise classified (HNOC)	None known.
Supplemental information	None.

3. Composition/information on ingredients

Mixtures

Chemical name	Common name and synonyms	CAS number	%
Molybdenum (IV) sulfide		1317-33-5	1 - 5
Zinc oxide		1314-13-2	1 - 2

4. First-aid measures

Inhalation	Move to fresh air. Call a physician if symptoms develop or persist.
Skin contact	Wash off with soap and water. Get medical attention if irritation develops and persists.
Eye contact	Rinse with water. Get medical attention if irritation develops and persists.

Ingestion	Rinse mouth. Get medical attention if symptoms occur.
Most important symptoms/effects, acute and delayed	Direct contact with eyes may cause temporary irritation. Exposed individuals may experience eye tearing, redness, and discomfort.
Indication of immediate medical attention and special treatment needed	Treat symptomatically.
General information	Ensure that medical personnel are aware of the material(s) involved, and take precautions to protect themselves.

5. Fire-fighting measures

Suitable extinguishing media	Water fog. Foam. Dry chemical powder. Carbon dioxide (CO ₂).
Unsuitable extinguishing media	Do not use a solid water stream as it may scatter and spread fire.
Specific hazards arising from the chemical	During fire, gases hazardous to health may be formed.
Special protective equipment and precautions for firefighters	Self-contained breathing apparatus and full protective clothing must be worn in case of fire.
Fire fighting equipment/instructions	Use water spray to cool unopened containers.
Specific methods	Use standard firefighting procedures and consider the hazards of other involved materials.
General fire hazards	No unusual fire or explosion hazards noted.

6. Accidental release measures

Personal precautions, protective equipment and emergency procedures	Keep unnecessary personnel away. Do not touch damaged containers or spilled material unless wearing appropriate protective clothing. Use personal protection recommended in Section 8 of the SDS.
Methods and materials for containment and cleaning up	Stop the flow of material, if this is without risk. Prevent entry into waterways, sewer, basements or confined areas. Following product recovery, flush area with water. For waste disposal, see section 13 of the SDS.
Environmental precautions	Avoid discharge into drains, water courses or onto the ground.

7. Handling and storage

Precautions for safe handling	Avoid prolonged exposure. Observe good industrial hygiene practices.
Conditions for safe storage, including any incompatibilities	Store in original tightly closed container. Store away from incompatible materials (see Section 10 of the SDS).

8. Exposure controls/personal protection

Occupational exposure limits

US. OSHA Table Z-1 Limits for Air Contaminants (29 CFR 1910.1000)

Components	Type	Value	Form
Zinc Oxide (CAS 1314-13-2)	PEL	5 mg/m ³	Fume.
		5 mg/m ³	Respirable fraction.
		15 mg/m ³	Total dust.

US. ACGIH Threshold Limit Values

Components	Type	Value	Form
Zinc Oxide (CAS 1314-13-2)	STEL	10 mg/m ³	Respirable fraction.
	TWA	2 mg/m ³	Respirable fraction.

US. NIOSH: Pocket Guide to Chemical Hazards

Components	Type	Value	Form
Zinc Oxide (CAS 1314-13-2)	Ceiling	15 mg/m ³	Dust.
	STEL	10 mg/m ³	Fume.
	TWA	5 mg/m ³	Dust.
		5 mg/m ³	Fume.

Biological limit values No biological exposure limits noted for the ingredient(s).

Appropriate engineering controls	Good general ventilation (typically 10 air changes per hour) should be used. Ventilation rates should be matched to conditions. If applicable, use process enclosures, local exhaust ventilation, or other engineering controls to maintain airborne levels below recommended exposure limits. If exposure limits have not been established, maintain airborne levels to an acceptable level.
Individual protection measures, such as personal protective equipment	
Eye/face protection	Wear safety glasses with side shields (or goggles).
Skin protection	
Hand protection	Wear appropriate chemical resistant gloves.
Other	Wear suitable protective clothing.
Respiratory protection	In case of insufficient ventilation, wear suitable respiratory equipment.
Thermal hazards	Wear appropriate thermal protective clothing, when necessary.
General hygiene considerations	Always observe good personal hygiene measures, such as washing after handling the material and before eating, drinking, and/or smoking. Routinely wash work clothing and protective equipment to remove contaminants.

9. Physical and chemical properties

Appearance	Paste.
Physical state	Solid.
Form	Solid.
Color	Dark grey.
Odor	Hydrocarbon-like.
Odor threshold	Not available.
pH	Not available.
Melting point/freezing point	500 °F (260 °C)
Initial boiling point and boiling range	> 600.8 °F (> 316 °C)
Flash point	> 429.8 °F (> 221.0 °C)
Evaporation rate	Not available.
Flammability (solid, gas)	Not available.
Upper/lower flammability or explosive limits	
Flammability limit - lower (%)	Not available.
Flammability limit - upper (%)	Not available.
Explosive limit - lower (%)	Not available.
Explosive limit - upper (%)	Not available.
Vapor pressure	Not available.
Vapor density	Not available.
Relative density	Not available.
Solubility(ies)	
Solubility (water)	Insoluble
Partition coefficient (n-octanol/water)	Not available.
Auto-ignition temperature	Not available.
Decomposition temperature	Not available.
Viscosity	Not available.
Other information	
Specific gravity	1.19
VOC (Weight %)	Negligible

10. Stability and reactivity

Reactivity	The product is stable and non-reactive under normal conditions of use, storage and transport.
Chemical stability	Material is stable under normal conditions.

Possibility of hazardous reactions	Hazardous polymerization does not occur.
Conditions to avoid	Heat, flames and sparks.
Incompatible materials	Strong oxidizing agents.
Hazardous decomposition products	No hazardous decomposition products are known.

11. Toxicological information

Information on likely routes of exposure

Inhalation	No adverse effects due to inhalation are expected.
Skin contact	Frequent or prolonged contact may defat and dry the skin, leading to discomfort and dermatitis.
Eye contact	Direct contact with eyes may cause temporary irritation.
Ingestion	May cause discomfort if swallowed. However, ingestion is not likely to be a primary route of occupational exposure.

Symptoms related to the physical, chemical and toxicological characteristics
 Direct contact with eyes may cause temporary irritation. Exposure may cause temporary irritation, redness, or discomfort.

Information on toxicological effects

Acute toxicity Expected to be a low hazard for usual industrial or commercial handling by trained personnel.

Components	Species	Test Results
Zinc oxide (CAS 1314-13-2)		
Acute		
<i>Inhalation</i>		
LC50	Mouse	> 5.7 mg/l, 4 Hours
	Rat	> 5700 mg/m3
<i>Oral</i>		
LD50	Mouse	2000 - 5000 mg/kg
	Rat	> 5 g/kg
<i>Other</i>		
LD50	Rat	240 mg/kg

Skin corrosion/irritation Prolonged skin contact may cause temporary irritation.

Serious eye damage/eye irritation Direct contact with eyes may cause temporary irritation.

Respiratory or skin sensitization

Respiratory sensitization	Not a respiratory sensitizer.
Skin sensitization	This product is not expected to cause skin sensitization.

Germ cell mutagenicity No data available to indicate product or any components present at greater than 0.1% are mutagenic or genotoxic.

Carcinogenicity This product is not considered to be a carcinogen by IARC, ACGIH, NTP, or OSHA.

OSHA Specifically Regulated Substances (29 CFR 1910.1001-1050)

Not listed.

Reproductive toxicity This product is not expected to cause reproductive or developmental effects.

Specific target organ toxicity - single exposure Not classified.

Specific target organ toxicity - repeated exposure Not classified.

Aspiration hazard Not likely, due to the form of the product.

Chronic effects None known.

Further information This product has no known adverse effect on human health.

12. Ecological information

Ecotoxicity The product is not classified as environmentally hazardous. However, this does not exclude the possibility that large or frequent spills can have a harmful or damaging effect on the environment.

Components	Species	Test Results
Zinc oxide (CAS 1314-13-2)		
Aquatic		
Fish	LC50	Fathead minnow (<i>Pimephales promelas</i>) 2246 mg/l, 96 hours
Persistence and degradability	No data is available on the degradability of this product.	
Bioaccumulative potential	No data available.	
Mobility in soil	No data available.	
Other adverse effects	None known.	
13. Disposal considerations		
Disposal instructions	Collect and reclaim or dispose in sealed containers at licensed waste disposal site.	
Local disposal regulations	Dispose in accordance with all applicable regulations.	
Hazardous waste code	The waste code should be assigned in discussion between the user, the producer and the waste disposal company.	
Waste from residues / unused products	Dispose of in accordance with local regulations. Empty containers or liners may retain some product residues. This material and its container must be disposed of in a safe manner (see: Disposal instructions).	
Contaminated packaging	Empty containers should be taken to an approved waste handling site for recycling or disposal. Since emptied containers may retain product residue, follow label warnings even after container is emptied.	

14. Transport information

DOT

Not regulated as dangerous goods.

IATA

Not regulated as dangerous goods.

IMDG

Not regulated as dangerous goods.

Transport in bulk according to Annex II of MARPOL 73/78 and the IBC Code Not applicable.

15. Regulatory information

US federal regulations All components are on the U.S. EPA TSCA Inventory List. This product is not known to be a "Hazardous Chemical" as defined by the OSHA Hazard Communication Standard, 29 CFR 1910.1200.

TSCA Section 12(b) Export Notification (40 CFR 707, Subpt. D)

Not regulated.

CERCLA Hazardous Substance List (40 CFR 302.4)

Not listed.

SARA 304 Emergency release notification

Not regulated.

OSHA Specifically Regulated Substances (29 CFR 1910.1001-1050)

Not listed.

Superfund Amendments and Reauthorization Act of 1986 (SARA)

Hazard categories Immediate Hazard - No
Delayed Hazard - No
Fire Hazard - No
Pressure Hazard - No
Reactivity Hazard - No

SARA 302 Extremely hazardous substance

Not listed.

SARA 311/312 Hazardous chemical No

SARA 313 (TRI reporting)

Not regulated.

Other federal regulations

Clean Air Act (CAA) Section 112 Hazardous Air Pollutants (HAPs) List

Not regulated.

Clean Air Act (CAA) Section 112(r) Accidental Release Prevention (40 CFR 68.130)

Not regulated.

Safe Drinking Water Act (SDWA)

Not regulated.

US state regulations

US. California Controlled Substances. CA Department of Justice (California Health and Safety Code Section 11100)

Not listed.

US. Massachusetts RTK - Substance List

Molybdenum (IV) sulfide (CAS 1317-33-5)

Zinc oxide (CAS 1314-13-2)

US. New Jersey Worker and Community Right-to-Know Act

Zinc oxide (CAS 1314-13-2)

US. Pennsylvania Worker and Community Right-to-Know Law

Zinc oxide (CAS 1314-13-2)

US. Rhode Island RTK

Not regulated.

US. California Proposition 65

California Safe Drinking Water and Toxic Enforcement Act of 1986 (Proposition 65): This material is not known to contain any chemicals currently listed as carcinogens or reproductive toxins.

International Inventories

Country(s) or region	Inventory name	On inventory (yes/no)*
Australia	Australian Inventory of Chemical Substances (AICS)	No
Canada	Domestic Substances List (DSL)	Yes
Canada	Non-Domestic Substances List (NDSL)	No
China	Inventory of Existing Chemical Substances in China (IECSC)	Yes
Europe	European Inventory of Existing Commercial Chemical Substances (EINECS)	Yes
Europe	European List of Notified Chemical Substances (ELINCS)	No
Japan	Inventory of Existing and New Chemical Substances (ENCS)	No
Korea	Existing Chemicals List (ECL)	No
New Zealand	New Zealand Inventory	Yes
Philippines	Philippine Inventory of Chemicals and Chemical Substances (PICCS)	Yes
United States & Puerto Rico	Toxic Substances Control Act (TSCA) Inventory	Yes

*A "Yes" indicates that all components of this product comply with the inventory requirements administered by the governing country(s)

A "No" indicates that one or more components of the product are not listed or exempt from listing on the inventory administered by the governing country(s).

16. Other information, including date of preparation or last revision

Issue date 11-12-2014

Version # 01

Disclaimer LPS Laboratories cannot anticipate all conditions under which this information and its product, or the products of other manufacturers in combination with its product, may be used. It is the user's responsibility to ensure safe conditions for handling, storage and disposal of the product, and to assume liability for loss, injury, damage or expense due to improper use. The information provided in this Safety Data Sheet is correct to the best of our knowledge, information and belief at the date of its publication. The information given is designed only as a guidance for safe handling, use, processing, storage, transportation, disposal and release and is not to be considered a warranty or quality specification. The information relates only to the specific material designated and may not be valid for such material used in combination with any other materials or in any process, unless specified in the text.



MATERIAL SAFETY DATA SHEET

LPS® ThermaPlex® Multi-Purpose Bearing Grease

Revision Date: March 21, 2011

Supersedes: December 2, 2008

Section 1 – Identification

Product Name:	LPS® ThermaPlex® Multi-Purpose Bearing Grease
Part Number(s):	70614, 70606, 70635, 70655, C70614, C70606, C70635, C70655
Chemical Name:	Petroleum Hydrocarbon
Product Use:	A lubricating grease intended for all types of industrial bearing applications.
Manufacturer Information:	LPS Laboratories, 4647 Hugh Howell Rd., Tucker, GA, USA 30084
	TEL: USA & Canada: 1 800 241-8334 Outside USA and Canada: +1 770 243-8800
	FAX: USA & Canada: 1 800 543-1563 Outside USA and Canada: +1 770 243-8899
Emergency Telephone Number:	Chemtrec: USA & Canada: 1-800-424-9300; Outside USA and Canada: +1 703 527-3887
Website:	http://www.lpslabs.com

PLAIN LANGUAGE HAZARD SUMMARY

Material Safety Data Sheets can be confusing. Federal and State laws require us to include a great deal of technical information that probably won't help the non-professional. LPS includes this "PLAIN LANGUAGE HAZARD SUMMARY" to address the questions and concerns of the average worker. If you have additional health, safety or product questions, don't hesitate to call us at 800/241-8334.

Worker Toxicity

LPS® ThermaPlex® Multi-Purpose Bearing Grease is an industrial lubricant. LPS® ThermaPlex® Multi-Purpose Bearing Grease is not a hazardous substance as defined by 29CFR 1910.1200. For more exposure and first aid information, refer to MSDS Sections 2, 8 and 11.

Flammability

LPS® ThermaPlex® Multi-Purpose Bearing Grease is not considered flammable. However, it will burn in a fire.

Disposal

Dispose of in accordance with local, state, provincial, and federal regulations. See section 13 for more details.



MATERIAL SAFETY DATA SHEET

LPS[®] ThermaPlex[®] Multi-Purpose Bearing Grease

Revision Date: March 21, 2011

Supersedes: December 2, 2008

Section 2 – Hazards identification

This material is considered non-hazardous by the OSHA Hazard Communication Standard (29 CFR 1910.1200). This product has been classified in accordance with the hazard criteria of the Controlled Products Regulations and the MSDS contains all the information required by the Controlled Products Regulations.

Emergency Overview:

Aerosol: Not applicable

Bulk: WARNING: Prolonged or repeated skin contact may cause irritation.

Primary route(s) of entry: Skin and eye contact.

Potential Acute Health Effects:

Eyes: Irritating to eyes

Skin: Repeated exposure may cause skin dryness or defatting of skin.

Inhalation: Oil mist may cause irritation of the respiratory tract.

Ingestion: Product has a low order of acute oral toxicity.

Potential Chronic Health Effects:

Carcinogenic Effects: NTP: No IARC: No OSHA: No ACGIH: No

Mutagenic Effects: None

Teratogenic Effects: None

Target Organs: None

Medical conditions aggravated by exposure: None known from normal exposure.

Signs and Symptoms:

Stinging in eyes. Repeated or prolonged skin contact can cause redness, irritation, and scaling of the skin (dermatitis).

Section 3 – Composition / Information on Ingredients

Component	CASRN	Weight Percent
-----------	-------	----------------

No hazardous ingredients are present at or above 1%.
This product is not WHMIS Controlled.



MATERIAL SAFETY DATA SHEET

LPS® ThermaPlex® Multi-Purpose Bearing Grease

Revision Date: March 21, 2011

Supersedes: December 2, 2008

Section 4 – First Aid Measures

- Eyes:** Check for and remove contact lenses. If irritation or redness develops, flush eyes with cool, clean, low-pressure water for at least 15 minutes. Hold eyelids apart to ensure complete irrigation of the eye and eyelid tissue. Do not use eye ointment. Seek medical attention if irritation persists.
- Skin:** Remove contaminated shoes and clothing. Clean affected area thoroughly with mild soap and water. Do not use ointments. Seek medical attention if irritation persists.
- Inhalation:** Immediately move victim to fresh air. If victim is not breathing, immediately begin rescue breathing. If heart has stopped, immediately begin cardiopulmonary resuscitation (CPR). If breathing is difficult, seek medical attention immediately.
- Ingestion:** Do NOT induce vomiting unless directed to do so by medical personnel. Never give anything by mouth to an unconscious person. If spontaneous vomiting is about to occur, place victim's head below knees. If victim is drowsy or unconscious, place on the left side with head down. Do not leave victim unattended. Seek medical attention immediately.

Section 5 – Fire Fighting Measures

Products of Combustion: Carbon monoxide and carbon dioxide.

General Fire Hazards: High heat will cause product to boil, evolving vapor that could cause explosive rupture of closed containers.

Firefighting media: SMALL FIRE: Use DRY chemical powder.
LARGE FIRE: Use CO₂, water spray, fog or foam.

Sensitivity to Impact: None. **Sensitivity to Static Discharge:** None.

Protection Clothing (Fire): Firefighters must use full bunker gear including NIOSH-approved positive pressure self-contained breathing apparatus to protect against potential hazardous combustion or decomposition products and oxygen deficiencies.

Special Remarks on Explosion Hazards: None

Section 6 – Accidental Release Measures

- | | |
|-------------------------------|---|
| Containment Procedures | <p>Small Spill and Leak: Absorb with an inert material and dispose of properly.</p> <p>Large Spill and Leak: Prevent material from entering sewers and drains. Pick up for disposal using absorbent pads, sand, or other inert non-combustible absorbent materials. Place into appropriate waste containers for later disposal.</p> |
| Clean-Up Procedures | Recover free product and place in suitable container for disposal. |
| Evacuation Procedures | Ventilate area of leak or spill. Keep unnecessary and unprotected people away. |
| Special Procedures | Remove all sources of ignition. Ventilate area. Wear appropriate protective equipment during cleanup. Be aware of spilled material on walking surfaces – this product is slippery. |

Page 3 of 7



MATERIAL SAFETY DATA SHEET

LPS® ThermaPlex® Multi-Purpose Bearing Grease

Revision Date: March 21, 2011

Supersedes: December 2, 2008

Section 7 – Handling and Storage

Handling: Avoid contact with skin. Wash thoroughly after handling.

Storage: Keep container sealed until ready for use. Keep container in a cool, well-ventilated area. Store between 40°F and 120°F (4.4°C and 49°C).

Precautions to be taken in handling and storage: Keep container in a cool, well-ventilated area. Avoid breathing vapors.

Section 8 – Exposure Controls / Personal Protection

Engineering Controls: Provide general and/or local exhaust ventilation to keep exposures below 5 mg/m³ oil mist in air.

Personal Protection:

Eye protection Safety glasses with side shields conforming to appropriate regulations. Eye wash fountain and emergency shower facilities are recommended.

Hand protection Normally no hand protection is required; however, using chemical resistant gloves is recommended.

Respiratory protection Typical use of this product under normal conditions does not require the use of respiratory protection. If airborne concentrations are above the applicable exposure limit (listed above), use NIOSH approved respiratory protection (i.e., organic vapor cartridge).

General Hygiene Considerations Wash thoroughly after handling.



MATERIAL SAFETY DATA SHEET

LPS® ThermaPlex® Multi-Purpose Bearing Grease

Revision Date: March 21, 2011

Supersedes: December 2, 2008

Section 9 – Physical and Chemical Properties

Appearance:	Paste	Color:	Blue
Odor:	Petroleum	Evaporation Rate:	<1 (BuAc=1)
Solubility Description:	Not soluble in water	Flash Point:	>230°C (446°F)
Boiling Point:	Not Established	Flash Point Method:	TCC
Specific Gravity (Water=1):	0.89 – 0.94 @ 20°C	Decomposition Temperature:	Not Established
Vapor Density (Air=1):	>1	Auto Ignition Temperature:	Not Established
Vapor Pressure:	Not Established	Flammable limits (estimated):	LOWER: NE UPPER: NE
Rule 1171 PpC:	Not Applicable	Partition Coefficient (octanol/water):	Not Established
V.O.C. Content:	Aerosol: not applicable Bulk: 0%, 0 g/L, 0 lb/gal per CARB/OTC/EPA Regulations	Odor Threshold:	Not Established
Melting Point:	Not Established	Viscosity:	Not Established
pH:	Not Applicable	Volatiles:	0%
Heat of combustion:	Aerosol: Not Applicable Bulk: Not Established		

Section 10 – Chemical Stability and Reactivity

Chemical Stability:	Product is stable under recommended storage conditions.
Conditions to Avoid:	No specific measures to avoid.
Incompatibility:	Reactive or incompatible with oxidizing agents.
Hazardous Decomposition:	These products are carbon oxides (CO, CO ₂).
Hazardous Polymerization:	Will not occur.

Section 11 – Toxicological Information

A: General Product Information

An acute toxicity study of this product has not been conducted. Information given in the section relates only to individual constituents contained in this preparation.

B: Component Analysis

None



MATERIAL SAFETY DATA SHEET

LPS[®] ThermaPlex[®] Multi-Purpose Bearing Grease

Revision Date: March 21, 2011

Supersedes: December 2, 2008

Section 12 – Ecological Information

Mobility:	Non-volatile. Absorbed slowly into soil	Persistence and degradability:	Only slightly biodegradable
Bioaccumulative potential:	No bioaccumulation potential	Other adverse effects:	None known

Section 13 – Disposal Considerations

Waste Status:	In its purchased form, this material does not meet the definition of a RCRA hazardous waste (40 CFR 261).
Disposal:	Waste must be disposed of in accordance with national, regional, provincial, and local environmental control regulations.
Note:	Chemical additions to, processing of, or otherwise altering this material may make this waste management information inaccurate, incomplete, or otherwise inappropriate. Furthermore, state and local waste disposal requirements may be more restrictive than federal laws and regulations.

Section 14 – Transportation Information

This material is not regulated by any mode of transportation.

The preceding information is subject to change and must be verified prior to shipment. It is the responsibility of anyone offering hazardous materials for shipment to ensure compliance with all applicable regulations.

Section 15 – Regulatory Information

U.S. Federal Regulations

RCRA Hazardous Waste No.: None

Comprehensive Environmental Response and Liability Act of 1980 (CERCLA): None

Toxic Substances Control Act (TSCA):

All components of this product are TSCA inventory listed and/or are exempt.

Superfund Amendments and Reauthorization Act (SARA) Title III
SARA Section 311/312 (40 CFR 370) Hazard Categories: None

This product contains the following toxic chemical(s) subject to reporting requirements of SARA Section 313 (40 CFR 372): No individual section 313 component is present at or above 1%

Section 112 Hazardous Air Pollutants (HAPs): None



MATERIAL SAFETY DATA SHEET

LPS® ThermaPlex® Multi-Purpose Bearing Grease

Revision Date: March 21, 2011

Supersedes: December 2, 2008

State Regulations

California: This product does not contain chemical(s) known to the State of California to cause cancer, birth defects or reproductive harm.

California and OTC States: This product is not regulated by consumer regulations.

New Jersey RTK:

Aerosol: Not applicable

Bulk: Petroleum Oil 64742-52-5 • Calcium Carbonate 471-34-1 • Lithium 12-Hydroxystearate 7620-77-1 • Olefin sulfide NJTSR No. 800969-5422P

International Regulations

Canadian Environmental Protection Act: All of the components of this product are included on the Canadian Domestic Substances list (DSL).

Canadian Workplace Hazardous Materials Information System (WHMIS):

This product has been classified in accordance with the hazard criteria of the Controlled Products Regulations and the MSDS contains all the information required by the Controlled Products Regulations.

WHMIS Classification:

Not WHMIS Controlled

Other Regulations

Montreal Protocol listed ingredients: None.
 Stockholm Convention listed ingredients: None.
 Rotterdam Convention listed ingredients: None.
 RoHS Compliant: Yes.

Section 16 • Other Information

MSDS# 170614 Responsible Name: Clea George Regulatory Affairs Coordinator Telephone: +1 770 243-8800	HMIS 1996	HMIS III	NFPA
	Health: 1	Health: [1]	
	Flammability: 1	Flammability aerosol: NA Flammability bulk: 1	
	Reactivity: 0	Physical Hazard aerosol: NA Physical Hazard bulk: 0	

Notice to Reader:

To the best of our knowledge, the information contained herein is accurate. However, neither the above named supplier nor any of its subsidiaries assumes any liability whatsoever for the accuracy or completeness of the information contained herein. Final determination of suitability of any material is the sole responsibility of the user. All materials may present unknown hazards and should be used with caution. Although certain hazards are described herein, we cannot guarantee that these are the only hazards that exist.

Clea L. George, Regulatory Affairs Coordinator
 LPS Laboratories, A division of Illinois Tool Works



Product Name: MOBIL VACTRA OIL HEAVY MEDIUM
Revision Date: 16 Mar 2015
Page 1 of 10

SAFETY DATA SHEET

SECTION 1 PRODUCT AND COMPANY IDENTIFICATION

PRODUCT

Product Name: MOBIL VACTRA OIL HEAVY MEDIUM
Product Description: Base Oil and Additives
Product Code: 201560503060, 580407-00, 970015
Intended Use: Lubricant

COMPANY IDENTIFICATION

Supplier: EXXON MOBIL CORPORATION
22777 Springwoods Village Parkway
Spring, TX. 77389 USA
24 Hour Health Emergency 609-737-4411
Transportation Emergency Phone 800-424-9300 or 703-527-3887 CHEMTREC
Product Technical Information 800-662-4525
MSDS Internet Address <http://www.exxon.com>, <http://www.mobil.com>

SECTION 2 HAZARDS IDENTIFICATION

This material is not hazardous according to regulatory guidelines (see (M)SDS Section 15).

Other hazard information:

HAZARD NOT OTHERWISE CLASSIFIED (HNOC): None as defined under 29 CFR 1910.1200.

PHYSICAL / CHEMICAL HAZARDS

No significant hazards.

HEALTH HAZARDS

High-pressure injection under skin may cause serious damage. Excessive exposure may result in eye, skin, or respiratory irritation.

ENVIRONMENTAL HAZARDS

No significant hazards.

NFPA Hazard ID:	Health: 0	Flammability: 1	Reactivity: 0
HMIS Hazard ID:	Health: 0	Flammability: 1	Reactivity: 0

NOTE: This material should not be used for any other purpose than the intended use in Section 1 without expert advice. Health studies have shown that chemical exposure may cause potential human health risks which may vary from person to person.



Product Name: MOBIL VACTRA OIL HEAVY MEDIUM
 Revision Date: 16 Mar 2015
 Page 2 of 10

SECTION 3	COMPOSITION / INFORMATION ON INGREDIENTS
------------------	---

This material is defined as a mixture.

Hazardous Substance(s) or Complex Substance(s) required for disclosure

Name	CAS#	Concentration*	GHS Hazard Codes
2,6-DITERTBUTYL PHENOL	128-39-2	0.1 - < 0.25%	H315, H319(2A), H400(M factor 1), H410(M factor 1)

* All concentrations are percent by weight unless material is a gas. Gas concentrations are in percent by volume.

As per paragraph (i) of 29 CFR 1910.1200, formulation is considered a trade secret and specific chemical identity and exact percentage (concentration) of composition may have been withheld. Specific chemical identity and exact percentage composition will be provided to health professionals, employees, or designated representatives in accordance with applicable provisions of paragraph (i).

SECTION 4	FIRST AID MEASURES
------------------	---------------------------

INHALATION

Remove from further exposure. For those providing assistance, avoid exposure to yourself or others. Use adequate respiratory protection. If respiratory irritation, dizziness, nausea, or unconsciousness occurs, seek immediate medical assistance. If breathing has stopped, assist ventilation with a mechanical device or use mouth-to-mouth resuscitation.

SKIN CONTACT

Wash contact areas with soap and water. If product is injected into or under the skin, or into any part of the body, regardless of the appearance of the wound or its size, the individual should be evaluated immediately by a physician as a surgical emergency. Even though initial symptoms from high pressure injection may be minimal or absent, early surgical treatment within the first few hours may significantly reduce the ultimate extent of injury.

EYE CONTACT

Flush thoroughly with water. If irritation occurs, get medical assistance.

INGESTION

First aid is normally not required. Seek medical attention if discomfort occurs.

SECTION 5	FIRE FIGHTING MEASURES
------------------	-------------------------------

EXTINGUISHING MEDIA

Appropriate Extinguishing Media: Use water fog, foam, dry chemical or carbon dioxide (CO₂) to extinguish flames.

Inappropriate Extinguishing Media: Straight Streams of Water

FIRE FIGHTING



Product Name: MOBIL VACTRA OIL HEAVY MEDIUM
Revision Date: 16 Mar 2015
Page 3 of 10

Fire Fighting Instructions: Evacuate area. Prevent runoff from fire control or dilution from entering streams, sewers, or drinking water supply. Firefighters should use standard protective equipment and in enclosed spaces, self-contained breathing apparatus (SCBA). Use water spray to cool fire exposed surfaces and to protect personnel.

Hazardous Combustion Products: Smoke, Fume, Sulfur oxides, Aldehydes, Oxides of carbon, Incomplete combustion products

FLAMMABILITY PROPERTIES

Flash Point [Method]: >204°C (399°F) [ASTM D-92]

Flammable Limits (Approximate volume % in air): LEL: 0.9 UEL: 7.0

Autoignition Temperature: N/D

SECTION 6 ACCIDENTAL RELEASE MEASURES

NOTIFICATION PROCEDURES

In the event of a spill or accidental release, notify relevant authorities in accordance with all applicable regulations. US regulations require reporting releases of this material to the environment which exceed the applicable reportable quantity or oil spills which could reach any waterway including intermittent dry creeks. The National Response Center can be reached at (800)424-8802.

PROTECTIVE MEASURES

Avoid contact with spilled material. See Section 5 for fire fighting information. See the Hazard Identification Section for Significant Hazards. See Section 4 for First Aid Advice. See Section 8 for advice on the minimum requirements for personal protective equipment. Additional protective measures may be necessary, depending on the specific circumstances and/or the expert judgment of the emergency responders.

For emergency responders: Respiratory protection: respiratory protection will be necessary only in special cases, e.g., formation of mists. Half-face or full-face respirator with filter(s) for dust/organic vapor or Self Contained Breathing Apparatus (SCBA) can be used depending on the size of spill and potential level of exposure. If the exposure cannot be completely characterized or an oxygen deficient atmosphere is possible or anticipated, SCBA is recommended. Work gloves that are resistant to hydrocarbons are recommended. Gloves made of polyvinyl acetate (PVA) are not water-resistant and are not suitable for emergency use. Chemical goggles are recommended if splashes or contact with eyes is possible. Small spills: normal antistatic work clothes are usually adequate. Large spills: full body suit of chemical resistant, antistatic material is recommended.

SPILL MANAGEMENT

Land Spill: Stop leak if you can do it without risk. Recover by pumping or with suitable absorbent.

Water Spill: Stop leak if you can do it without risk. Confine the spill immediately with booms. Warn other shipping. Remove from the surface by skimming or with suitable absorbents. Seek the advice of a specialist before using dispersants.

Water spill and land spill recommendations are based on the most likely spill scenario for this material; however, geographic conditions, wind, temperature, (and in the case of a water spill) wave and current direction and speed may greatly influence the appropriate action to be taken. For this reason, local experts should be consulted. Note: Local regulations may prescribe or limit action to be taken.

ENVIRONMENTAL PRECAUTIONS

Large Spills: Dike far ahead of liquid spill for later recovery and disposal. Prevent entry into waterways,



Product Name: MOBIL VACTRA OIL HEAVY MEDIUM
Revision Date: 16 Mar 2015
Page 4 of 10

sewers, basements or confined areas.

SECTION 7 HANDLING AND STORAGE

HANDLING

Prevent small spills and leakage to avoid slip hazard. Material can accumulate static charges which may cause an electrical spark (ignition source). When the material is handled in bulk, an electrical spark could ignite any flammable vapors from liquids or residues that may be present (e.g., during switch-loading operations). Use proper bonding and/or ground procedures. However, bonding and grounds may not eliminate the hazard from static accumulation. Consult local applicable standards for guidance. Additional references include American Petroleum Institute 2003 (Protection Against Ignitions Arising out of Static, Lightning and Stray Currents) or National Fire Protection Agency 77 (Recommended Practice on Static Electricity) or CENELEC CLC/TR 50404 (Electrostatics - Code of practice for the avoidance of hazards due to static electricity).

Static Accumulator: This material is a static accumulator.

STORAGE

The container choice, for example storage vessel, may effect static accumulation and dissipation. Do not store in open or unlabelled containers. Keep away from incompatible materials.

SECTION 8 EXPOSURE CONTROLS / PERSONAL PROTECTION

Exposure limits/standards for materials that can be formed when handling this product: When mists/aerosols can occur the following are recommended: 5 mg/m³ - ACGIH TLV (inhalable fraction), 5 mg/m³ - OSHA PEL.

NOTE: Limits/standards shown for guidance only. Follow applicable regulations.

No biological limits allocated.

ENGINEERING CONTROLS

The level of protection and types of controls necessary will vary depending upon potential exposure conditions. Control measures to consider:

No special requirements under ordinary conditions of use and with adequate ventilation.

PERSONAL PROTECTION

Personal protective equipment selections vary based on potential exposure conditions such as applications, handling practices, concentration and ventilation. Information on the selection of protective equipment for use with this material, as provided below, is based upon intended, normal usage.

Respiratory Protection: If engineering controls do not maintain airborne contaminant concentrations at a level which is adequate to protect worker health, an approved respirator may be appropriate. Respirator selection, use, and maintenance must be in accordance with regulatory requirements, if applicable. Types of respirators to be considered for this material include:

No special requirements under ordinary conditions of use and with adequate ventilation.

Product Name: MOBIL VACTRA OIL HEAVY MEDIUM
Revision Date: 16 Mar 2015
Page 5 of 10

For high airborne concentrations, use an approved supplied-air respirator, operated in positive pressure mode. Supplied air respirators with an escape bottle may be appropriate when oxygen levels are inadequate, gas/vapor warning properties are poor, or if air purifying filter capacity/rating may be exceeded.

Hand Protection: Any specific glove information provided is based on published literature and glove manufacturer data. Glove suitability and breakthrough time will differ depending on the specific use conditions. Contact the glove manufacturer for specific advice on glove selection and breakthrough times for your use conditions. Inspect and replace worn or damaged gloves. The types of gloves to be considered for this material include:

No protection is ordinarily required under normal conditions of use.

Eye Protection: If contact is likely, safety glasses with side shields are recommended.

Skin and Body Protection: Any specific clothing information provided is based on published literature or manufacturer data. The types of clothing to be considered for this material include:

No skin protection is ordinarily required under normal conditions of use. In accordance with good industrial hygiene practices, precautions should be taken to avoid skin contact.

Specific Hygiene Measures: Always observe good personal hygiene measures, such as washing after handling the material and before eating, drinking, and/or smoking. Routinely wash work clothing and protective equipment to remove contaminants. Discard contaminated clothing and footwear that cannot be cleaned. Practice good housekeeping.

ENVIRONMENTAL CONTROLS

Comply with applicable environmental regulations limiting discharge to air, water and soil. Protect the environment by applying appropriate control measures to prevent or limit emissions.

SECTION 9 PHYSICAL AND CHEMICAL PROPERTIES

Note: Physical and chemical properties are provided for safety, health and environmental considerations only and may not fully represent product specifications. Contact the Supplier for additional information.

GENERAL INFORMATION

Physical State: Liquid
Color: Amber
Odor: Characteristic
Odor Threshold: N/D

IMPORTANT HEALTH, SAFETY, AND ENVIRONMENTAL INFORMATION

Relative Density (at 15 °C): 0.882
Flammability (Solid, Gas): N/A
Flash Point [Method]: >204°C (399°F) [ASTM D-92]
Flammable Limits (Approximate volume % in air): LEL: 0.9 UEL: 7.0
Autoignition Temperature: N/D
Boiling Point / Range: > 316°C (600°F)
Decomposition Temperature: N/D
Vapor Density (Air = 1): > 2 at 101 kPa
Vapor Pressure: < 0.013 kPa (0.1 mm Hg) at 20 °C
Evaporation Rate (n-butyl acetate = 1): N/D



Product Name: MOBIL VACTRA OIL HEAVY MEDIUM
 Revision Date: 16 Mar 2015
 Page 6 of 10

pH: N/A
Log Pow (n-Octanol/Water Partition Coefficient): > 3.5
Solubility in Water: Negligible
Viscosity: >68 cSt (68 mm²/sec) at 40 °C
Oxidizing Properties: See Hazards Identification Section.

OTHER INFORMATION

Freezing Point: N/D
Melting Point: N/A
Pour Point: -15°C (5°F)
DMSO Extract (mineral oil only), IP-346: < 3 %wt

SECTION 10 STABILITY AND REACTIVITY

REACTIVITY: See sub-sections below.

STABILITY: Material is stable under normal conditions.

CONDITIONS TO AVOID: Excessive heat. High energy sources of ignition.

MATERIALS TO AVOID: Strong oxidizers

HAZARDOUS DECOMPOSITION PRODUCTS: Material does not decompose at ambient temperatures.

POSSIBILITY OF HAZARDOUS REACTIONS: Hazardous polymerization will not occur.

SECTION 11 TOXICOLOGICAL INFORMATION

INFORMATION ON TOXICOLOGICAL EFFECTS

Hazard Class	Conclusion / Remarks
Inhalation	
Acute Toxicity: No end point data for material.	Minimally Toxic. Based on assessment of the components.
Irritation: No end point data for material.	Negligible hazard at ambient/normal handling temperatures.
Ingestion	
Acute Toxicity: No end point data for material.	Minimally Toxic. Based on assessment of the components.
Skin	
Acute Toxicity: No end point data for material.	Minimally Toxic. Based on assessment of the components.
Skin Corrosion/Irritation: No end point data for material.	Negligible irritation to skin at ambient temperatures. Based on assessment of the components.
Eye	
Serious Eye Damage/Irritation: No end point data for material.	May cause mild, short-lasting discomfort to eyes. Based on assessment of the components.
Sensitization	
Respiratory Sensitization: No end point data for material.	Not expected to be a respiratory sensitizer.
Skin Sensitization: No end point data for material.	Not expected to be a skin sensitizer. Based on assessment of the components.
Aspiration: Data available.	Not expected to be an aspiration hazard. Based on



Product Name: MOBIL VACTRA OIL HEAVY MEDIUM
Revision Date: 16 Mar 2015
Page 7 of 10

	physico-chemical properties of the material.
Germ Cell Mutagenicity: No end point data for material.	Not expected to be a germ cell mutagen. Based on assessment of the components.
Carcinogenicity: No end point data for material.	Not expected to cause cancer. Based on assessment of the components.
Reproductive Toxicity: No end point data for material.	Not expected to be a reproductive toxicant. Based on assessment of the components.
Lactation: No end point data for material.	Not expected to cause harm to breast-fed children.
Specific Target Organ Toxicity (STOT)	
Single Exposure: No end point data for material.	Not expected to cause organ damage from a single exposure.
Repeated Exposure: No end point data for material.	Not expected to cause organ damage from prolonged or repeated exposure. Based on assessment of the components.

OTHER INFORMATION

Contains:

Base oil severely refined: Not carcinogenic in animal studies. Representative material passes IP-346, Modified Ames test, and/or other screening tests. Dermal and inhalation studies showed minimal effects; lung non-specific infiltration of immune cells, oil deposition and minimal granuloma formation. Not sensitizing in test animals.

The following ingredients are cited on the lists below: None.

--REGULATORY LISTS SEARCHED--

1 = NTP CARC
2 = NTP SUS

3 = IARC 1
4 = IARC 2A

5 = IARC 2B
6 = OSHA CARC

SECTION 12

ECOLOGICAL INFORMATION

The information given is based on data available for the material, the components of the material, and similar materials.

ECOTOXICITY

Material -- Not expected to be harmful to aquatic organisms.

MOBILITY

Base oil component -- Low solubility and floats and is expected to migrate from water to the land.
Expected to partition to sediment and wastewater solids.

PERSISTENCE AND DEGRADABILITY

Biodegradation:

Base oil component -- Expected to be inherently biodegradable

BIOACCUMULATION POTENTIAL

Base oil component -- Has the potential to bioaccumulate, however metabolism or physical properties may reduce the bioconcentration or limit bioavailability.



Product Name: MOBIL VACTRA OIL HEAVY MEDIUM
Revision Date: 16 Mar 2015
Page 8 of 10

SECTION 13 DISPOSAL CONSIDERATIONS

Disposal recommendations based on material as supplied. Disposal must be in accordance with current applicable laws and regulations, and material characteristics at time of disposal.

DISPOSAL RECOMMENDATIONS

Product is suitable for burning in an enclosed controlled burner for fuel value or disposal by supervised incineration at very high temperatures to prevent formation of undesirable combustion products. Protect the environment. Dispose of used oil at designated sites. Minimize skin contact. Do not mix used oils with solvents, brake fluids or coolants.

REGULATORY DISPOSAL INFORMATION

RCRA Information: The unused product, in our opinion, is not specifically listed by the EPA as a hazardous waste (40 CFR, Part 261D), nor is it formulated to contain materials which are listed as hazardous wastes. It does not exhibit the hazardous characteristics of ignitability, corrosivity or reactivity and is not formulated with contaminants as determined by the Toxicity Characteristic Leaching Procedure (TCLP). However, used product may be regulated.

Empty Container Warning Empty Container Warning (where applicable): Empty containers may contain residue and can be dangerous. Do not attempt to refill or clean containers without proper instructions. Empty drums should be completely drained and safely stored until appropriately reconditioned or disposed. Empty containers should be taken for recycling, recovery, or disposal through suitably qualified or licensed contractor and in accordance with governmental regulations. **DO NOT PRESSURISE, CUT, WELD, BRAZE, SOLDER, DRILL, GRIND, OR EXPOSE SUCH CONTAINERS TO HEAT, FLAME, SPARKS, STATIC ELECTRICITY, OR OTHER SOURCES OF IGNITION. THEY MAY EXPLODE AND CAUSE INJURY OR DEATH.**

SECTION 14 TRANSPORT INFORMATION

LAND (DOT): Not Regulated for Land Transport

LAND (TDG): Not Regulated for Land Transport

SEA (IMDG): Not Regulated for Sea Transport according to IMDG-Code

Marine Pollutant: No

AIR (IATA): Not Regulated for Air Transport

SECTION 15 REGULATORY INFORMATION



Product Name: MOBIL VACTRA OIL HEAVY MEDIUM
 Revision Date: 16 Mar 2015
 Page 9 of 10

OSHA HAZARD COMMUNICATION STANDARD: This material is not considered hazardous in accordance with OSHA HazCom 2012, 29 CFR 1910.1200.

Listed or exempt from listing/notification on the following chemical inventories: AICS, DSL, IECSC, TSCA

EPCRA SECTION 302: This material contains no extremely hazardous substances.

SARA (311/312) REPORTABLE HAZARD CATEGORIES: None.

SARA (313) TOXIC RELEASE INVENTORY: This material contains no chemicals subject to the supplier notification requirements of the SARA 313 Toxic Release Program.

The following ingredients are cited on the lists below: None.

--REGULATORY LISTS SEARCHED--

1 = ACGIH ALL	6 = TSCA 5a2	11 = CA P65 REPRO	16 = MN RTK
2 = ACGIH A1	7 = TSCA 5e	12 = CA RTK	17 = NJ RTK
3 = ACGIH A2	8 = TSCA 6	13 = IL RTK	18 = PA RTK
4 = OSHA Z	9 = TSCA 12b	14 = LA RTK	19 = RI RTK
5 = TSCA 4	10 = CA P65 CARC	15 = MI 293	

Code key: CARC=Carcinogen; REPRO=Reproductive

SECTION 16	OTHER INFORMATION
-------------------	--------------------------

N/D = Not determined, N/A = Not applicable

KEY TO THE H-CODES CONTAINED IN SECTION 3 OF THIS DOCUMENT (for information only):

- H315: Causes skin irritation; Skin Corr/Irritation, Cat 2
- H319(2A): Causes serious eye irritation; Serious Eye Damage/Irr, Cat 2A
- H400: Very toxic to aquatic life; Acute Env Tox, Cat 1
- H410: Very toxic to aquatic life with long lasting effects; Chronic Env Tox, Cat 1

THIS SAFETY DATA SHEET CONTAINS THE FOLLOWING REVISIONS:

Updates made in accordance with implementation of GHS requirements.

 The information and recommendations contained herein are, to the best of ExxonMobil's knowledge and belief, accurate and reliable as of the date issued. You can contact ExxonMobil to insure that this document is the most current available from ExxonMobil. The information and recommendations are offered for the user's consideration and examination. It is the user's responsibility to satisfy itself that the product is suitable for the intended use. If buyer repackages this product, it is the user's responsibility to insure proper health, safety and other necessary information is included with and/or on the container. Appropriate warnings and safe-handling procedures should be provided to



Product Name: MOBIL VACTRA OIL HEAVY MEDIUM
Revision Date: 16 Mar 2015
Page 10 of 10

handlers and users. Alteration of this document is strictly prohibited. Except to the extent required by law, re-publication or retransmission of this document, in whole or in part, is not permitted. The term, "ExxonMobil" is used for convenience, and may include any one or more of ExxonMobil Chemical Company, Exxon Mobil Corporation, or any affiliates in which they directly or indirectly hold any interest.

Internal Use Only

MHC: 0B, 0B, 0, 0, 0, 0

PPEC: A

DGN: 2006644XUS (1017266)

Copyright 2002 Exxon Mobil Corporation, All rights reserved

SAF-T-LOK

International Corporation

Material Safety Data Sheet

SAF-T-EZE MOLY GRADE ANTI-SEIZE

Issue Date: 10/30/14

SECTION I - PRODUCT AND COMPANY INFORMATION

Product Name: MOLY GRADE ANTI-SEIZE
Product Type: Lubricating Grease
Part Numbers: **80855, 80837, 80822, 80878, 80853, 6V-4876**
Hazard Rating: Health: 1 Fire: 1 Reactivity: 0

Company Identification: SAF-T-LOK International Corporation
300 EISENHOWER LANE NORTH
LOMBARD, IL 60148

Contact: Chris Michaels
Telephone/ Fax: (630) 495-2001
Emergency Phone (24 Hour): (703) 527-3887
Chemtrec (24 Hour): (800) 424-9300, (703) 527-3887
Preparer: Ind. Hygiene Department
Internet: www.saftlok.com

Product Class: Mixture
DOT Hazard Class: N/A
Shipping Name: Unrestricted

SECTION II - INGREDIENT AND HAZARD INFORMATION

Components	CAS Number	Percent
Graphite	7782-42-5	20 - 30
Hydrotreated Heavy Napthenic Distillate	64742-52-5	40 - 50
Molybdenum Disulfide	1317-33-5	20 - 30

SECTION III - HAZARD IDENTIFICATION AND EMERGENCY OVERVIEW

EMERGENCY OVERVIEW

Physical appearance:	Paste	<u>HMSI</u>	
Physical color:	Black	Health:	1
Odor:	Mild / Inoffensive	Flammability:	1
		Reactivity:	0
		Personal Protection:	B

WARNING; MAY CAUSE: EYE IRRITATION
SKIN IRRITATION
RESPIRATORY TRACT IRRITATION
MAY IRRITATE EXISTING ALLERGIC SKIN CONDITIONS

Relative routes of entry: Skin, Inhalation, Eyes, Ingestion

Skin Contact: Usually no effect, however, as with any chemical, prolonged, excessive, or repeated exposure may cause mild to moderate skin irritation, exhibited by redness, drying and cracking of unprotected skin.

Eye Contact: May irritate with slight pain and redness.

Respiratory/ Inhalation: Usually none, however, as with any chemical product, some irritation may occur.

Ingestion: Amounts transferred to mouth by fingers, etc, during normal operation should not cause injury.

Medical conditions generally aggravated by exposure: None known, however any chemical product may enhance allergies already present in certain individuals.

This product does not require exceptional labeling due to the evaluation procedure of the "General Classification guideline for preparations of the EU".

SECTION IV – FIRST AID INSTRUCTIONS

Skin Contact: Remove contaminated clothing. Wash affected area with soap and rinse with plenty of water. Get medical attention if symptoms occur. Wash clothing before reuse.

Eye Contact: Flush with water for at least 15 minutes holding eyelid open. Get medical attention if symptoms persist.

Respiratory / Inhalation: Remove to fresh air, if symptoms develop get medical attention.

Ingestion: Do not induce vomiting. Obtain medical attention if symptoms develop.

SECTION V – FIRE FIGHTING INSTRUCTIONS

Flash Point:	360°F (C.O.C.)
Unusual Fire and Explosion Hazards:	None
Flammable Limits:	LEL: N/A, UEL: N/A
Extinguishing Media:	Carbon Dioxide, Foam, Dry Chemicals
Fire Fighting Procedures:	Air mask and procedures for fighting chemical fires. Do not inhale gases.

SECTION VI -ACCIDENTAL RELEASE MEASURES

Special Precautions: None known. Follow general precautions shown below.

Environmental precautions: Prevent material from entering floor drains, sewers, or any bodies of water.

Clean up methods: Scoop up into waste container or soak up with absorbent material. Store in a closed container until disposal. Dispose of material according to regulations.

SECTION VII - HANDLING AND STORAGE

Handling: No special precautions necessary if used properly. Avoid contact with eyes, skin, and clothing. Avoid breathing vapors. Wash hands thoroughly at mealtime and end of shift.

Storage: Isolated storage facility/ warehouse not required. Store in a cool, dry location (60-90°F) in a well-ventilated area in original container. Keep container tightly closed when not in use.

Personal Protection: Wear personal protective equipment as outlined in Section VIII of this MSDS.

SECTION VIII – EXPOSURE CONTROLS AND PERSONAL PROTECTION

Respiratory Protection: No respiratory protection required, but normal good ventilation is recommended. Forced ventilation may be required if concentrations exceed normal use exposure.

Skin Protection: Not required, but if desired, use impermeable gloves (neoprene, butyl rubber, natural rubber), as necessary to avoid skin contact, as well as proper clothing or plastic apron. Wash hands before eating, drinking, or using restroom.

Eye Protection: Not required if application method is proper. Avoid contact with eyes.

Eye Washes: Eye wash stations should be located within 100 feet or 10 second walk of the work area.

SECTION IX - PHYSICAL AND CHEMICAL PROPERTIES

Physical state: Paste
Color: Black
Odor: Mild/ Inoffensive
Boiling Point: 600°F (316°C)
Melting Point: Not determined
Flash Point: 360°F
Self-inflammability: Is not self-igniting
Explosion danger: Not explosive
Specific Gravity: 1.4
Vapor Density (Air = 1): N/D
Vapor Pressure (mm Hg.): < 0.1 @70°F
pH: Not determined
Evaporation Rate: Not determined
Solubility in Water: Insoluble
VOC (Organic solvents): 0.1%
Percent Solids: 50

SECTION X –STABILITY AND REACTIVITY

Stability: Stable
Hazardous Polymerization: Will not occur
Hazardous decomposition byproducts: None if used and stored according to specifications
Conditions to avoid: Strong oxidizing agents

SECTION XI – TOXICOLOGICAL INFORMATION

No harmful effects have been determined if product is used and handled according to specifications.

This product is not subject to classification according to the calculation method of the General EC Classification Guidelines for Preparations.

Sensitization: None known
Eye Irritant: Not determined
Skin Irritant: Not determined
Carcinogen: No

SECTION XII – ECOLOGICAL DATA

Water Hazard: Do not allow entry into drains or surface water
Class 2 per German Regulation

SECTION XIII – DISPOSAL CONSIDERATIONS

Recommended method of disposal: Small quantities can be disposed with normal household waste.
Disposal must be made according to official regulations.

EPA Hazardous Waste Number; Not an RCRA hazardous waste.

SECTION XIV – SHIPPING AND TRANSPORTATION INFORMATION

U.S. Department of Transportation Ground (49 CFR

Proper Shipping Name: Unrestricted
Hazard Class or Division: None
Identification Number: None
Packing Group: None

International Air Transportation (OCAO/IATA):

Proper Shipping Name: Unrestricted
Hazard Class or Division: None
Identification Number: None
Packing Group: None

Water Transportation (IMO/IMDG):

Proper Shipping Name: Environmentally hazardous substance, liquid, N.O. S.
Hazard Class or Division: IMDG Class 9
Identification Number: None
Packing Group: None
Marine Pollutant: Yes

ADR/RID-GGVS/E Class (cross border) Unrestricted

SECTION XV – REGULATORY INFORMATIONUnited States Regulatory Information

TSCA 8 (b) Inventory Status: All components are listed or are exempt from listing on the Toxic Substances Control Act Inventory

Canada Regulatory Information

CEPA DSL/NDSL Status: All components are listed on or are exempt from listing on the Domestic Substances List.

SECTION XVI – OTHER INFORMATION

Revision date: 10/30/14
By: Human Resource Department

DISCLAIMER: The information on this material safety data sheet represents our current data and best opinion as to the proper use in handling of this product under normal conditions. Any use of the product which is not in conformance with this data sheet or which involves using the product in combination with any other product or any other process is the responsibility of the user. SAF-T-LOK International Corporation specifically disclaims all warranties, express or implied, including warranties of merchantability and fitness for a particular purpose, arising from sale or use of SAF-T-LOK International Corporation products.

Product Name: Nook Industries E-900L Liquid
(Part number NLU-1004)
Revision Date: 23 Sept 2013
Page 1 of 7



MATERIAL SAFETY DATA SHEET

SECTION 1 PRODUCT AND COMPANY IDENTIFICATION

PRODUCT

Product Name: Nook Industries E-900L Ball Screw Lubricant Liquid
Product Description: Synthetic Base Stocks and Additives
Product Code: 202050401020, 494237-00, 971870
Intended Use: Ball screw lubrication

COMPANY IDENTIFICATION

Supplier: **NOOK INDUSTRIES**
4950 EAST 49th STREET
CLEVELAND, OH 44125

24 Hour Health Emergency 800-255-3924
MSDS Requests 800-321-7800
MSDS Internet Address <http://www.nookindustries.com/r/msds>

SECTION 2 COMPOSITION / INFORMATION ON INGREDIENTS

REPORTABLE HAZARDOUS SUBSTANCE(S) OR COMPLEX SUBSTANCE(S)

NAME	CAS#	CONCENTRATION*
1-NAPHTHYLAMINE, N-PHENYL-	90-30-2	1%

* All concentrations are percent by weight unless material is a gas. Gas concentrations are in percent by volume.

SECTION 3 HAZARDS IDENTIFICATION

This material is not considered to be hazardous according to regulatory guidelines (see (MSDS Section 15)).

POTENTIAL HEALTH EFFECTS

Excessive exposure may result in eye, skin, or respiratory irritation. This product is not expected to produce adverse health effects under normal conditions of use and with appropriate personal hygiene practices. Product may decompose at elevated temperatures or under fire conditions and give off irritating and/or harmful (carbon monoxide) gases/vapors/fumes. Symptoms from acute exposure to these decomposition products in confined spaces may include headache, nausea, eye, nose, and throat irritation. High-pressure injection under skin may cause serious damage.

NFPA HAZARD ID:	HEALTH: 1	FLAMMABILITY: 1	REACTIVITY: 0
HMIS Hazard ID:	Health: 1	Flammability: 1	Reactivity: 0

NOTE: This material should not be used for any other purpose than the intended use in Section 1 without expert advice. Health studies have shown that chemical exposure may cause potential human health risks which may vary from person to person.

Product Name: Nook Industries E-900L Liquid
(Part number NLU-1004)
Revision Date: 23 Sept 2013
Page 2 of 7



SECTION 4 FIRST AID MEASURES

INHALATION

Remove from further exposure. For those providing assistance, avoid exposure to yourself or others. Use adequate respiratory protection. If respiratory irritation, dizziness, nausea, or unconsciousness occurs, seek immediate medical assistance. If breathing has stopped, assist ventilation with a mechanical device or use mouth-to-mouth resuscitation.

SKIN CONTACT

Wash contact areas with soap and water. If product is injected into or under the skin, or into any part of the body, regardless of the appearance of the wound or its size, the individual should be evaluated immediately by a physician as a surgical emergency. Even though initial symptoms from high pressure injection may be minimal or absent, early surgical treatment within the first few hours may significantly reduce the ultimate extent of injury.

EYE CONTACT

Flush thoroughly with water. If irritation occurs, get medical assistance.

INGESTION

Seek immediate medical attention.

SECTION 5 FIRE FIGHTING MEASURES

EXTINGUISHING MEDIA

Appropriate Extinguishing Media: Use water fog, foam, dry chemical or carbon dioxide (CO₂) to extinguish flames.

Inappropriate Extinguishing Media: Straight Streams of Water

FIRE FIGHTING

Fire Fighting Instructions: Evacuate area. Prevent runoff from fire control or dilution from entering streams, sewers, or drinking water supply. Firefighters should use standard protective equipment and in enclosed spaces, self-contained breathing apparatus (SCBA). Use water spray to cool fire exposed surfaces and to protect personnel.

Hazardous Combustion Products: Aldehydes, Smoke, Fume, Oxides of carbon, Sulfur oxides, Incomplete combustion products, Trimethylol propane phosphate

FLAMMABILITY PROPERTIES

Flash Point [Method]: 210C (410F) [ASTM D-92]
Flammable Limits (Approx vol % in air): LEL: N/D UEL: N/D
Autoignition Temperature: N/D



SECTION 6 ACCIDENTAL RELEASE MEASURES

NOTIFICATION PROCEDURES

In the event of a spill or accidental release, notify relevant authorities in accordance with all applicable regulations. US regulations require reporting releases of this material to the environment which exceed the applicable reportable quantity or oil spills which could reach any waterway including intermittent dry creeks. The National Response Center can be reached at (800)424-8802.

SPILL MANAGEMENT

Land Spill: Stop leak if you can do it without risk. Recover by pumping or with suitable absorbent.

Water Spill: Stop leak if you can do it without risk. Confine the spill immediately with booms. Warn other shipping. Remove from the surface by skimming or with suitable absorbents. Seek the advice of a specialist before using dispersants.

Water spill and land spill recommendations are based on the most likely spill scenario for this material; however, geographic conditions, wind, temperature, (and in the case of a water spill) wave and current direction and speed may greatly influence the appropriate action to be taken. For this reason, local experts should be consulted. Note: Local regulations may prescribe or limit action to be taken.

ENVIRONMENTAL PRECAUTIONS

Large Spills: Dike far ahead of liquid spill for later recovery and disposal. Prevent entry into waterways, sewers, basements or confined areas.

SECTION 7 HANDLING AND STORAGE

HANDLING

It has been determined that during fires neurotoxic trimethylol propane phosphate may be formed, which when inhaled may impair central nervous system function. In addition, thermally decomposed (and cooled) residues may be neurotoxic. Prevent small spills and leakage to avoid slip hazard.

Static Accumulator: This material is a static accumulator.

STORAGE

Do not store in open or unlabelled containers.

SECTION 8 EXPOSURE CONTROLS / PERSONAL PROTECTION

NOTE: Limits/standards shown for guidance only. Follow applicable regulations.

ENGINEERING CONTROLS

The level of protection and types of controls necessary will vary depending upon potential exposure conditions. Control measures to consider:

No special requirements under ordinary conditions of use and with adequate ventilation.

PERSONAL PROTECTION

Personal protective equipment selections vary based on potential exposure conditions such as applications, handling practices, concentration and ventilation. Information on the selection of protective equipment for use with this material, as provided below, is based upon intended, normal usage.

Product Name: Nook Industries E-900L Liquid
(Part number NLU-1004)
Revision Date: 23 Sept 2013
Page 4 of 7



Respiratory Protection: If engineering controls do not maintain airborne contaminant concentrations at a level which is adequate to protect worker health, an approved respirator may be appropriate. Respirator selection, use, and maintenance must be in accordance with regulatory requirements, if applicable. Types of respirators to be considered for this material include:

No special requirements under ordinary conditions of use and with adequate ventilation.

For high airborne concentrations, use an approved supplied-air respirator, operated in positive pressure mode. Supplied air respirators with an escape bottle may be appropriate when oxygen levels are inadequate, gas/vapor warning properties are poor, or if air purifying filter capacity/rating may be exceeded.

Hand Protection: Any specific glove information provided is based on published literature and glove manufacturer data. Glove suitability and breakthrough time will differ depending on the specific use conditions. Contact the glove manufacturer for specific advice on glove selection and breakthrough times for your use conditions. Inspect and replace worn or damaged gloves. The types of gloves to be considered for this material include:

No protection is ordinarily required under normal conditions of use.

Eye Protection: If contact is likely, safety glasses with side shields are recommended.

Skin and Body Protection: Any specific clothing information provided is based on published literature or manufacturer data. The types of clothing to be considered for this material include:

No skin protection is ordinarily required under normal conditions of use. In accordance with good industrial hygiene practices, precautions should be taken to avoid skin contact.

Specific Hygiene Measures: Always observe good personal hygiene measures, such as washing after handling the material and before eating, drinking, and/or smoking. Routinely wash work clothing and protective equipment to remove contaminants. Discard contaminated clothing and footwear that cannot be cleaned. Practice good housekeeping.

ENVIRONMENTAL CONTROLS

See Sections 6, 7, 12, 13.

SECTION 9 PHYSICAL AND CHEMICAL PROPERTIES

Typical physical and chemical properties are given below. Consult the Supplier in Section 1 for additional data.

GENERAL INFORMATION

Physical State:	Liquid
Color:	Amber
Odor:	Characteristic
Odor Threshold:	N/D

IMPORTANT HEALTH, SAFETY, AND ENVIRONMENTAL INFORMATION

Relative Density (at 15 C):	0.96
Flash Point [Method]:	210C (410F) [ASTM D-92]
Flammable Limits (Approx vol % in air):	LEL: N/D UEL: N/D
Autoignition Temperature:	N/D
Boiling Point / Range:	> 316C (600F)
Vapor Density (Air = 1):	N/D
Vapor Pressure:	< 0.013 kPa (0.1 mm Hg) at 20 C
Evaporation Rate (n-butyl acetate = 1):	N/D
pH:	N/A

Product Name: Nook Industries E-900L Liquid
(Part number NLU-1004)
Revision Date: 23 Sept 2013
Page 5 of 7



Log Pow (n-Octanol/Water Partition Coefficient): N/A
Solubility in Water: Negligible
Viscosity: 13.3 cSt (13.3 mm²/sec) at 40 C | 3 cSt (3 mm²/sec) at 100C
Oxidizing Properties: See Sections 3, 15, 16.

OTHER INFORMATION

Freezing Point: N/D
Melting Point: N/A
Pour Point: -62°C (-80°F)

SECTION 10 STABILITY AND REACTIVITY

Stability: material is stable under normal conditions.
Conditions To Avoid: excessive heat. High energy sources of ignition.
Materials To Avoid: Strong oxidizers
Hazardous Decomposition Products: material does not decompose at ambient temperatures.
Hazardous Polymerization: will not occur.

SECTION 11 TOXICOLOGICAL INFORMATION

ACUTE TOXICITY

ROUTE OF EXPOSURE	CONCLUSION / REMARKS
Inhalation	
Toxicity: No end point data.	Not determined.
Irritation: No end point data.	Negligible hazard at ambient/normal handling temperatures. Based on assessment of the components.
Ingestion	
Toxicity: No end point data.	Minimally Toxic. Based on assessment of the components.
Skin	
Toxicity: No end point data.	Minimally Toxic. Based on assessment of the components.
Irritation: No end point data.	Negligible irritation to skin at ambient temperatures. Based on assessment of the components.
Eye	
Irritation: No end point data.	May cause mild, short-lasting discomfort to eyes. Based on assessment of the components.

CHRONIC/OTHER EFFECTS

Contains:
N-phenyl-1-naphthylamine: A single oral overexposure may lead to signs of cyanosis, including headache, shallow respiration, dizziness, confusion, fall in blood pressure, convulsions, coma, jaundice.

Product Name: Nook Industries E-900L Liquid
(Part number NLU-1004)
Revision Date: 23 Sept 2013
Page 6 of 7



Anemia may occur later. Repeated exposure in laboratory animals caused liver and kidney damage and depression of bone marrow activity. Hematuria may occur due to bladder and kidney irritation. Genotoxic in vitro.

Phenyl-alpha-naphthylamine (PAN): Undiluted PAN is a skin sensitizer. Human testing with lubricants containing 1.0% PAN caused no reactions indicative of sensitization.

Additional information is available by request.

The following ingredients are cited on the lists below: None.

--REGULATORY LISTS SEARCHED--		
1 = NTP CARC	3 = IARC 1	5 = IARC 2B
2 = NTP SUS	4 = IARC 2A	6 = OSHA CARC

SECTION 12 ECOLOGICAL INFORMATION

The information given is based on data available for the material, the components of the material, and similar materials.

ECOTOXICITY

Material – Not expected to be harmful to aquatic organisms.

Material – Not expected to demonstrate chronic toxicity to aquatic organisms.

SECTION 13 DISPOSAL CONSIDERATIONS

Disposal recommendations based on material as supplied. Disposal must be in accordance with current applicable laws and regulations, and material characteristics at time of disposal.

DISPOSAL RECOMMENDATIONS

Dispose of waste at an appropriate treatment & disposal facility in accordance with applicable laws and regulations, and product characteristics at time of disposal.

REGULATORY DISPOSAL INFORMATION

RCRA Information: The unused product, in our opinion, is not specifically listed by the EPA as a hazardous waste (40 CFR, Part 261D), nor is it formulated to contain materials which are listed as hazardous wastes. It does not exhibit the hazardous characteristics of ignitability, corrosivity or reactivity and is not formulated with contaminants as determined by the Toxicity Characteristic Leaching Procedure (TCLP). However, used product may be regulated.

Empty Container Warning Empty Container Warning (where applicable): Empty containers may contain residue and can be dangerous. Do not attempt to refill or clean containers without proper instructions. Empty drums should be completely drained and safely stored until appropriately reconditioned or disposed. Empty containers should be taken for recycling, recovery, or disposal through suitably qualified or licensed contractor and in accordance with governmental regulations. **DO NOT PRESSURISE, CUT, WELD, BRAZE, SOLDER, DRILL, GRIND, OR EXPOSE SUCH CONTAINERS TO HEAT, FLAME, SPARKS, STATIC ELECTRICITY, OR OTHER SOURCES OF IGNITION. THEY MAY EXPLODE AND CAUSE INJURY OR DEATH.**

Product Name: Nook Industries E-900L Liquid
(Part number NLU-1004)
Revision Date: 23 Sept 2013
Page 7 of 7



SECTION 14 TRANSPORT INFORMATION

LAND (DOT) : Not Regulated for Land Transport
LAND (TDG) : Not Regulated for Land Transport
SEA (IMDG) : Not Regulated for Sea Transport according to IMDG-Code
AIR (IATA) : Not Regulated for Air Transport

SECTION 15 REGULATORY INFORMATION

OSHA HAZARD COMMUNICATION STANDARD: When used for its intended purposes, this material is not classified as hazardous in accordance with OSHA 29 CFR 1910.1200.

NATIONAL CHEMICAL INVENTORY LISTING: PICCS, AICS, KECI, TSCA, EINECS

EPCRA: This material contains no extremely hazardous substances.

SARA (311/312) REPORTABLE HAZARD CATEGORIES: None.

SARA (313) TOXIC RELEASE INVENTORY: This material contains no chemicals subject to the supplier notification requirements of the SARA 313 Toxic Release Program.

The Following Ingredients are Cited on the Lists Below:

CHEMICAL NAME	CAS NUMBER	LIST CITATIONS
Diphenylamine	122-39-4	5

--REGULATORY LISTS SEARCHED--			
1 = ACGIH ALL	6 = TSCA 5a2	11 = CA P65 REPRO	16 = MN RTK
2 = ACGIH A1	7 = TSCA 5e	12 = CA RTK	17 = NJ RTK
3 = ACGIH A2	8 = TSCA 6	13 = IL RTK	18 = PA RTK
4 = OSHA Z	9 = TSCA 12b	14 = LA RTK	19 = RI RTK
5 = TSCA 4	10 = CA P65 CARC	15 = MI 293	

Code key: CARC=Carcinogen; REPRO=Reproductive

SECTION 16 OTHER INFORMATION

N/D = Not determined, N/A = Not applicable

###

The information and recommendations contained herein are, to the best of Nook Industries' knowledge and belief, accurate and reliable as of the date issued. You can contact Nook Industries to insure that this document is the most current available from Nook Industries. The information and recommendations are offered for the user's consideration and examination. It is the user's responsibility to satisfy itself that the product is suitable for the intended use. If buyer repackages this product, it is the user's responsibility to insure proper health, safety and other necessary information is included with and/or on the container. Appropriate warnings and safe-handling procedures should be provided to handlers and users. Alteration of this document is strictly prohibited. Except to the extent required by law, re-publication or retransmission of this document, in whole or in part, is not permitted.

Product Name: Nook Industries PAG-1 Grease
(Part number NLU-1001)
Revision Date: 23 Sept 2013
Page 1 of 8



MATERIAL SAFETY DATA SHEET

SECTION 1 PRODUCT AND COMPANY IDENTIFICATION

PRODUCT

Product Name: Omniguard
MSDS Number: 778589
Intended Use: Lubricating Grease

COMPANY IDENTIFICATION

Supplier Nook Industries
 4950 East 49th Street
 Cleveland, Oh 44125

24 Health Emergency: Chemtrec: 800-424-9300 (24 Hours)
MSDS Requests: 800-321-7800
MSDS Internet Address <http://www.nookindustries.com/r/msds>

SECTION 2 HAZARDS IDENTIFICATION

EMERGENCY OVERVIEW

Appearance: Tan
Physical Form: Semi-Solid
Odor: Petroleum

POTENTIAL HEALTH EFFECTS

Eye: Eye irritant. Contact may cause stinging, watering, redness, and swelling.
Skin: Contact may cause mild skin irritation including redness and a burning sensation. Repeated exposure may cause skin dryness or cracking. No information available on skin absorption.
 Inhalation (Breathing): No information available on acute toxicity. Inhalation is not an expected route of exposure.
Ingestion (Swallowing): Low degree of toxicity by ingestion.
Signs and Symptoms: Inhalation of oil mists or vapors generated at elevated temperatures may cause respiratory irritation. Accidental ingestion can result in minor irritation of the digestive tract, nausea and diarrhea.
Pre-Existing Medical Conditions: Conditions which may be aggravated by exposure include eye disorders and skin disorders.

See Section 11 for additional Toxicity Information.

SECTION 3 COMPOSITION / INFORMATION ON INGREDIENTS

COMPONENT	CASRN	CONCENTRATION ¹
Lubricant Base Oil (Petroleum)	VARIOUS	50 - 80
Additives	PROPRIETARY	15 - 40
Calcium Dodecylbenzenesulfonate	26264-06-2	1 - 3

¹ All concentrations are percent by weight unless ingredient is a gas. Gas concentrations are in percent by volume.



SECTION 4 FIRST AID MEASURES

Eye Contact: For direct contact, remove contact lenses if present and easy to do. Immediately hold eyelids apart and flush the affected eye(s) with clean water for at least 15 minutes. Seek immediate medical attention.

Skin Contact: Remove contaminated shoes and clothing and cleanse affected area(s) thoroughly by washing with mild soap and water or a waterless hand cleaner. If irritation or redness develops and persists, seek medical attention. If product is injected into or under the skin, or into any part of the body, regardless of the appearance of the wound or its size, the individual should be evaluated immediately by a physician. (see Note to Physician)

Inhalation (Breathing): If respiratory symptoms develop, move victim away from source of exposure and into fresh air in a position comfortable for breathing. If symptoms persist, seek medical attention.

Ingestion (Swallowing): First aid is not normally required; however, if swallowed and symptoms develop, seek medical attention.

Notes to Physician: High-pressure hydrocarbon injection injuries may produce substantial necrosis of underlying tissue despite an innocuous appearing external wound. These injuries often require extensive emergency surgical debridement and all injuries should be evaluated by a specialist in order to assess the extent of injury. Early surgical treatment within the first few hours may significantly reduce the ultimate extent of injury.

SECTION 5 FIRE-FIGHTING MEASURES

NFPA 704 Hazard Class

Health:	1
Flammability:	1
Instability:	0

(0-Minimal, 1-Slight, 2-Moderate, 3-Serious, 4-Severe)

Unusual Fire & Explosion Hazards: This material may burn, but will not ignite readily. If container is not properly cooled, it can rupture in the heat of a fire.

Extinguishing Media: Dry chemical, carbon dioxide, foam, or water spray is recommended. Water or foam may cause frothing of materials heated above 212°F / 100°C. Carbon dioxide can displace oxygen. Use caution when applying carbon dioxide in confined spaces. Simultaneous use of foam and water on the same surface is to be avoided as water destroys the foam.

Fire Fighting Instructions: For fires beyond the initial stage, emergency responders in the immediate hazard area should wear protective clothing. When the potential chemical hazard is unknown, in enclosed or confined spaces, a self contained breathing apparatus should be worn. In addition, wear other appropriate protective equipment as conditions warrant (see Section 8).

Isolate immediate hazard area and keep unauthorized personnel out. Stop spill/release if it can be done safely. Move undamaged containers from immediate hazard area if it can be done safely. Water spray may be useful in minimizing or dispersing vapors and to protect personnel. Cool equipment exposed to fire with water, if it can be done safely. Avoid spreading burning liquid with water used for cooling purposes.

Hazardous Combustion Products: Combustion may yield smoke, carbon monoxide, and other products of incomplete combustion.

Oxides of sulfur, nitrogen or phosphorus may also be formed.

See Section 9 for Flammable Properties including Flash Point and Flammable (Explosive) Limits

Product Name: Nook Industries PAG-1 Grease
(Part number NLU-1001)
Revision Date: 23 Sept 2013
Page 3 of 8



SECTION 6 ACCIDENTAL RELEASE MEASURES

Personal Precautions: This material may burn, but will not ignite readily. Keep all sources of ignition away from spill/release. Stay upwind and away from spill/release. Avoid direct contact with material. For large spillages, notify persons down wind of the spill/release, isolate immediate hazard area and keep unauthorized personnel out. Wear appropriate protective equipment, including respiratory protection, as conditions warrant (see Section 8). See Sections 2 and 7 for additional information on hazards and precautionary measures.

Environmental Precautions: If spill/release in excess of EPA reportable quantity (see Section 15) is made into the environment, immediately notify the National Response Center (phone number 800-424-8802). Stop spill/release if it can be done safely. Prevent spilled material from entering sewers, storm drains, other unauthorized drainage systems, and natural waterways. Use water sparingly to minimize environmental contamination and reduce disposal requirements. If spill occurs on water notify appropriate authorities and advise shipping of any hazard. Spills into or upon navigable waters, the contiguous zone, or adjoining shorelines that cause a sheen or discoloration on the surface of the water, may require notification of the National Response Center (phone number 800-424-8802).

Methods for Containment and Clean-Up: Notify relevant authorities in accordance with all applicable regulations. Immediate cleanup of any spill is recommended. Dike far ahead of spill for later recovery or disposal. Absorb spill with inert material such as sand or vermiculite, and place in suitable container for disposal. If spilled on water remove with appropriate methods (e.g. skimming, booms or absorbents). In case of soil contamination, remove contaminated soil for remediation or disposal, in accordance with local regulations.

SECTION 7 HANDLING AND STORAGE

Precautions for safe handling: Keep away from flames and hot surfaces. Wear eye/face protection. Wash thoroughly after handling.

Use good personal hygiene practices and wear appropriate personal protective equipment.

High pressure injection of hydrocarbon fuels, hydraulic oils or greases under the skin may have serious consequences even though no symptoms or injury may be apparent. This can happen accidentally when using high pressure equipment such as high pressure grease guns, fuel injection apparatus or from pinhole leaks in tubing of high pressure hydraulic oil equipment.

Do not enter confined spaces such as tanks or pits without following proper entry procedures such as ASTM D-4276 and 29CFR 1910.146. Do not wear contaminated clothing or shoes.

Conditions for safe storage: Keep container(s) tightly closed and properly labeled. Use and store this material in cool, dry, well-ventilated area away from heat and all sources of ignition. Store only in approved containers. Keep away from any incompatible material (see Section 10). Protect container(s) against physical damage.

"Empty" containers retain residue and may be dangerous. Do not pressurize, cut, weld, braze, solder, drill, grind, or expose such containers to heat, flame, sparks, or other sources of ignition. They may explode and cause injury or death. "Empty" drums should be completely drained, properly bunged, and promptly shipped to the supplier or a drum reconditioner. All containers should be disposed of in an environmentally safe manner and in accordance with governmental regulations. Before working on or in tanks which contain or have contained this material, refer to OSHA regulations, ANSI Z49.1, and other references pertaining to cleaning, repairing, welding, or other contemplated operations.



SECTION 8 EXPOSURE CONTROLS / PERSONAL PROTECTION

COMPONENT	US-ACGIH	OSHA	OTHER
Lubricant Base Oil (Petroleum)	TWA: 5mg/m ³ STEL: 10 mg/m ³ as Oil Mist, if generated	TWA: 5 mg/m ³ as Oil Mist, if generated	---

NOTE: State, local or other agencies or advisory groups may have established more stringent limits. Consult an industrial hygienist or similar professional, or your local agencies, for further information.

Engineering controls: If current ventilation practices are not adequate to maintain airborne concentrations below the established exposure limits, additional engineering controls may be required.

Eye/Face Protection: The use of eye protection that meets or exceeds ANSI Z.87.1 is recommended to protect against potential eye contact, irritation, or injury. Depending on conditions of use, a face shield may be necessary.

Skin/Hand Protection: The use of gloves impervious to the specific material handled is advised to prevent skin contact. Users should check with manufacturers to confirm the breakthrough performance of their products. Suggested protective materials: Nitrile

Respiratory Protection: Respiratory protection is not normally required under intended conditions of use. Emergencies or conditions that could result in significant airborne exposures may require the use of NIOSH approved respiratory protection. An industrial hygienist or other appropriate health and safety professional should be consulted for specific guidance under these situations.

Other Protective Equipment: Eye wash and quick-drench shower facilities should be available in the work area. Thoroughly clean shoes and wash contaminated clothing before reuse.

Suggestions provided in this section for exposure control and specific types of protective equipment are based on readily available information. Users should consult with the specific manufacturer to confirm the performance of their protective equipment. Specific situations may require consultation with industrial hygiene, safety, or engineering professionals.

SECTION 9 PHYSICAL AND CHEMICAL PROPERTIES

NOTE: Unless otherwise stated, values are determined at 20°C (68°F) and 760 mm Hg (1 atm). Data represent typical values and are not intended to be specifications.

Appearance:	Tan
Physical Form:	Semi-Solid
Odor:	Petroleum
Odor Threshold:	No data
pH:	Not applicable
Vapor Pressure:	<0.1 mm Hg
Vapor Density (air=1):	> 5
Initial Boiling Point/Range:	No data
Melting/Freezing Point:	No data
Solubility in Water:	Insoluble
Solubility in Other Solvents:	Soluble
Partition Coefficient (n-octanol/water) (Kow):	No data
Specific Gravity (water=1):	0.9943 @ 60°F (15.6°C)
Bulk Density:	8.29 lbs/gal

Product Name: Nook Industries PAG-1 Grease
(Part number NLU-1001)
Revision Date: 23 Sept 2013
Page 5 of 8



Evaporation Rate (nBuAc=1):	<1
Flash Point:	464°F / 240°C
Test Method:	Cleveland Open Cup (COC), ASTM D92
Lower Explosive Limits (vol % in air):	No data
Upper Explosive Limits (vol % in air):	No data
Auto-ignition Temperature:	No data

SECTION 10 STABILITY AND REACTIVITY

Stability: Stable under normal ambient and anticipated conditions of use.

Conditions to Avoid: Extended exposure to high temperatures can cause decomposition. Avoid all possible sources of ignition.

Materials to Avoid (Incompatible Materials): Avoid contact with strong oxidizing agents and strong reducing agents.

Hazardous Decomposition Products: Not anticipated under normal conditions of use.

Hazardous Polymerization: Not known to occur.

SECTION 11 TOXICOLOGICAL INFORMATION

CHRONIC TOXICITY:

Lubricant Base Oil (Petroleum)

Carcinogenicity: The petroleum base oils contained in this product have been highly refined by a variety of processes including severe hydrocracking/hydroprocessing to reduce aromatics and improve performance characteristics. All of the oils meet the IP-346 criteria of less than 3 percent PAH's and are not considered carcinogens by NTP, IARC, or OSHA.

ACUTE TOXICITY:

COMPONENT	ORAL LD50	DERMAL LD50	INHALATION LC50
Lubricant Base Oil (Petroleum)	> 5 g/kg	> 2 g/kg	> 5 mg/L
Calcium Dodecylbenzenesulfonate	1,300 mg/kg	No data	No data

SECTION 12 ECOLOGICAL INFORMATION

Ecotoxicity: Experimental studies show that acute aquatic toxicity values are greater than 1000 mg/l. These values are consistent with the predicted aquatic toxicity of these substances based on their hydrocarbon compositions. However, there is insufficient information available on the toxicity of the thickening agents used in greases. Should therefore be regarded as capable of causing long term adverse effects in the aquatic environment.

Mobility: Volatilization to air is not expected to be a significant fate process due to the low vapor pressure of this material.

Components may behave differently in the aquatic environment with soaps dispersing and dissolving to some extent in water while the hydrocarbons will float on the surface due to their low water solubility. The hydrocarbon portion would be expected to show low mobility in soil and water. The major environmental fate would be expected to be biodegradation.

Product Name: Nook Industries PAG-1 Grease
(Part number NLU-1001)
Revision Date: 23 Sept 2013
Page 6 of 8



Persistence and degradability: The base oil constituents of greases are expected to be inherently, but not readily biodegradable.

Some of the thickening agents may be readily biodegradable.

Bioaccumulation Potential: Log Kow values measured for the hydrocarbon components of this material range from 4 to over 6, and therefore regarded as having the potential to bioaccumulate. In practice, metabolic processes may reduce bioconcentration.

SECTION 13 DISPOSAL CONSIDERATIONS

The generator of a waste is always responsible for making proper hazardous waste determinations and needs to consider state and local requirements in addition to federal regulations.

This material, if discarded as produced, would not be a federally regulated RCRA "listed" hazardous waste and is not believed to exhibit characteristics of hazardous waste. See Sections 7 and 8 for information on handling, storage and personal protection and Section 9 for physical/chemical properties. It is possible that the material as produced contains constituents which are not required to be listed in the MSDS but could affect the hazardous waste determination. Additionally, use which results in chemical or physical change of this material could subject it to regulation as a hazardous waste.

This material under most intended uses would become "Used Oil" due to contamination by physical or chemical impurities. Whenever possible, Recycle Used Oil in accordance with applicable federal and state or local regulations. Container contents should be completely used and containers should be emptied prior to discard.

SECTION 14 TRANSPORTATION INFORMATION

U.S. DEPARTMENT OF TRANSPORTATION (DOT)

Shipping Description: Not regulated

NOTE: If shipped by land in a packaging having a capacity of 3,500 gallons or more, the provisions of 49 CFR, Part 130 apply. (Contains oil)

INTERNATIONAL MARITIME DANGEROUS GOODS (IMDG)

Shipping Description: Not regulated

NOTE: U.S. DOT compliance requirements may apply. See 49 CFR 171.22, 23 & 25.

INTERNATIONAL CIVIL AVIATION ORG.

INTERNATIONAL AIR TRANSPORT ASSOC. (ICAO/IATA)

UN/ID #: Not regulated

NOTE: U.S. DOT compliance requirements may apply. See 49 CFR 171.22, 23 & 24.

	LTD. QTY	PASSENGER AIRCRAFT	CARGO AIRCRAFT ONLY
Packaging Instruction #:	---	---	---
Max. Net Qty. Per Package:	---	---	---
Packaging Instruction # after 12/31/2010:			

Product Name: Nook Industries PAG-1 Grease
(Part number NLU-1001)
Revision Date: 23 Sept 2013
Page 7 of 8



SECTION 15 REGULATORY INFORMATION

CERCLA/SARA

Section 302 Extremely Hazardous Substances and TPQs (in pounds):

This material does not contain any chemicals subject to the reporting requirements of SARA 302 and 40 CFR 372.

CERCLA/SARA

Section 311/312 (Title III Hazard Categories)

Acute Health: Yes
Chronic Health: No
Fire Hazard: No
Pressure Hazard: No
Reactive Hazard: No

COMPONENT	RQ
Calcium Dodecylbenzenesulfonate	1000 lb

CALIFORNIA PROPOSITION 65

WARNING: This material may contain detectable quantities of the following chemicals, known to the State of California to cause cancer, birth defects or other reproductive harm, and which may be subject to the requirements of California Proposition 65 (CA Health & Safety Code Section 25249.5):

COMPONENT	TYPE OF TOXICITY
1-Naphthylamine	Cancer
2-Naphthylamine	Cancer

CANADIAN REGULATIONS

This product has been classified in accordance with the hazard criteria of the Controlled Products Regulations (CPR) and the MSDS contains all the information required by the Regulations.

WHMIS Hazard Class D2B

NATIONAL CHEMICAL INVENTORIES:

All components are either listed on the US TSCA Inventory, or are not regulated under TSCA.

All components are either on the DSL, or are exempt from DSL listing requirements.

U.S. Export Control Classification Number: EAR99

Product Name: Nook Industries PAG-1 Grease
(Part number NLU-1001)
Revision Date: 23 Sept 2013
Page 8 of 8



SECTION 16 OTHER INFORMATION

Date of Issue:	06-Aug-2010
Status:	FINAL
Previous Issue Date:	27-Aug-2007
MSDS Number:	778589

Guide to Abbreviations:

ACGIH = American Conference of Governmental Industrial Hygienists

CASRN = Chemical Abstracts Service Registry Number

CEILING = Ceiling Limit (15 minutes)

CERCLA = The Comprehensive Environmental Response, Compensation, and Liability Act

EPA = Environmental Protection Agency

IARC = International Agency for Research on Cancer

LEL = Lower Explosive Limit

NE = Not Established

NFPA = National Fire Protection Association

NTP = National Toxicology Program

OSHA = Occupational Safety and Health Administration

PEL = Permissible Exposure Limit (OSHA)

SARA = Superfund Amendments and Reauthorization Act

STEL = Short Term Exposure Limit (15 minutes)

TLV = Threshold Limit Value (ACGIH)

TWA = Time Weighted Average (8 hours)

UEL = Upper Explosive Limit

WHMIS = Worker Hazardous Materials Information System (Canada)



MATERIAL SAFETY DATA SHEET

76 Unax AW 32, 46, 68

1. PRODUCT AND COMPANY IDENTIFICATION

Product Name: 76 Unax AW 32, 46, 68
Product Code: 4641032000, 4642046000, 4643068000
Synonyms: 76 Unax AW 32
 76 Unax AW 46
 76 Unax AW 68
Intended Use: Industrial oil
Chemical Family: Petroleum hydrocarbon
Responsible Party: 76 Lubricants
 A Division of ConocoPhillips
 600 N. Dairy Ashford
 Houston, TX 77079-1175
For Additional MSDSs 800-762-0942
Technical Information: 800-435-7761

The intended use of this product is indicated above. If any additional use is known, please contact us at the Technical Information number listed.

EMERGENCY OVERVIEW

24 Hour Emergency Telephone Numbers:

Spill, Leak, Fire or Accident

California Poison Control System: (800) 356-3129

Call CHEMTREC

North America: (800)424-9300

Others: (703)527-3887 (collect)

Health Hazards/Precautionary Measures: Avoid contact with eyes, skin and clothing. Wash thoroughly after handling.

Physical Hazards/Precautionary Measures: Keep away from all sources of ignition.

Appearance: Clear and bright

Physical form: Liquid

Odor: Mild petroleum

NFPA Hazard Class:

Health: 1 (Slight)

Flammability: 1 (Slight)

Reactivity: 0 (Least)

HMIS Hazard Class

Health: 1 (Slight)

Flammability: 1 (Slight)

Physical Hazard: 0 (Least)

2. COMPOSITION/INFORMATION ON INGREDIENTS

HAZARDOUS COMPONENTS

% WEIGHT

EXPOSURE GUIDELINE

Zinc Compound
CAS# Proprietary

<1

<u>Limits</u>	<u>Agency</u>	<u>Type</u>
Not Established		

<u>OTHER COMPONENTS</u>	<u>% WEIGHT</u>	<u>EXPOSURE GUIDELINE</u>		
		<u>Limits</u>	<u>Agency</u>	<u>Type</u>
Lubricant Base Oil (Petroleum) CAS# Various	>99	(See: Oil Mist, If Generated)		
Additives CAS# Proprietary	<1	Not Established		

<u>REFERENCE</u>	<u>EXPOSURE GUIDELINE</u>		
	<u>Limits</u>	<u>Agency</u>	<u>Type</u>
Oil Mist, If Generated CAS# None	5 mg/m3	ACGIH	TWA
	10 mg/m3	ACGIH	STEL
	5 mg/m3	OSHA	TWA
	2500 mg/m3	NIOSH	IDLH
	5 mg/m3	NOHSC	TWA

The base oil for this product can be a mixture of any of the following highly refined petroleum streams:
CAS 64741-88-4; CAS 64741-89-5; CAS 64741-96-4; CAS 64741-97-5; CAS 64742-01-4; CAS 64742-52-5; CAS 64742-53-6; CAS 64742-54-7; CAS 64742-55-8; CAS 64742-56-9; CAS 64742-57-0; CAS 64742-62-7; CAS 64742-63-8; CAS 64742-65-0; CAS 72623-85-9; CAS 72623-86-0; CAS 72623-87-1

Note: State, local or other agencies or advisory groups may have established more stringent limits. Consult an industrial hygienist or similar professional, or your local agencies, for further information.

1%=10,000 PPM.

All components are listed on the TSCA inventory.

3. HAZARDS IDENTIFICATION

Potential Health Effects:

Eye: Contact may cause mild eye irritation including stinging, watering, and redness.

Skin: Contact may cause mild skin irritation including redness, and a burning sensation. Prolonged or repeated contact can worsen irritation by causing drying and cracking of the skin leading to dermatitis (inflammation). No harmful effects from skin absorption are expected.

Inhalation (Breathing): No information available. Studies by other exposure routes suggest a low degree of toxicity by inhalation.

Ingestion (Swallowing): No harmful effects expected from ingestion.

Signs and Symptoms: Effects of overexposure may include irritation of the nose and throat, irritation of the digestive tract, nausea and diarrhea.

Cancer: Inadequate evidence available to evaluate the cancer hazard of this material. See Section 11 for carcinogenicity information of individual components, if any.

Target Organs: No data available for this material.

Developmental: No data available for this material.

Pre-Existing Medical Conditions: Conditions aggravated by exposure may include skin disorders.

4. FIRST AID MEASURES

Eye: If irritation or redness develops, move victim away from exposure and into fresh air. Flush eyes with clean water. If symptoms persist, seek medical attention.

Skin: Wipe material from skin and remove contaminated shoes and clothing. Cleanse affected area(s) thoroughly by washing with mild soap and water and, if necessary, a waterless skin cleanser. If irritation or redness develops and persists, seek medical attention.

Inhalation (Breathing): If respiratory symptoms develop, move victim away from source of exposure and into fresh air. If symptoms persist, seek medical attention. If victim is not breathing, clear airway and immediately begin artificial respiration. If breathing difficulties develop, oxygen should be administered by qualified personnel. Seek immediate medical attention.

Ingestion (Swallowing): First aid is not normally required; however, if swallowed and symptoms develop, seek medical attention.

Note To Physicians: High-pressure hydrocarbon injection injuries may produce substantial necrosis of underlying tissue despite an innocuous appearing external wound. Often these injuries require extensive emergency surgical debridement and all injuries should be evaluated by a specialist in order to assess the extent of injury.

5. FIRE FIGHTING MEASURES

Flammable Properties: Flash Point: >384°F/>196°C (COC)
OSHA Flammability Class: Not applicable
LEL/UEL%: No Data
Autoignition Temperature: No Data

Unusual Fire & Explosion Hazards: This material may burn, but will not ignite readily. If container is not properly cooled, it can rupture in the heat of a fire.

Extinguishing Media: Dry chemical, carbon dioxide, foam, or water spray is recommended. Water or foam may cause frothing of materials heated above 212°F. Carbon dioxide can displace oxygen. Use caution when applying carbon dioxide in confined spaces.

Fire Fighting Instructions: For fires beyond the incipient stage, emergency responders in the immediate hazard area should wear bunker gear. When the potential chemical hazard is unknown, in enclosed or confined spaces, or when explicitly required by DOT, a self contained breathing apparatus should be worn. In addition, wear other appropriate protective equipment as conditions warrant (see Section 8).

Isolate immediate hazard area, keep unauthorized personnel out. Stop spill/release if it can be done with minimal risk. Move undamaged containers from immediate hazard area if it can be done with minimal risk.

Water spray may be useful in minimizing or dispersing vapors and to protect personnel. Cool equipment exposed to fire with water, if it can be done with minimal risk. Avoid spreading burning liquid with water used for cooling purposes.

6. ACCIDENTAL RELEASE MEASURES

This material may burn, but will not ignite readily. Keep all sources of ignition away from spill/release. Stay upwind and away from spill/release. Notify persons down wind of the spill/release, isolate immediate hazard area and keep unauthorized personnel out. Stop spill/release if it can be done with minimal risk. Wear appropriate protective equipment including respiratory protection as conditions warrant (see Section 8).

Prevent spilled material from entering sewers, storm drains, other unauthorized drainage systems, and natural waterways. Dike far ahead of spill for later recovery or disposal. Spilled material may be absorbed into an appropriate absorbent material.

Notify fire authorities and appropriate federal, state, and local agencies. Immediate cleanup of any spill is recommended. If spill of any amount is made into or upon navigable waters, the contiguous zone, or adjoining shorelines, notify the National Response Center (phone number 800-424-8802).

7. HANDLING AND STORAGE

Handling: Do not enter confined spaces such as tanks or pits without following proper entry procedures such as ASTM D-4276 and 29CFR 1910.146. The use of appropriate respiratory protection is advised when concentrations exceed any established exposure limits (see Sections 2 and 8).

Do not wear contaminated clothing or shoes. Use good personal hygiene practices.

High pressure injection of hydrocarbon fuels, hydraulic oils or greases under the skin may have serious consequences even though no symptoms or injury may be apparent. This can happen accidentally when using high pressure equipment such as high pressure grease guns, fuel injection apparatus or from pinhole leaks in tubing of high pressure hydraulic oil equipment.

"Empty" containers retain residue and may be dangerous. Do not pressurize, cut, weld, braze, solder, drill, grind, or expose such containers to heat, flame, sparks, or other sources of ignition. They may explode and cause injury or death. "Empty" drums should be completely drained, properly bunged, and promptly shipped to the supplier or a drum reconditioner. All containers should be disposed of in an environmentally safe manner and in accordance with governmental regulations.

Before working on or in tanks which contain or have contained this material, refer to OSHA regulations, ANSI Z49.1 and other references pertaining to cleaning, repairing, welding, or other contemplated operations.

Storage: Keep container(s) tightly closed. Use and store this material in cool, dry, well-ventilated areas away from heat and all sources of ignition. Store only in approved containers. Keep away from any incompatible material (see Section 10). Protect container(s) against physical damage.

8. EXPOSURE CONTROLS/PERSONAL PROTECTION

Engineering controls: If current ventilation practices are not adequate to maintain airborne concentrations below the established exposure limits (see Section 2), additional engineering controls may be required.

Personal Protective Equipment (PPE):

Respiratory: A NIOSH certified air purifying respirator with a Type 95 (R or P) particulate filter may be used under conditions where airborne concentrations are expected to exceed exposure limits (see Section 2).

Protection provided by air purifying respirators is limited (see manufacturer's respirator selection guide). Use a NIOSH approved self-contained breathing apparatus (SCBA) or equivalent operated in a pressure demand or other positive pressure mode if there is potential for an uncontrolled release, exposure levels are not known, or any other circumstances where air purifying respirators may not provide adequate protection. A respiratory protection program that meets OSHA's 29 CFR 1910.134 and ANSI Z88.2 requirements must be followed whenever workplace conditions warrant a respirator's use.

Skin: The use of gloves impervious to the specific material handled is advised to prevent skin contact and possible irritation (see manufacturers literature for information on permeability).

Eye/Face: Approved eye protection to safeguard against potential eye contact, irritation, or injury is recommended. Depending on conditions of use, a face shield may be necessary.

Other Protective Equipment: A source of clean water should be available in the work area for flushing eyes and skin. Impervious clothing should be worn as needed.

Suggestions for the use of specific protective materials are based on readily available published data. Users should check with specific manufacturers to confirm the performance of their products.

9. PHYSICAL AND CHEMICAL PROPERTIES

Note: Unless otherwise stated, values are determined at 20°C (68°F) and 760 mm Hg (1 atm).

Appearance: Clear and bright

Physical State: Liquid

Odor: Mild petroleum

pH: Not applicable

Vapor Pressure (mm Hg): <1

Vapor Density (air=1): >1

Boiling Point/Range: No Data

Freezing/Melting Point: <-27°F / <-33°C

Solubility in Water: Negligible

Specific Gravity: 0.855-0.871

Percent Volatile: Negligible

Evaporation Rate (nBuAc=1): Negligible

Viscosity: 22-68 cSt @ 40°C / 4.3-8.7 cSt @ 100°C

Bulk Density: 7.13-7.26 lb/gal

Flash Point: >384°F / >196°C (COC)

Flammable/Explosive Limits (%): No Data

10. STABILITY AND REACTIVITY

Stability: Stable under normal ambient and anticipated storage and handling conditions of temperature and pressure.

Conditions To Avoid: Extended exposure to high temperatures can cause decomposition.

Materials to Avoid (Incompatible Materials): Avoid contact with strong oxidizing agents.

Hazardous Decomposition Products: Combustion can yield carbon, nitrogen, sulfur, phosphorus, and zinc oxides.

Hazardous Polymerization: Will not occur.

11. TOXICOLOGICAL INFORMATION

Lubricant Base Oil (Petroleum) (CAS# Various)

Carcinogenicity: The petroleum base oils contained in this product have been highly refined by a variety of processes including solvent extraction, hydrotreating, and dewaxing to remove aromatics and improve performance characteristics. None of the oils used are listed as a carcinogen by NTP, IARC, or OSHA.

12. ECOLOGICAL INFORMATION

Not evaluated at this time

13. DISPOSAL CONSIDERATIONS

This material under most intended uses would become used oil due to contamination by physical or chemical impurities. RECYCLE ALL USED OIL. While being recycled, used oil is regulated by 40 CFR 279. Use resulting in chemical or physical change or contamination may also subject it to regulation as hazardous waste. Under federal regulations, used oil is a solid waste managed under 40 CFR 279. However, in California, used oil is managed as hazardous waste until tested to show it is not hazardous. Consult state and local regulations regarding the proper handling of used oil. In the case of used oil, the intent to discard it may cause the used oil to be regulated as hazardous waste.

Contents should be completely used and containers emptied prior to discard. Rinsate may be considered a RCRA hazardous waste and must be disposed of with care and in compliance with federal, state and local regulations. Large empty containers, such as drums, should be returned to the distributor or a drum reconditioner. To assure proper disposal of small empty containers, consult with state and local regulations and disposal authorities.

14. TRANSPORT INFORMATION

DOT Shipping Description: Not classified as hazardous

15. REGULATORY INFORMATION

EPA SARA 311/312 (Title III Hazard Categories):

Acute Health: No
Chronic Health: No
Fire Hazard: No
Pressure Hazard: No
Reactive Hazard: No

SARA 313 and 40 CFR 372:

This material contains the following chemicals subject to the reporting requirements of SARA 313 and 40 CFR 372:

Component	CAS Number	Weight %
Zinc Compound	Proprietary	<1

California Proposition 65:

Warning: This material contains the following chemicals which are known to the State of California to cause cancer, birth defects or other reproductive harm, and are subject to the requirements of California Proposition 65 (CA Health & Safety Code Section 25249.5):

--None Known--

Carcinogen Identification:

This material has not been identified as a carcinogen by NTP, IARC, or OSHA. See Section 11 for carcinogenicity information of individual components, if any.

EPA (CERCLA) Reportable Quantity:

--None--

Canada - Domestic Substances List: Listed

WHMIS Class:

Not regulated

This product has been classified in accordance with the hazard criteria of the Controlled Products Regulations (CPR) and the MSDS contains all the information required by the CPR.

16. OTHER INFORMATION

Issue Date: 02/06/03

(MSDS: 722330)

Page 7 of 7

Previous Issue Date: 01/01/02
Product Code: 4641032000, 4642046000, 4643068000
Revised Sections: New Format
Previous Product Code: 4641032000
MSDS Number: 722330
Status: Final

Disclaimer of Expressed and Implied Warranties:

The information presented in this Material Safety Data Sheet is based on data believed to be accurate as of the date this Material Safety Data Sheet was prepared. **HOWEVER, NO WARRANTY OF MERCHANTABILITY, FITNESS FOR ANY PARTICULAR PURPOSE, OR ANY OTHER WARRANTY IS EXPRESSED OR IS TO BE IMPLIED REGARDING THE ACCURACY OR COMPLETENESS OF THE INFORMATION PROVIDED ABOVE, THE RESULTS TO BE OBTAINED FROM THE USE OF THIS INFORMATION OR THE PRODUCT, THE SAFETY OF THIS PRODUCT, OR THE HAZARDS RELATED TO ITS USE.** No responsibility is assumed for any damage or injury resulting from abnormal use or from any failure to adhere to recommended practices. The information provided above, and the product, are furnished on the condition that the person receiving them shall make their own determination as to the suitability of the product for their particular purpose and on the condition that they assume the risk of their use. In addition, no authorization is given nor implied to practice any patented invention without a license.

 **CLIMAX**

 **BORTECH**  **CALDER** **H&S** **TOOL**