

CE

SPEED FACER

REFRENTADORA RÁPIDA ODF40

MANUAL DE SERVICIO

TRADUCCIÓN DE LAS INSTRUCCIONES ORIGINALES



H&S TOOL

A CLIMAX COMPANY

P/N 87499
Marzo 2017
Revisión 1

CLIMAX
Family of Brands

BORTECH

CALDER
TESTERS

H&S TOOL

©2017 Climax Portable Machining and Welding Systems o sus filiales.
Todos los derechos reservados.

Salvo indicación expresa en contrario, está prohibido reproducir, copiar, transmitir, difundir o almacenar en cualquier sistema de recuperación el presente manual o partes de él sin el previo consentimiento expreso de Climax. Climax autoriza la descarga de una sola copia de este manual en una unidad de disco duro o en otro medio de almacenamiento electrónico para su visualización, y la impresión de una copia de este manual o de cualquiera de sus revisiones, siempre y cuando dicha copia electrónica o impresa contenga el texto completo de este aviso de copyright y se indique que cualquier distribución comercial no autorizada de este manual o cualquiera de sus revisiones está estrictamente prohibida.

En Climax Portable Machining and Welding Systems valoramos su opinión.

Para preguntas o sugerencias sobre este manual o la documentación Climax, escribanos un mensaje de correo electrónico a documentation@cpmt.com.

Para preguntas o sugerencias sobre los productos o servicios Climax, llame a Climax o escriba un mensaje de correo electrónico a info@cpmt.com. Para un servicio rápido y preciso, indíquenos quién es su representante de fábrica con los siguientes datos:

- Nombre
- Dirección de envío
- Teléfono
- Modelo de máquina
- Número de serie (si procede)
- Fecha de compra

Oficina central mundial de Climax

Climax Portable Machining and Welding Systems
2712 South Second Street Newberg, Oregon 97132 EE.UU.
Teléfono (fuera de EE.UU.) (503) 538-2815
Gratuito (Norteamérica): 1-800-333-8311
Fax: 503.538.7600
email: info@cpmt.com

Oficina central del Reino Unido de Climax

Climax Portable Machine Tools Ltd
Unit 10 Heather Close
Lyme Green Business Park
Macclesfield, Cheshire SK11 0LR, RU
Teléfono: +44 (0) 161 406 1720
email: info@cpmt.com

Oficina central europea de Climax

Climax GmbH
Am Langen Graben 8
52353 Düren, Alemania
Teléfono: +49 (0) 2421-9177-12
email: info@cpmt.de

SEDES DE CLIMAX GLOBAL

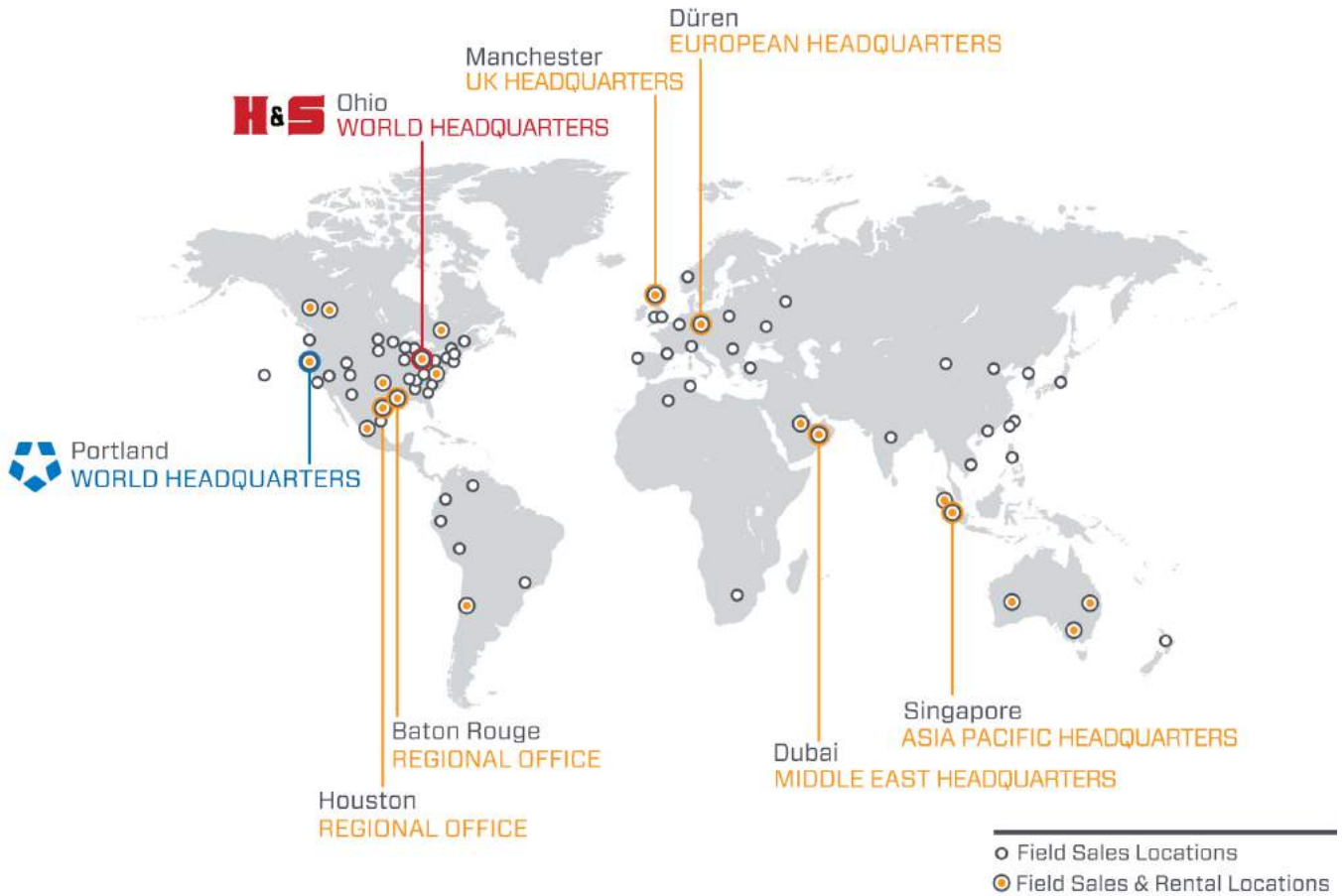

DOCUMENTACIÓN CE

**Name of manufacturer or supplier**

H&S Tool

Full postal address including country of origin

715 Weber Drive
Wadsworth, OH 44281
USA

Description of product

ODF40 Speedfacer Flange Facer

Name, type or model, batch or serial number

Model ODF40

Serial Number Range OD40071601 to
OD40122001

Pneumatic Powered

Standards used, including number, title, issue date and other relative documents

EN 953, EN 3744, EN 4413, EN 4414, EN 11201, EN 12100, EN 13128, EN 13732, EN 13849, EN 13857

Name of Responsible Person within the EU Tom Cunningham**Full postal address if different from manufacturers**

Climax GmbH
Am Langen Graben 8
52353 Duren, Germany

Declaration

I declare that as the Manufacturer, the above information in relation to the supply / manufacture of this product, is in conformity with the stated standards and other related documents following the provisions of the above Directives and their amendments.

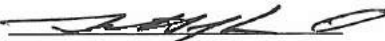
Signature of Manufacturer: Position Held: DIRECTOR OF ENGINEERING; R&DDate: 7/20/2010

GARANTÍA LIMITADA

Climax Portable Machine Tools, Inc. (en adelante «Climax») garantiza que todas las máquinas nuevas están libres de defectos de material y fabricación. Esta garantía es válida para el comprador original por un período de un año a contar desde la entrega. Si el comprador detectara algún defecto de material o fabricación dentro del período de garantía, el comprador original podrá ponerse en contacto con el representante y devolver la máquina completa a la fábrica corriendo con los gastos de envío. Climax decidirá si repara o reemplaza la máquina defectuosa sin costo alguno y la devolverá haciéndose cargo de los costes de envío.

Climax garantiza que todas las piezas están libres de defectos de material y fabricación y que todo el trabajo ha sido ejecutado de forma correcta. Esta garantía es válida para las piezas adquiridas o la mano de obra contratada por el cliente por un período de 90 días a contar a partir de la entrega de la pieza o la máquina reparada o 180 días sobre máquinas y componentes usados. Si el cliente que ha adquirido piezas o contratado mano de obra detectara algún defecto de material o fabricación dentro del período de garantía, el comprador podrá ponerse en contacto con el representante de fábrica y devolver la pieza o la máquina reparada corriendo con los gastos de envío. Climax decidirá si repara o reemplaza la pieza defectuosa o corrige cualquier defecto de fabricación sin costo alguno en ambos casos y devolverá la pieza o la máquina reparada haciéndose cargo de los costes de envío.

Estas garantías no cubren lo siguiente:

- Daños posteriores a la fecha de envío que no han sido causados por defectos de material o fabricación
- Daños causados por un mantenimiento impropio o inadecuado de la máquina
- Daños causados por modificaciones o reparaciones no autorizadas en la máquina
- Daños causados por el abuso de la máquina
- Daños causados por usar la máquina por encima de su capacidad

Todas las demás garantías expresas o implícitas, incluyendo sin restricciones las garantías de comercialización y adecuación para una finalidad concreta, quedan excluidas y descartadas.

Términos de venta

Asegúrese de revisar los términos de venta que aparecen en el dorso de la factura. Estos términos controlan y limitan sus derechos en lo que respecta a los bienes adquiridos en Climax.

Acerca de este manual

Climax proporciona de buena fe los contenidos del presente manual como guía para el operador. Climax no puede garantizar que la información contenida en este manual sea correcta para aplicaciones distintas a la descrita en este manual. Especificaciones de producto sujetas a cambios sin previo aviso.

TABLA DE CONTENIDOS

CAPÍTULO/APARTADO	PÁGINA
1 INTRODUCCIÓN	1
1.1 CÓMO UTILIZAR ESTE MANUAL	1
1.2 ALERTAS DE SEGURIDAD	1
1.3 INDICACIONES DE SEGURIDAD GENERALES	2
1.4 INDICACIONES DE SEGURIDAD ESPECÍFICAS DE LA MÁQUINA	2
1.5 ANÁLISIS DE RIESGOS Y MITIGACIÓN DE LAS AMENAZAS	4
1.6 LISTA DE VERIFICACIÓN DEL ANÁLISIS DE RIESGOS	5
1.7 ETIQUETAS	6
1.7.1 Identificación de las etiquetas	6
1.7.2 Ubicación de las etiquetas	7
2 SINOPSIS	9
2.1 CARACTERÍSTICAS Y COMPONENTES	9
2.2 CONTROLES	10
2.3 DIMENSIONES	10
2.4 ESPECIFICACIONES	12
2.5 ELEMENTOS NECESARIOS PERO NO SUMINISTRADOS	12
3 CONFIGURACIÓN	13
3.1 RECEPCIÓN E INSPECCIÓN	13
3.2 SISTEMA DE ELEVACIÓN Y APAREJOS	13
3.3 PELIGROS DURANTE LA INSTALACIÓN	15
3.3.1 Montaje horizontal	16
3.3.2 Montaje vertical	16
3.3.3 Montaje por encima de la cabeza	17
3.4 ENSAMBLAJE DE LA MÁQUINA	17
3.4.1 Centrado y nivelación	18
3.4.2 Instalación de la cuchilla o el cincel	19
3.4.3 Rotación del cabezal de la herramienta	20
3.4.4 Ajuste del avance	20
3.4.5 Instalación del motor de accionamiento	21
3.4.6 Conexión del distribuidor neumático	21
4 SERVICIO	23
4.1 COMPROBACIONES PREVIAS AL SERVICIO	23
4.2 MODOS DE SERVICIO	23
4.2.1 Configuración para refrentar bridas	23
4.2.2 Configuración para avellanar	24
4.2.3 Instalación del accesorio de refrentado posterior	24

TABLA DE CONTENIDOS (CONTINUACIÓN)

CAPÍTULO/APARTADO	PÁGINA
4.3 SERVICIO	25
4.3.1 Arranque de la máquina	25
4.3.2 Detención de la máquina	26
4.3.3 Configuración de la máquina	26
5 MANTENIMIENTO	27
5.1 LISTA DE VERIFICACIÓN PARA EL MANTENIMIENTO	27
5.2 LUBRICANTES AUTORIZADOS	27
5.3 TAREAS DE MANTENIMIENTO	28
5.3.1 Verificación de la reserva de aceite del distribuidor neumático y del filtro colector de partículas	28
5.3.2 Verificación del circuito de goteo del distribuidor neumático	29
5.3.3 Comprobación de la parada de emergencia	29
5.3.4 Guías de cola de milano	29
5.3.5 Instalación y eliminación de protecciones	29
5.3.6 Ajuste del rodillo	30
5.4 RESOLUCIÓN DE AVERÍAS	31
5.4.1 La máquina no gira	31
5.4.2 La máquina no avanza	31
5.4.3 La máquina no funciona bien	31
5.4.4 La máquina no corta plano	31
6 ALMACENAMIENTO Y ENVÍO	33
6.1 ALMACENAMIENTO	33
6.1.1 Almacenamiento breve	33
6.1.2 Almacenamiento prolongado	33
6.2 ENVÍO	34
6.3 DESGUACE	34
APÉNDICE A DIBUJOS DE MONTAJE	35
APÉNDICE B SDS	53

LISTA DE FIGURAS

FIGURA	PÁGINA
1-1 Ubicación de la etiqueta ODF40	8
1-2 Ubicación de la etiqueta 60220 (debajo de la máquina)	8
2-1 Soporte ampliado instalado	9
2-2 Controles del distribuidor neumático	10
2-3 Dimensiones de la Refrentadora Rápida ODF40 (P/N 86870)	11
3-1 Puntos de elevación (mostrados en la máquina ODF40)	14
3-2 Peligro vertical	15
3-3 Preparativos para el montaje	16
3-4 Orificio de montaje alternado	17
3-5 Pernos y orificios	18
3-6 Componentes de la pata regulable	18
3-7 Indicador de dial montado para nivelación	19
3-8 Ubicación de la tuerca de sujeción oscilante	19
3-9 Ubicación del activador de avance	20
3-10 Ajustes de avance	21
3-11 Motor neumático instalado	21
4-1 Tornillos de bloqueo de cuña	24
4-2 Componentes para el refrentado posterior	24
4-3 Controles del distribuidor neumático	25
4-4 Tornillo de regulación de avance y botón de dirección de avance	25
5-1 Llave de estrella encima del tornillo	30
5-2 Punzones utilizados para la instalación de protecciones	30
5-3 Llave de ajuste del rodillo (P/N 86988)	30
6-1 Caja ODF40	34
A-1 Montaje de la Refrentadora Rápida ODF40 (P/N 86870)	36
A-2 Montaje de las etiquetas de la Refrentadora Rápida ODF40 (P/N 86870)	37
A-3 Lista de piezas de la Refrentadora Rápida ODF40 (P/N 86870)	38
A-4 Montaje del portaherramientas de la corredera (P/N 79790)	39
A-5 Lista de piezas del portaherramientas de la corredera (P/N 79790)	40
A-6 Montaje de la unidad de acondicionamiento neumático (P/N 83430)	41
A-7 Montaje de la unidad de acondicionamiento neumático (P/N 83430)	42
A-8 Montaje de nivelación de las patas de elevación (P/N 86880)	43
A-9 Montaje del eje radial (P/N 86890)	44
A-10 Lista de piezas de montaje del eje radial (P/N 86890)	45
A-11 Montaje de la caja de alimentación del cable de tracción (P/N 86900)	46
A-12 Actuador de avance en el montaje de la caja de alimentación del cable de tracción (P/N 86900)	47
A-13 Montaje del activador de avance (P/N 86910)	48
A-14 Montaje del motor de accionamiento (P/N 86989)	49
A-15 Montaje de la pata de prolongación (P/N 87164)	50
A-16 Montaje del accesorio de refrentado posterior (P/N 87310)	51

Esta página ha sido intencionalmente dejada en blanco

LISTA DE TABLAS

TABLA	PÁGINA
1-1 Niveles acústicos	3
1-2 Lista de verificación del análisis de riesgos previa al ajuste	5
1-3 Lista de verificación del análisis de riesgos posterior al ajuste	5
1-4 Refrentadora Rápida ODF40 etiquetas	6
2-1 Masa de los subcomponentes	12
3-1 Patas de montaje OD40	18
5-1 Intervalos y tareas de mantenimiento	27
5-2 Lubricantes autorizados	28
A-1 Kit de herramientas P/N 78530	52

Esta página ha sido intencionalmente dejada en blanco

1 INTRODUCCIÓN

EN ESTE CAPÍTULO:

1.1 CÓMO UTILIZAR ESTE MANUAL	1
1.2 ALERTAS DE SEGURIDAD	1
1.3 INDICACIONES DE SEGURIDAD GENERALES	2
1.4 INDICACIONES DE SEGURIDAD ESPECÍFICAS DE LA MÁQUINA	2
1.5 ANÁLISIS DE RIESGOS Y MITIGACIÓN DE LAS AMENAZAS	4
1.6 LISTA DE VERIFICACIÓN DEL ANÁLISIS DE RIESGOS	5
1.7 ETIQUETAS	6
1.7.1 IDENTIFICACIÓN DE LAS ETIQUETAS	6
1.7.2 UBICACIÓN DE LAS ETIQUETAS	7

1.1 CÓMO UTILIZAR ESTE MANUAL

El presente manual proporciona la información necesaria para configurar, manejar, mantener, almacenar, enviar y eliminar la Refrentadora Rápida ODF40.

La primera página de cada capítulo incluye un resumen para facilitar la búsqueda de información. Los apéndices contienen información adicional sobre el producto para facilitar la configuración, el manejo y las tareas de mantenimiento.

Lea el manual completo para familiarizarse con la Refrentadora Rápida ODF40 antes de configurarla o manejarla.

1.2 ALERTAS DE SEGURIDAD

Tenga en cuenta las alertas de seguridad impresas a lo largo del manual. Las alertas de seguridad advierten de situaciones peligrosas específicas que pueden producirse mientras se maneja la máquina.

Ejemplo de alertas de seguridad empleadas en este manual¹:

PELIGRO

Indica una situación peligrosa que, si no se evita, **TIENE** como consecuencia la muerte o lesiones graves.

1. Para más información acerca de las alertas de seguridad, consulte la norma *ANSI/NEMA Z535.6-2011, Información sobre la seguridad del producto en manuales, instrucciones y otros materiales afines.*

ADVERTENCIA

Indica una situación peligrosa que, si no se evita, **PODRÍA TENER** como consecuencia la muerte o lesiones graves.

PRECAUCIÓN

Indica una situación peligrosa que, si no se evita, podría tener como consecuencia lesiones leves o moderadas.

NOTA

Indica una situación peligrosa que, si no se evita, podría tener como consecuencia daños materiales, el fallo del equipo o unos resultados de trabajo no deseados.

1.3 INDICACIONES DE SEGURIDAD GENERALES

H&S es pionera en promocionar un uso seguro de las máquinas herramienta portátiles. La seguridad es un trabajo conjunto. Como usuario final, también debe poner de su parte siendo consciente de su entorno de trabajo y siguiendo al pie de la letra los procedimientos de servicio y las indicaciones de seguridad incluidas en este manual, así como las normas de seguridad de su empresa.

Tenga en cuenta las siguientes indicaciones de seguridad cuando maneje o trabaje cerca de la máquina.

Formación: antes de manejar esta o cualquier otra máquina herramienta, deberá recibir formación por parte de un instructor cualificado. Póngase en contacto con H&S para obtener información sobre cursos específicos de máquinas.

Análisis de riesgos: trabajar con o cerca de la máquina supone un riesgo para su seguridad. Como usuario final, es responsable de llevar a cabo un análisis de riesgos de cada lugar de trabajo antes de poner en servicio y manejar esta máquina.

Uso previsto: utilice esta máquina en conformidad con las instrucciones e indicaciones de este manual. No utilice esta máquina para una finalidad distinta a la prevista en el presente manual.

Equipamiento de protección personal: utilice siempre un equipo de protección personal adecuado cuando maneje esta u otra máquina herramienta. Se recomienda utilizar ropa resistente a las llamas de manga larga para brazos y piernas cuando se utilice la máquina. Las virutas calientes de la pieza de trabajo pueden producir quemaduras o cortes en la piel.

Área de trabajo: mantenga ordenada el área de trabajo alrededor de la máquina. Sujete los

cables y los tubos flexibles conectados a la máquina. Mantenga los demás cables y tubos flexibles alejados del área de trabajo.

Sistema de elevación: muchos de los componentes de la máquina H&S son muy pesados. Siempre que sea posible, eleve la máquina o sus componentes utilizando un equipo o aparejo de elevación adecuado. Utilice siempre los puntos de elevación de la máquina previstos para ello. Siga las instrucciones de los procedimientos de configuración del presente manual.

Bloqueo/señalización: bloquee y señalice la máquina antes de llevar a cabo el mantenimiento.

Piezas móviles: las máquinas H&S tienen un gran número de piezas móviles e interconexiones expuestas que pueden ocasionar fuertes golpes, pinchazos, cortes y otras lesiones. Salvo que sea para llevar a cabo comprobaciones de servicio estacionarias, evite tocar las piezas móviles con las manos o herramientas mientras la máquina está en funcionamiento. Recójase el cabello, quítese los guantes y las joyas y saque todos los objetos de sus bolsillos para evitar que se enreden en las piezas móviles.

Bordes afilados: las herramientas de corte y las piezas de trabajo tienen bordes afilados que pueden provocar cortes en la piel con mucha facilidad. Use guantes de protección y proceda con precaución cuando manipule una herramienta de corte o pieza de trabajo.

Superficies calientes: los motores, las bombas, las unidades hidráulicas y las herramientas de corte pueden generar suficiente calor como para causar quemaduras graves. Tenga en cuenta las etiquetas de aviso de superficie caliente y no las toque con las manos desprotegidas hasta que la máquina se haya enfriado.

1.4 INDICACIONES DE SEGURIDAD ESPECÍFICAS DE LA MÁQUINA

Riesgo ocular: esta máquina lanza virutas metálicas durante su funcionamiento. Utilice siempre gafas protectoras cuando maneje la máquina.

Entornos peligrosos: no utilice la máquina en entornos donde existan materiales potencialmente explosivos, sustancias tóxicas o haya

radiación.

Nivel acústico: esta máquina produce niveles acústicos potencialmente dañinos. Es obligatorio utilizar protección auditiva cuando maneje esta máquina o trabaje cerca de ella. Durante las pruebas, la máquina produjo los niveles

acústicos¹ relacionados a continuación en la Tabla 1-1.

TABLA 1-1. NIVELES ACÚSTICOS

	Motor
Potencia acústica	102,3 dBA
Presión acústica para el operador	87,6 dBA
Presión acústica para el observador	85 dBA

1. El ensayo acústico de la máquina se realizó en conformidad con las normas armonizadas europeas EN ISO 3744:2010 y EN 11201:2010.

Montaje de la máquina: no utilice la máquina salvo que esté montada en una pieza de trabajo en conformidad con el presente manual. Si la máquina se monta a una altura por encima de la cabeza o en posición vertical, no retire los aparos de elevación hasta que la máquina esté montada en la pieza de trabajo en conformidad con el presente manual.

Sea cual sea la posición de montaje, compruebe que la máquina esté fijada y montada de tal forma que si patina o rueda, no cause lesiones ni daños.

1.5 ANÁLISIS DE RIESGOS Y MITIGACIÓN DE LAS AMENAZAS

Las máquinas herramienta han sido diseñadas específicamente para ejecutar con precisión tareas de eliminación de material.

Las máquinas herramienta estacionarias suelen ser tornos y fresadoras y se encuentran normalmente en un taller de maquinaria. Se instalan en espacios permanentes durante su funcionamiento y se consideran máquinas completas e independientes. Las máquinas herramienta estacionarias ofrecen la rigidez necesaria para llevar a cabo tareas de eliminación de material desde la estructura, que forma una parte integral de la máquina herramienta.

Las máquinas herramienta portátiles han sido diseñadas para aplicaciones de mecanizado en sitio. Normalmente se acoplan directamente a la pieza de trabajo o a una estructura adyacente y alcanzan su rigidez desde la estructura a la cual está acoplada. El objetivo del diseño es que la máquina herramienta portátil y la estructura a la cual está acoplada se conviertan en una máquina completa durante el proceso de eliminación de material.

Para obtener los resultados deseados y para favorecer la seguridad, el operador debe entender y respetar la finalidad de uso, así como el ajuste y el funcionamiento específico de las máquinas herramienta portátiles.

El operador debe ejecutar una comprobación general y un análisis de riesgos en sitio de la aplicación prevista. Debido a la naturaleza única de las aplicaciones de mecanizado portátiles es habitual identificar uno o varios peligros y afrontarlos.

Al realizar un análisis de riesgos en sitio, es importante considerar la máquina herramienta portátil y la pieza de trabajo como un solo conjunto.

1.6 LISTA DE VERIFICACIÓN DEL ANÁLISIS DE RIESGOS

La siguiente lista de verificación no es una lista exhaustiva de las cosas que deben comprobarse cuando se ajusta y maneja esta máquina herramienta portátil.

Sin embargo, estas listas de verificación incluyen los tipos de riesgo habituales que el instalador y el operador deben tener en cuenta. Utilice estas listas de verificación como parte del análisis de riesgos:

TABLA 1-2. LISTA DE VERIFICACIÓN DEL ANÁLISIS DE RIESGOS PREVIA AL AJUSTE

Antes del ajuste	
<input type="checkbox"/>	Tengo en cuenta todas las etiquetas de advertencia de la máquina.
<input type="checkbox"/>	He eliminado o mitigado todos los riesgos identificados (como tropiezos, cortes, aplastamientos, enredos, cizallamiento o la caída de objetos).
<input type="checkbox"/>	He considerado la necesidad de sistemas de seguridad personales y he instalado los necesarios.
<input type="checkbox"/>	He leído las instrucciones de montaje de la máquina (Apartado 3.3) y he inventariado todos los elementos necesarios pero no suministrados (Apartado 2.5).
<input type="checkbox"/>	He creado un plan de elevación que describe el aparejo más adecuado para cada trabajo de elevación necesario durante la configuración de la estructura de soporte y la máquina.
<input type="checkbox"/>	He determinado las trayectorias de caída posibles en las operaciones de elevación y manipulación. He adoptado medidas preventivas para mantener alejados a los trabajadores de la trayectoria de caída calculada.
<input type="checkbox"/>	He considerado cómo funciona esta máquina y he identificado la mejor ubicación para los controles, los cables y el operador.
<input type="checkbox"/>	He evaluado y mitigado cualquier otro riesgo potencial específico de mi área de trabajo.

TABLA 1-3. LISTA DE VERIFICACIÓN DEL ANÁLISIS DE RIESGOS POSTERIOR AL AJUSTE

Después del ajuste	
<input type="checkbox"/>	He comprobado que la máquina ha sido instalada de forma segura (conforme al Apartado 3) y que la trayectoria de caída es clara. Si la máquina se ha instalado en un lugar elevado, he comprobado que la máquina está asegurada para evitar que se caiga.
<input type="checkbox"/>	He identificado todos los posibles puntos de aplastamiento como los causados por las piezas rotativas y he informado al personal afectado.
<input type="checkbox"/>	He previsto detener cualquier viruta o esquirla producida por la máquina.
<input type="checkbox"/>	He seguido los intervalos de mantenimiento estipulados (Apartado 5.1) con los lubricantes recomendados (Apartado 5.2).
<input type="checkbox"/>	He comprobado que todo el personal afectado dispone del equipo de protección personal recomendado, así como el equipamiento estipulado o requerido en la obra en cuestión.
<input type="checkbox"/>	He comprobado que el personal afectado ha entendido y tiene clara la zona de peligro.
<input type="checkbox"/>	He evaluado y mitigado cualquier otro riesgo potencial específico de mi área de trabajo.

1.7 ETIQUETAS

1.7.1 Identificación de las etiquetas

Las siguientes etiquetas de advertencia deben estar colocadas en la máquina. Si falta alguna o está borrosa, póngase en contacto inmediatamente con H&S para solicitar un repuesto.

TABLA 1-4. REFRENTADORA RÁPIDA ODF40 ETIQUETAS











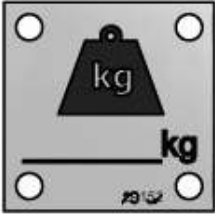



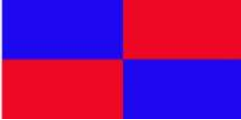

	<p>P/N 29152 Placa de masa</p>		<p>P/N 46902 Etiqueta de advertencia: superficie caliente</p>
	<p>P/N 59039 Etiqueta de advertencia: punto de elevación</p>		<p>P/N 59042 Etiqueta de advertencia: peligro de atraparse las manos en las piezas móviles</p>
<p>HOSE ARR </p> <p>BASE </p>	<p>PN 60219 Esquema de conexión de tubos flexibles para rojo-rojo/azul-azul</p>	<p>HOSE ARR </p> <p>BASE </p>	<p>PN 60220 Esquema de conexión de tubos flexibles para azul rojo/rojo azul</p>
	<p>PN 79324 Etiqueta de advertencia: peligro de atraparse las manos en los engranajes rotativos</p>		<p>PN 79385 Etiqueta de advertencia: elevar solo el subconjunto; comprobar el manual de servicio</p>

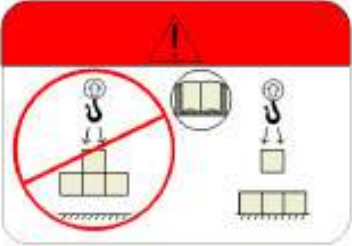
TABLA 1-4. REFRENTADORA RÁPIDA ODF40 ETIQUETAS

	<p>PN 84856 Etiqueta de advertencia: fijar la máquina antes de usarla</p>		
	<p>PN 87259 Etiqueta H&S Refrentadora Rápida ODF40</p>		
	<p>PN 87265 Flecha negra sobre fondo amarillo</p>		<p>PN 87269 Placa en serie H&S</p>
	<p>PN 87271 Etiqueta de advertencia: utilice gafas de protección y protección auditiva y lea el manual de servicio</p>		<p>PN 87272 Etiqueta «Made in the USA»</p>
	<p>PN 87427 Etiqueta H&S ODF40</p>		

1.7.2 Ubicación de las etiquetas

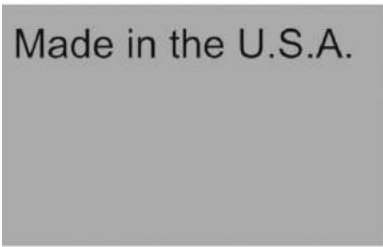
Las siguientes figuras muestran la ubicación de las etiquetas en cada uno de los componentes de la Refrentadora Rápida ODF40.

Para más detalles sobre la ubicación, consulte la vista en despiece del Apéndice A.



FIGURA 1-1. UBICACIÓN DE LA ETIQUETA ODF40

Etiqueta P/N: 29152, 46902, 59039, 59042, 60219, 79324, 79385, 84856, 87259, 87265, 87269, 87271, 87272, 87427



FIGURA 1-2. UBICACIÓN DE LA ETIQUETA 60220 (DEBAJO DE LA MÁQUINA)

Etiqueta P/N: 60220

2 SINOPSIS

EN ESTE CAPÍTULO:

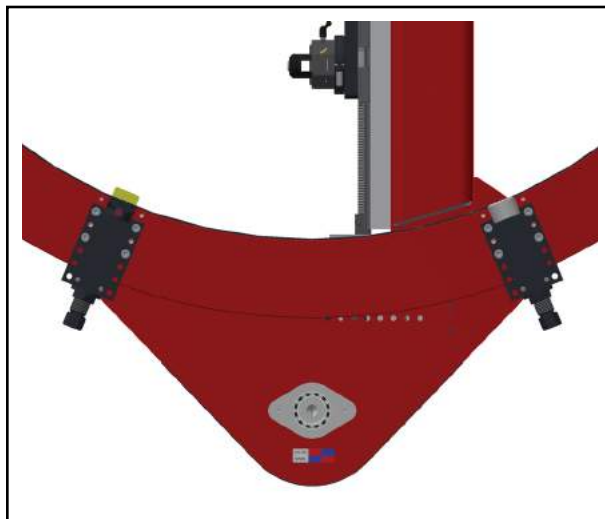
2.1 CARACTERÍSTICAS Y COMPONENTES	9
2.2 CONTROLES	10
2.3 DIMENSIONES	10
2.4 ESPECIFICACIONES	12
2.5 ELEMENTOS NECESARIOS PERO NO SUMINISTRADOS	12

2.1 CARACTERÍSTICAS Y COMPONENTES

La Refrentadora Rápida ODF40 es una refrentadora de bridas neumática y portátil accionada por correa con punto único montado en diámetro exterior destinada para utilizarse en piezas de trabajo con un diámetro exterior de 29,1-40,5" (739-1,029 mm) o 19,1-30,0" (485-762 mm) con el soporte de montaje extendido opcional (mostrado en Figura 2-1).



FIGURA 2-1. SOPORTE AMPLIADO INSTALADO

Los componentes principales incluyen lo siguiente:

Motor neumático: el motor neumático tiene 1,35 hp, es reversible y puede instalarse tanto desde arriba como desde abajo de la máquina en función de los obstáculos o el modo de servicio.

Eje radial del puente: el eje radial incorpora formas lineales y un husillo a bolas para un recorrido de 13,9" (353 mm). Se puede reposicionar sobre el puente para cortar desde el diámetro exterior máximo hacia el centro cero.

Portaherramientas: el ángulo del cabezal de la herramienta también se puede ajustar 360 grados para avanzar axialmente en un ángulo. La base de la herramienta se puede rotar de forma independiente para mantener la geometría de la herramienta. La posición radial y axial se puede ajustar manualmente utilizando una carraca de 3/8".

Unidad de avance automático: la unidad de avance automático suprime la necesidad de manipular manualmente las manivelas de avance durante el servicio. La Refrentadora Rápida ODF40 incluye cuatro activadores de avance para impulsar la unidad de avance ajustable. El avance se puede ajustar desde 0,001-0,032" (0,03-0,8 mm) por revolución y puede emplearse en cualquiera de los ejes.

Patas de elevación: las patas de elevación han sido diseñadas únicamente para montarse en el diámetro exterior. Las patas de elevación regulables tienen unas garras ajustables y funcionan con las patas de montaje para nivelar la máquina. Consulte el Apartado 3.3 de la página 15 para ver más restricciones dimensionales de montaje.

Accesorio de refrentado posterior: el accesorio de refrentado posterior opcional permite mecanizar cuando hay obstáculos en el puente. También se puede utilizar para mecanizar la parte trasera de las bridas de tubería.

2.2 CONTROLES

Los controles de la Refrentadora Rápida ODF40 se encuentran en la unidad de acondicionamiento neumático (distribuidor neumático), tal como se muestra en la Figura 2-2.



FIGURA 2-2. CONTROLES DEL DISTRIBUIDOR NEUMÁTICO

ADVERTENCIA

Detenga siempre la máquina y bloquee/ señalice el distribuidor neumático antes de realizar ajustes en los controles o en los componentes de la máquina. No seguir estas indicaciones de seguridad puede ocasionar lesiones graves.

Parada de emergencia

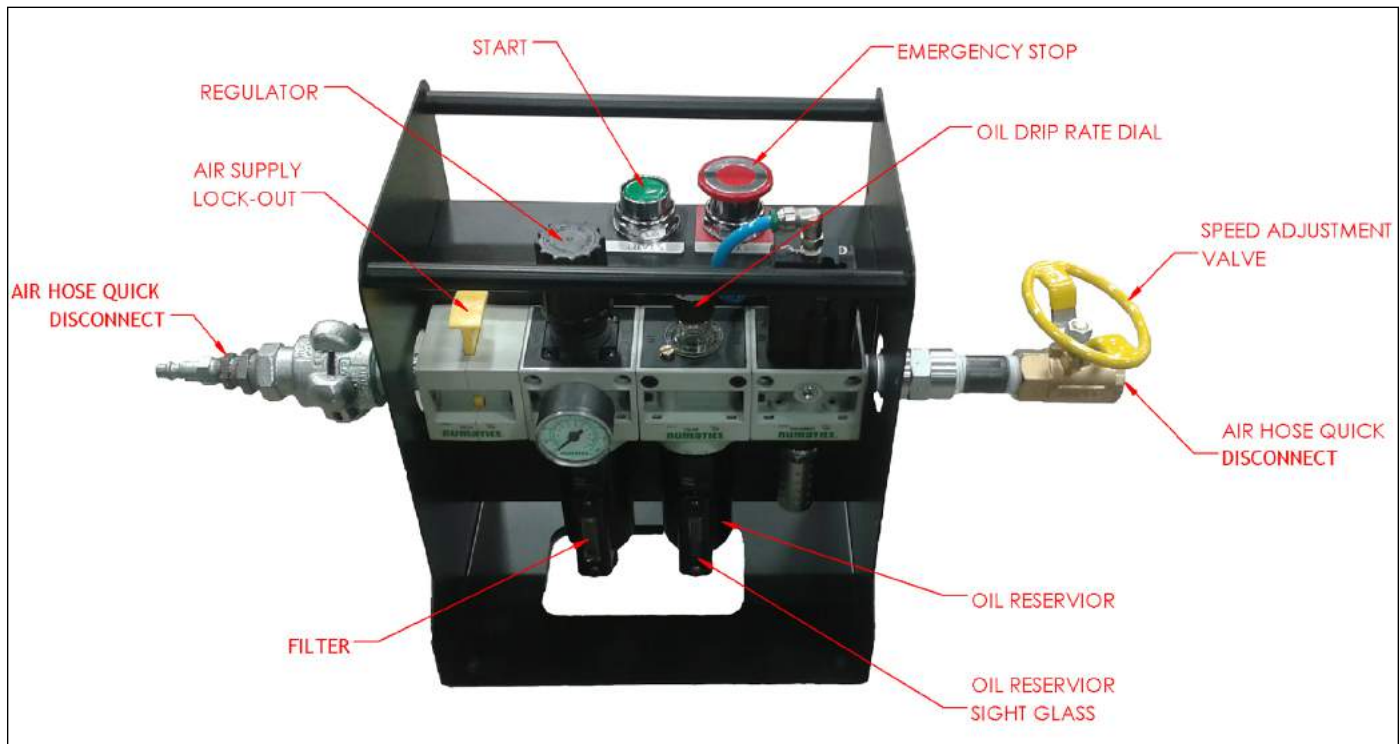
Para detener de inmediato el funcionamiento de la máquina, accione el botón de PARADA DE EMERGENCIA (EMERGENCY STOP) del distribuidor neumático.

Antes de reiniciar la Refrentadora Rápida ODF40, lleve a cabo lo siguiente:

1. Cierre la válvula de ajuste de la velocidad.
2. Levante el botón de PARADA DE EMERGENCIA (EMERGENCY STOP).
3. Accione el botón de ARRANQUE (repita el paso 1 si es necesario).

2.3 DIMENSIONES

La Figura 2-3 muestra las dimensiones operativas de la máquina.



FIGURA 2-3. DIMENSIONES DE LA REFRENTADORA RÁPIDA ODF40 (P/N 86870)

2.4 ESPECIFICACIONES

TABLA 2-1. MASA DE LOS SUBCOMPONENTES

P/N	Componente	Masa en lbs (kg)
87164	Kit de montaje del mandril de expansión (4)	22,5 (10,2) cada uno
87030	Accesorio de refrentado posterior	62 (28)
86877	ODF40 unión soldada del puente	125 (57)
86876	ODF40 contrapeso	65 (30)
86870	Refrentadora Rápida ODF40	1382 (627)

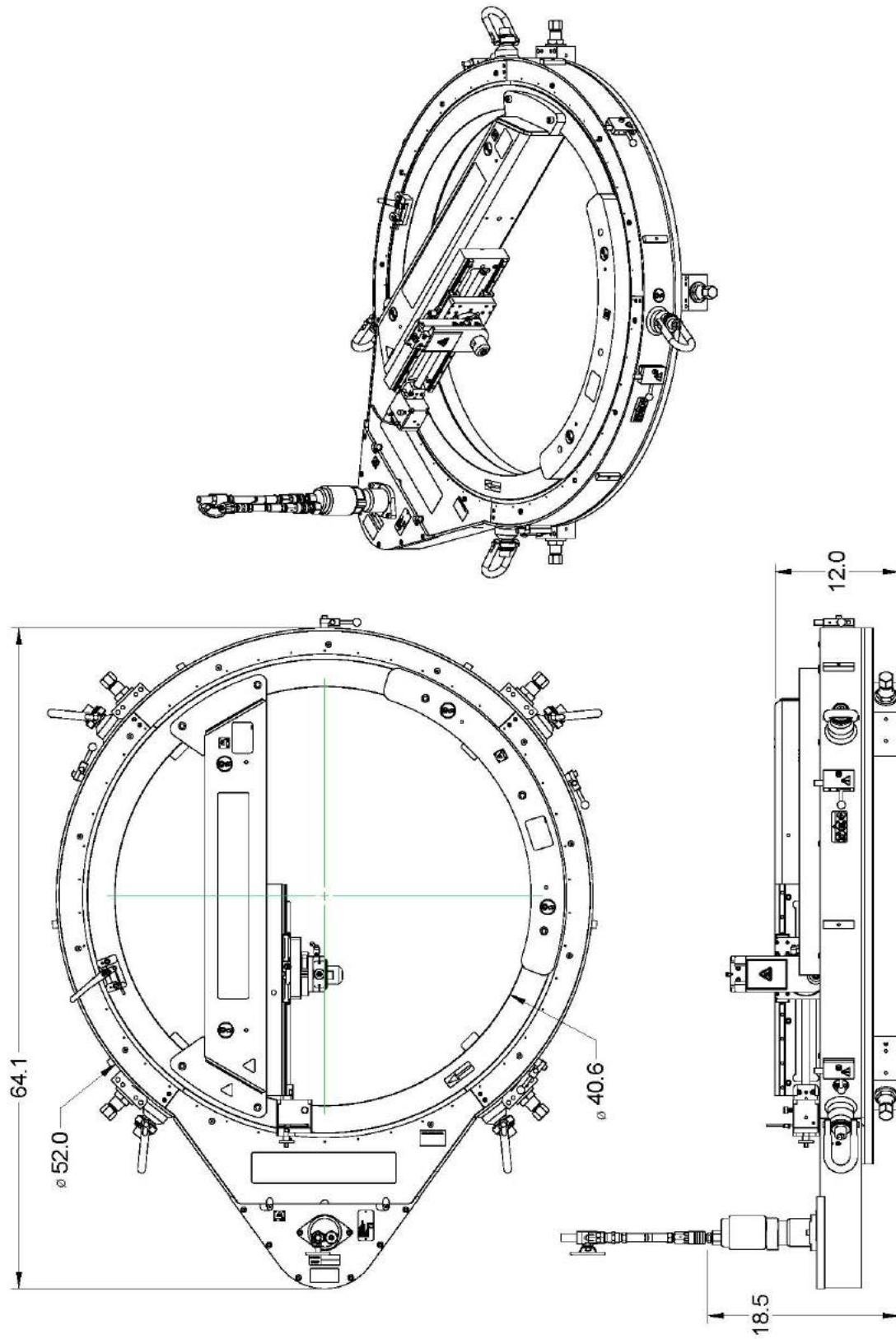
2.5 ELEMENTOS NECESARIOS PERO NO SUMINISTRADOS

Los siguientes elementos se necesitan pero no están incluidos en el kit de producto H&S:

- Llave dinamométrica
- Indicador de dial
- Bloques de madera
- Cinta métrica

3 CONFIGURACIÓN

EN ESTE CAPÍTULO:

3.1 RECEPCIÓN E INSPECCIÓN	13
3.2 SISTEMA DE ELEVACIÓN Y APAREJOS	13
3.3 PELIGROS DURANTE LA INSTALACIÓN	15
3.3.1 MONTAJE HORIZONTAL	16
3.3.2 MONTAJE VERTICAL	16
3.3.3 MONTAJE POR ENCIMA DE LA CABEZA	17
3.4 ENSAMBLAJE DE LA MÁQUINA	17
3.4.1 CENTRADO Y NIVELACIÓN	18
3.4.2 INSTALACIÓN DE LA CUCHILLA O EL CINCEL	19
3.4.3 ROTACIÓN DEL CABEZAL DE LA HERRAMIENTA	20
3.4.4 AJUSTE DEL AVANCE	20
3.4.5 INSTALACIÓN DEL MOTOR DE ACCIONAMIENTO	21
3.4.6 CONEXIÓN DEL DISTRIBUIDOR NEUMÁTICO	21

Esta apartado describe la configuración y el montaje de la Refrentadora Rápida ODF40.

3.1 RECEPCIÓN E INSPECCIÓN

El producto H&S ha sido inspeccionado y comprobado antes de su envío y empaquetado para unas condiciones de transporte normales. H&S no puede garantizar el estado de la máquina hasta que se entrega.

Una vez haya recibido su producto H&S, lleve a cabo las siguientes comprobaciones:

1. Compruebe si los embalajes de envío han sufrido daños.
2. Compruebe el contenido de los embalajes con ayuda del albarán para asegurarse de que ha recibido todos los componentes.
3. Examine todos los componentes en búsqueda de daños.

Póngase inmediatamente en contacto con H&S si detecta daños o falta algún componente.

NOTA

Conserve todos los materiales de embalaje para almacenar y enviar la máquina en el futuro.

La máquina sale de las instalaciones de H&S con una capa pesada de LPS 3. Se recomienda utilizar el limpiador LPS PreSolve Orange Degreaser. Todas las piezas deben haberse limpiado antes del uso.

3.2 SISTEMA DE ELEVACIÓN Y APAREJOS

Antes de desembalar los contenedores de envío, repase la lista de verificación para el análisis de riesgos que hay en la Tabla 1-2 de la página 5.

Antes de elevar la máquina, asegúrese de que todas las piezas están acopladas a la misma de forma segura.

PELIGRO

La Refrentadora Rápida ODF40 puede llegar a pesar hasta 1382 lbs (627 kg) una vez montada. Para evitar que se lesione o lesionen gravemente otras personas, siga siempre las instrucciones de servicio descritas en el presente manual, las normas de su empresa y las disposiciones locales para los trabajos pesados. Si se utilizan métodos de elevación inadecuados las consecuencias pueden ser lesiones graves o incluso la muerte.

Proceda de la siguiente forma para elevar correctamente:

1. Fije cuatro argollas de elevación de 3/4" a la máquina si es que aún no están enganchadas.



FIGURA 3-1. PUNTOS DE ELEVACIÓN (MOSTRADOS EN LA MÁQUINA ODF40)

PRECAUCIÓN

La caída o el balanceo descontrolado de la maquinaria puede ocasionar lesiones graves o incluso la muerte del operador y los observadores. Levante la máquina solo por las argollas de elevación de 3/4" marcadas en la Figura 3-1. No levante la Refrentadora Rápida ODF40 utilizando los puntos de elevación más pequeños situados en el puente o en el contrapeso.

2. Fije el aparejo suministrado por el cliente a las argollas de elevación de la tabla.

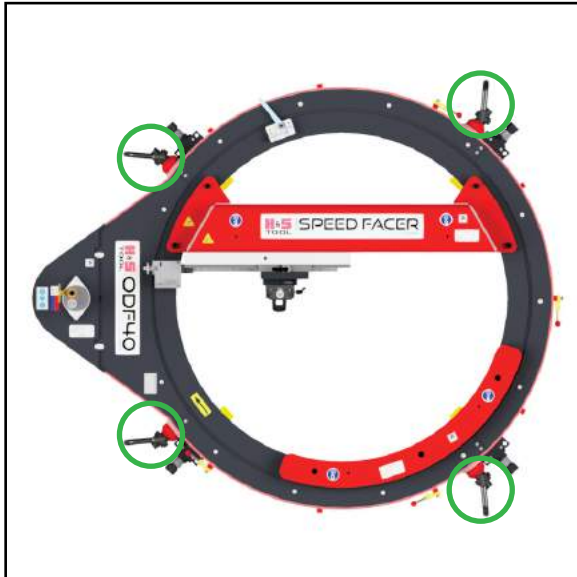
PRECAUCIÓN

Asegúrese de que el aparejo se ha fijado correctamente antes de elevar la máquina. Levante la máquina lentamente asegurándose de que ningún componente quedará aplastado o doblado si la máquina se eleva en posición vertical. Si el aparejo provoca que la máquina oscile o se vuelva inestable, bájela y ajuste el aparejo.

3. Revise la máquina fuera de la caja de envío.

3.3 PELIGROS DURANTE LA INSTALACIÓN

La fase de instalación puede ser peligrosa, ya que se basa en que el operador y el resto del personal sigan las instrucciones de seguridad recomendadas. Tenga especialmente en cuenta las siguientes advertencias de seguridad antes de empezar el montaje.



FIGURA 3-2. PELIGRO VERTICAL

⚠ ADVERTENCIA

Si no se asegura adecuadamente, la máquina puede caerse y causar lesiones mortales al personal. Preste especial atención a la brida vertical y a las instalaciones que se montan por encima de la altura de la cabeza.

Fije todos los componentes a la máquina antes de levantarla. Utilice aparejo adicional durante el ajuste.

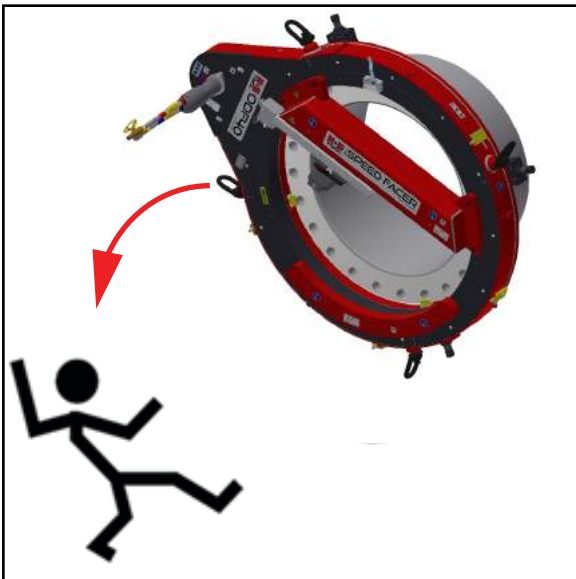

FIGURA 3-3. PREPARATIVOS PARA EL MONTAJE

3.3.1 Montaje horizontal

El peligro de un montaje horizontal es que la máquina se caiga y golpee la soldadura del puente.

Se puede reducir este riesgo mediante una de las siguientes medidas:

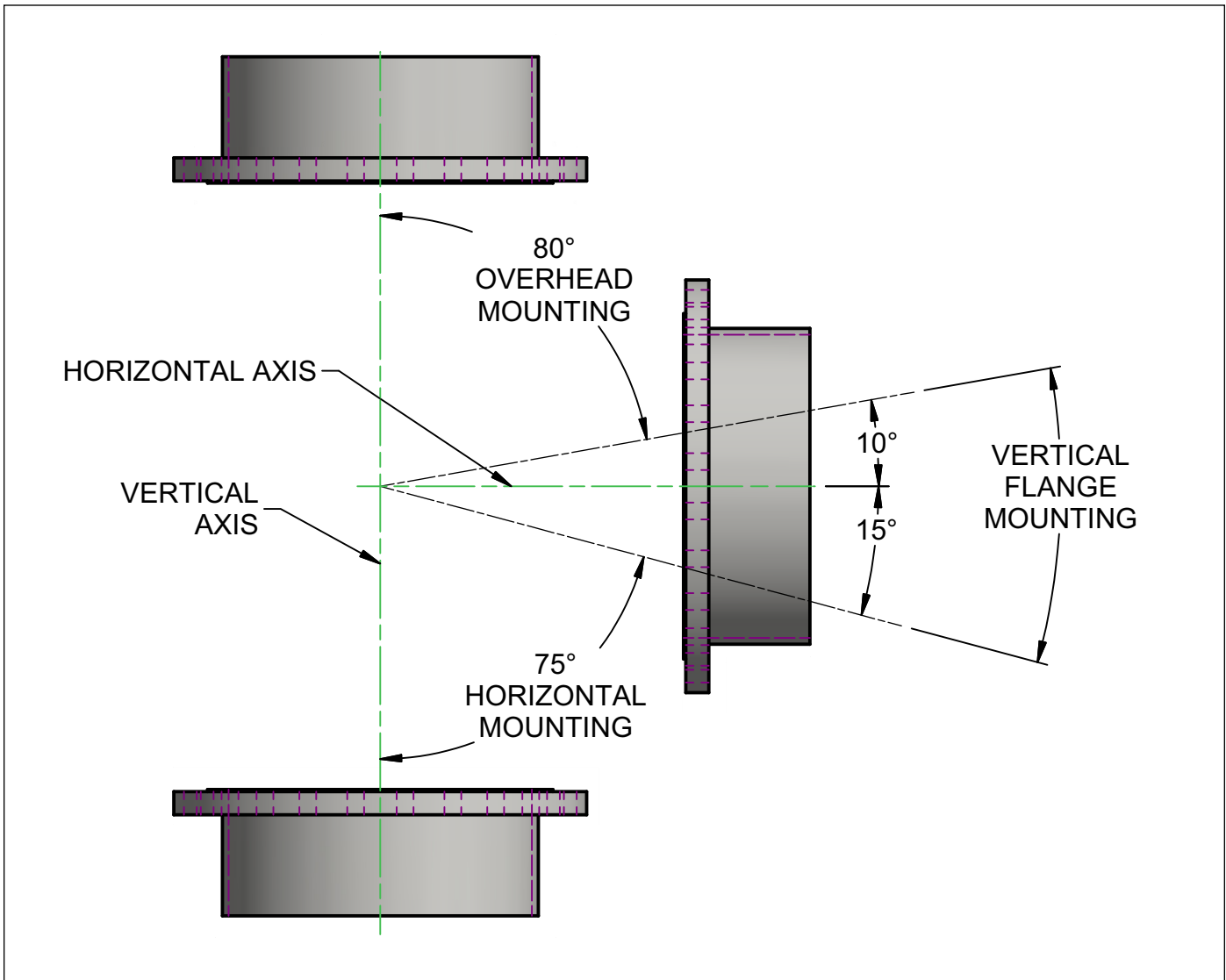
- Deje las patas de montaje en posición encima de las patas regulables.
- Si es necesario retirar las patas de montaje, bloquee la máquina desde abajo o asegure

la máquina a los puntos de anclaje que hay encima utilizando un mínimo de dos argollas de elevación basculantes del lado opuesto con los puntos de anclaje y eslingas suministrados por el cliente específicos para el peso de la máquina y el ángulo de oscilación. Vea la Figura 3-3.

3.3.2 Montaje vertical

El peligro de un montaje vertical es que la máquina se caiga de la brida.

Se puede reducir este riesgo mediante una de las siguientes medidas:

- Instale las patas de montaje en la parte posterior de la brida, en la «parte inferior» de las patas regulables (vea la Figura 3-4).



FIGURA 3-4. ORIFICIO DE MONTAJE ALTERNADO

- Si la brida es demasiado gruesa para poder utilizar las patas de montaje, bloquee la máquina desde abajo o asegure la máquina a los puntos de anclaje que hay encima utilizando un mínimo de una argolla de elevación basculante con los puntos de anclaje y eslingas suministrados por el cliente específicos para el peso de la

máquina y el ángulo de oscilación. Vea la Figura 3-3.

3.3.3 Montaje por encima de la cabeza

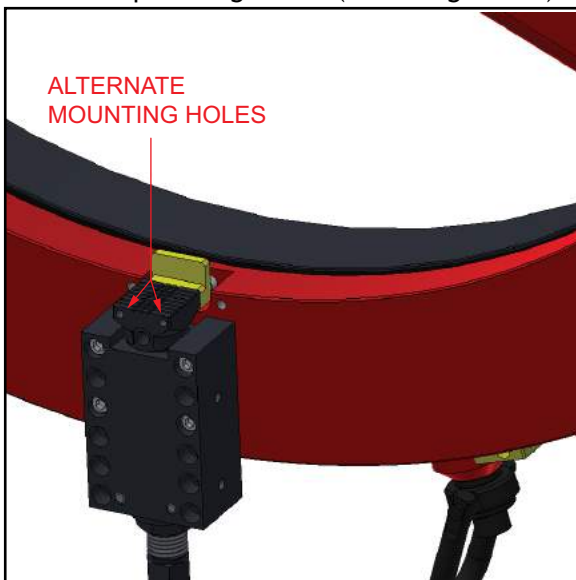
El peligro de un montaje por encima de la cabeza es que la máquina se caiga de la brida.

Se puede reducir este riesgo mediante una de las siguientes medidas:

- Instale las patas de montaje en la parte posterior (arriba) de la brida, en la «parte inferior» de las patas regulables (vea la Figura 3-4).
- Si la brida es demasiado gruesa para poder utilizar las patas de montaje, bloquee la máquina desde abajo o asegure la máquina a los puntos de anclaje que hay encima utilizando un mínimo de dos argollas de elevación basculantes en el lado opuesto con los puntos de anclaje y eslingas suministrados por el cliente específicos para el peso de la máquina y el ángulo de oscilación. Vea la Figura 3-3.

PRECAUCIÓN

Estas medidas de seguridad deben tenerse en cuenta en todos los casos durante el análisis de riesgos y el sistema de retención de la máquina debe ajustarse de forma que cualquier oscilación o movimiento de la máquina se mantiene reducido al mínimo.

3.4 ENSAMBLAJE DE LA MÁQUINA

Lleve a cabo lo siguiente para ajustar la Refrentadora Rápida ODF40:

1. Repase la lista de verificación para el análisis de riesgos que hay en la Tabla 1-2 de la página 5.
2. Mida el diámetro exterior de la brida que desea mecanizar.

3. Coloque la máquina sobre una base sólida para instalar las cuatro patas de montaje conforme a la Tabla 3-1.

ADVERTENCIA

La máquina podría desplazarse o caerse si se monta y fija de forma incorrecta.



FIGURA 3-5. PERNOS Y ORIFICIOS

TABLA 3-1. PATAS DE MONTAJE OD40

Diámetro exterior mín. en pulgadas (mm)	Diámetro exterior máx. en pulgadas (mm)	Ubicación perno base	Ubicación orificio bastidor
37,02 (940)	40,5 (1.029)	D	1
35,02 (889)	38,5 (978)	C	1
33,02 (839)	36,5 (927)	C	2
31,02 (788)	34,5 (876)	B	2
29,02 (737)	32,5 (826)	A	2

4. Centre la garra de nivelación y conexión con el cilindro de nivelación y conexión en los conjuntos de patas regulables.
5. Ajuste de forma aproximada las patas regulables (tal como se muestra en la Figura 3-6) girando la tuerca de conexión hasta que sobresalga aproximadamente 1/8" (3 mm) del diámetro exterior de la brida.

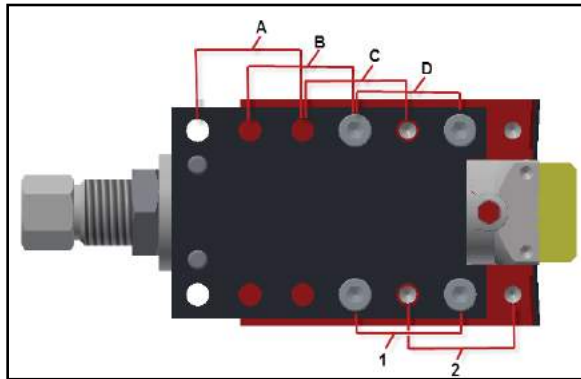

FIGURA 3-6. COMPONENTES DE LA PATA REGULABLE

NOTA

Las garras de regulación y las garras estándar solo tienen una trayectoria de 1,7" (43 mm).

6. Coloque la máquina sobre la brida situando las patas de montaje frente a la superficie de la brida de unión.
7. Apriete las tuercas de las patas regulables de forma homogénea hasta que las garras estén frente al diámetro exterior de la brida con un par de apriete de 10 ft-lbs (14 Nm).

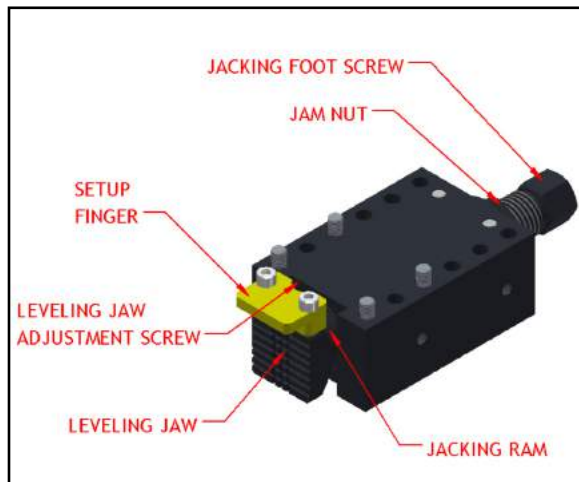
3.4.1 Centrado y nivelación

Lleve a cabo lo siguiente para centrar y nivelar la máquina:

1. Para un ajuste aproximado, compruebe la distancia entre el diámetro interior de la máquina y el diámetro exterior de la tubería con una cinta métrica en las cuatro patas regulables.
2. Para un ajuste fino, utilice un indicador de dial en el portaherramientas para comprobar las mismas mediciones entre el diámetro interior de la máquina y el diámetro exterior de la tubería. El ajuste se realiza en ambos casos con las tuercas de la pata regulable en altura.
3. Cuando las patas de montaje alcancen la altura inicial, haga lo siguiente para ajustar el nivel:
 - a) Instale un indicador de dial en el portaherramientas centrado sobre la superficie elevada de la brida.
 - b) Ponga a cero el indicador encima de la primera pata regulable y gire la máquina 180° para posicionar el indicador en línea con la pata opuesta.
 - c) Eleve o baje la garra la mitad de la diferencia entre las dos patas mediante el tornillo de ajuste de la garra de nivelación.
 - d) Repita el paso b y paso c en las patas regulables restantes. Las aplicaciones habituales requieren el alineamiento de

la máquina dentro de 0,010" (0,25 mm) o menos.



FIGURA 3-7. INDICADOR DE DIAL MONTADO PARA NIVELACIÓN

4. Aplique un par de apriete de 60 ft-lbs (81 Nm) alternando entre las cuatro patas de elevación ajustable.

⚠ ADVERTENCIA

Asegúrese de apretar las patas de elevación a 60 ft-lbs (81 Nm) como mínimo. Si la fuerza de sujeción es insuficiente la máquina puede caerse de la pieza de trabajo y dañarse o provocar lesiones o incluso la muerte.

NOTA

No apriete en exceso las tuercas de las patas de elevación. Apretar en exceso podría deformar el bastidor rotacional de la máquina y producir resultados de mecanizado no deseados.

5. Apriete las contratuercas de todas las patas de elevación.
6. Si es necesario, retire las patas de montaje de las patas regulables para mecanizar completamente hasta el diámetro exterior. Vea los subapartados del Apartado 3.3 de la página 15 para más información sobre cómo bloquear la máquina.

3.4.2 Instalación de la cuchilla o el cincel

NOTA

La Refrentadora Rápida ODF40 ha sido diseñada para seguir la herramienta de corte detrás de la soldadura del puente. La soldadura del puente gira en el sentido de las manillas del reloj, tal como se muestra desde el lado de la máquina en el que la soldadura del puente está fijada. Recuerde estas características cuando instale una nueva herramienta en la máquina.

Haga lo siguiente para instalar la cuchilla o el cincel:

1. Ajuste el portaherramientas a la posición correcta para iniciar el mecanizado.
2. Ajuste el portaherramientas a la posición correcta para iniciar el mecanizado (vea la Figura 3-8).



FIGURA 3-8. UBICACIÓN DE LA TUERCA DE SUJECIÓN OSCILANTE

3. Para instalar la herramienta adecuada en la base de la herramienta oscilante: Afloje el tornillo de sujeción M20, inserte la herramienta de corte y apriete el tornillo M20.

CONSEJO:

Inserte siempre la herramienta de corte tan lejos como sea posible dentro del portaherramientas para una buena estabilidad.

4. Ajuste la herramienta a la profundidad de corte deseada.

3.4.3 Rotación del cabezal de la herramienta

Lleve a cabo lo siguiente para ajustar el cabezal de la herramienta:

1. Afloje los dos tornillos de sujeción para liberar la abrazadera circular en la parte posterior del cabezal de la herramienta.

PRECAUCIÓN

No afloje rápidamente el cabezal de la herramienta. Mantenga la mano apoyada sobre el cabezal de la herramienta para estabilizarlo. Retirar rápidamente el cabezal de la herramienta puede provocar que oscile de forma inesperada y ocasionar daños personales o en la máquina.

2. Posicione el cabezal de la herramienta.
3. Bloquee la abrazadera apretando los dos tornillos de sujeción oscilantes.

Las marcas grabadas sobre la abrazadera permite ángulos de ajuste dentro de $\pm 0,5^\circ$.

3.4.4 Ajuste del avance

NOTA

La unidad de avance se puede colocar tanto en el deslizamiento radial como axial en función de si el proceso de mecanizado se trata de un refrentado o una perforación.

Lleve a cabo lo siguiente para ajustar el avance:

1. Instale los activadores de avance de la forma requerida (vea la Figura 3-9).



FIGURA 3-9. UBICACIÓN DEL ACTIVADOR DE AVANCE

CONSEJO:

El número de activadores de avance determina la tasa de avance y el tiempo de acabado deseado. Se incluyen cuatro activadores de avance. La caja de alimentación se puede ajustar a partir de 0,001-0,008" (0,003-0,2 mm) de revolución por trayecto. Los acabados más finos suelen utilizar uno o dos activadores con el avance ajustado en un valor reducido por trayecto. Los acabados bastos o rápidos utilizan los cuatro activadores de avance.

2. Fije la dirección de avance conforme a los siguientes pasos, tal como se muestra en la Figura 3-10:
 - a) Presione el botón de dirección de avance para dirigir el avance hacia el centro.
 - b) Tire del botón de dirección de avance para dirigir el avance hacia el diámetro exterior.

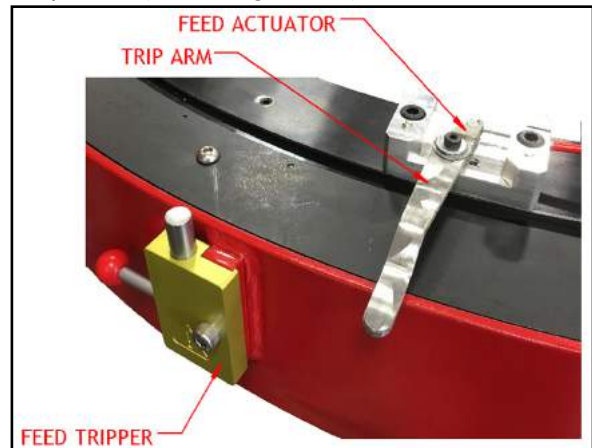
CONSEJO:

Puede ser necesario girar ligeramente el botón cuando se cambia la dirección de avance.



FIGURA 3-10. AJUSTES DE AVANCE

3. Ajuste la cantidad de material por recorrido.

NOTA

Cuando el tornillo de regulación de avance está desenroscado hasta la cantidad máxima, el avance se encuentra en la cantidad máxima de aproximadamente 0,008" (0,2 mm) por recorrido. Cuando el tornillo de regulación de avance está enroscado, el avance se encuentra en el mínimo. Al ajustar el tornillo moleteado, se cambia el ángulo del brazo de recorrido en el actuador de avance.

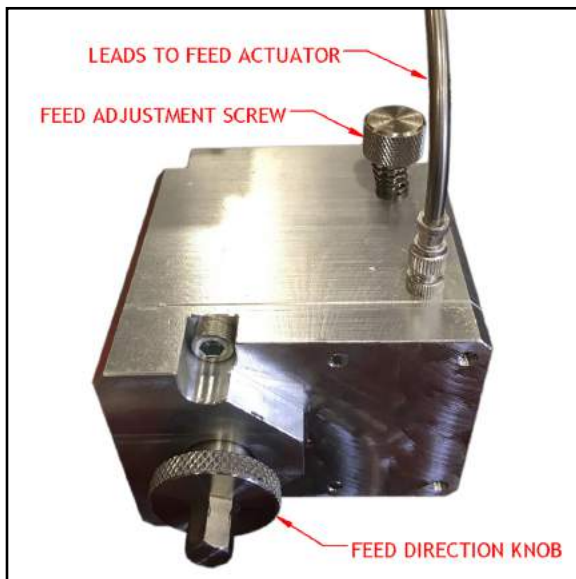
4. Trace y fije el cable de alimentación para evitar que se doble o quede atrapado entre los obstáculos.

3.4.5 Instalación del motor de accionamiento

Las etiquetas rojo-azules (P/N 60219, 60220 mostradas en la Tabla 1-4 de la página 6) en cada lado de la máquina donde está instalado el motor neumático indican la disposición de los conductos para que el motor avance en la dirección correcta.

Por ejemplo, cuando el motor está instalado en la parte superior, el conducto rojo conecta con el puerto rojo del motor. Vea la Figura 3-11.



FIGURA 3-11. MOTOR NEUMÁTICO INSTALADO

Haga lo siguiente para instalar el motor de accionamiento:

1. Compruebe que la llave esté insertada en la ranura del eje del motor.
2. Encaje el eje de accionamiento del motor en el buje de accionamiento alineando la llave con la ranura en el buje de accionamiento.
3. Apriete los dos tornillos de la abrazadera de montaje para fijar.

3.4.6 Conexión del distribuidor neumático

Conecte el distribuidor neumático a la máquina desconectando la válvula de ajuste de velocidad.

Esta página ha sido intencionalmente dejada en blanco

4 SERVICIO

EN ESTE CAPÍTULO:

4.1 COMPROBACIONES PREVIAS AL SERVICIO	23
4.2 MODOS DE SERVICIO	23
4.2.1 CONFIGURACIÓN PARA REFRENTAR BRIDAS	23
4.2.2 CONFIGURACIÓN PARA AVELLANAR	24
4.2.3 INSTALACIÓN DEL ACCESORIO DE REFRENTADO POSTERIOR	24
4.3 SERVICIO	25
4.3.1 ARRANQUE DE LA MÁQUINA	25
4.3.2 DETENCIÓN DE LA MÁQUINA	26
4.3.3 CONFIGURACIÓN DE LA MÁQUINA	26

4.1 COMPROBACIONES PREVIAS AL SERVICIO

Compruebe lo siguiente antes de utilizar la máquina:

1. Repase la lista de verificación para el análisis de riesgos que hay en la Tabla 1-3 de la página 5.
2. Asegúrese de que el área de trabajo está despejada de personal y equipamiento no esencial.
3. Asegúrese de que la unidad de control o el área de observación de la máquina no se halle en la trayectoria de las virutas calientes que salen despedidas durante el funcionamiento.
4. Compruebe que la máquina está acoplada de forma segura a la pieza de trabajo conforme al Apartado 3.3 de la página 15.
5. Compruebe que los conductos neumáticos estén tendidos y sujetos para evitar tropiezos, enredos, daños por virutas calientes u otros daños.
6. Compruebe el estado y el filo de la herramienta.
7. Compruebe que la velocidad de goteo de aceite en el distribuidor neumático esté ajustado a seis gotas por minuto.
8. Compruebe que todas las herramientas manuales se hayan retirado del interior de la máquina y del área de trabajo.

4.2 MODOS DE SERVICIO

La Refrentadora Rápida ODF40 puede refrentar, ranurar o biselar bridas planas o cónicas. Los siguientes subapartados describen cómo configurar la máquina para estos modos de servicio. Vea el Apartado 2.2 de la página 10 para más información sobre los controles.

4.2.1 Configuración para refrentar bridas

El refrentado plano es el modo de servicio predeterminado de la Refrentadora Rápida ODF40.

ADVERTENCIA

No configure o ajuste la dirección de mecanizado a menos que la máquina esté desconectada, se haya desconectado el conducto neumático y se haya ejecutado cualquier bloqueo/señalización necesario.

Para configurar la Refrentadora Rápida ODF40 para refrentar una brida plana, complete los siguientes pasos:

1. Acople la Refrentadora Rápida ODF40 a la pieza de trabajo (vea el Apartado 3.3 de la página 15).

2. Revise todas las comprobaciones previas al servicio (vea el Apartado 4.1).
3. Afloje los dos tornillos de bloqueo de la cuña radial y axial.



FIGURA 4-1. TORNILLOS DE BLOQUEO DE CUÑA

4. Utilice una carraca de 3/8" en los tornillos de avance radial y axial para posicionar la herramienta de corte en el punto donde se iniciará el corte.
5. Apriete a mano solo el tornillo de bloqueo de cuña axial.
6. Gire el botón de dirección de avance (vea la Figura 4-4 de la página 25) a la dirección deseada.
7. Ajuste la tasa de avance, consulte el Apartado 3.4.4 de la página 20 y utilice el tornillo de regulación de avance de la caja de alimentación.

4.2.2 Configuración para avellanar

Haga lo siguiente para poder avellanar:

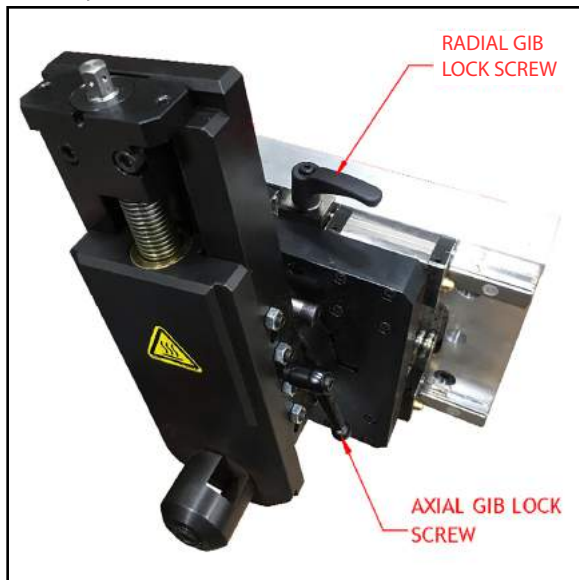
1. Acople la Refrentadora Rápida ODF40 a la pieza de trabajo (vea el Apartado 3.2 de la página 13).
2. Revise todas las comprobaciones previas al servicio (vea el Apartado 4.1).
3. Reposicione la caja de alimentación desde el tornillo de avance radial al tornillo de avance axial y bloquéela con los dos tornillos.
4. Afloje los dos tornillos de bloqueo de la cuña axial y radial.

5. Utilice una carraca de 3/8" en los tornillos de avance radial y axial para posicionar la herramienta de corte en el punto donde se iniciará el corte.
6. Apriete a mano solo el tornillo de bloqueo de cuña radial.
7. Gire el botón de dirección de avance a la dirección deseada. Si se presiona el botón de dirección de avance en esta configuración, la cuchilla se aparta del operador.
8. Ajuste la tasa de avance, consulte el Apartado 3.4.4 de la página 20 y utilice el tornillo de regulación de avance de la caja de alimentación.

4.2.3 Instalación del accesorio de refrentado posterior

La Refrentadora Rápida ODF40 también se puede configurar con el accesorio de refrentado posterior opcional. Esta configuración permite refrentar bridas cuando hay obstrucciones que recorren la tubería y también mecanizar el lado posterior de la brida de unión.

Haga lo siguiente para configurar la máquina para el refrentado posterior:

1. Retire la soldadura del puente y el contrapeso de la máquina. Tenga en cuenta las masas indicadas y utilice métodos de elevación y traslado adecuados como los descritos en el Apartado 3.2 de la página 13.



FIGURA 4-2. COMPONENTES PARA EL REFRENTADO POSTERIOR

2. Retire la corredera radial de la soldadura del puente e instálela en la placa de montaje de refrentado posterior.

3. Instale la soldadura de montaje angular en la máquina mediante los orificios para los pernos específicos del modelo.

4. Instale la corredera axial en la soldadura de montaje angular.

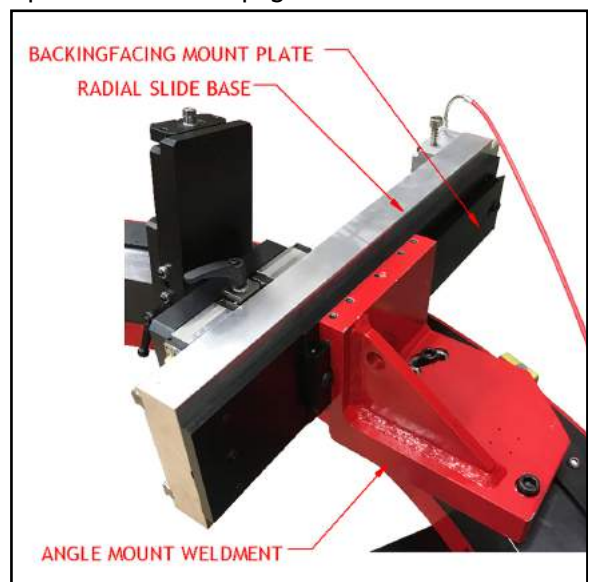
4.3 SERVICIO



FIGURA 4-3. CONTROLES DEL DISTRIBUIDOR NEUMÁTICO

4.3.1 Arranque de la máquina

Haga lo siguiente para arrancar la máquina:

1. Complete estos pasos en el distribuidor neumático (como se muestra en la Figura 4-3):
 - a) Abra la válvula de CORTE DE SUMINISTRO DE AIRE (AIR SUPPLY LOCK-OUT).
 - b) Tire del botón de PARADA DE EMERGENCIA (EMERGENCY STOP).
 - c) Presione el botón de ARRANQUE.
 - d) Abra lentamente la válvula de AJUSTE DE VELOCIDAD (SPEED ADJUSTMENT) hasta alcanzar la velocidad de rotación deseada.

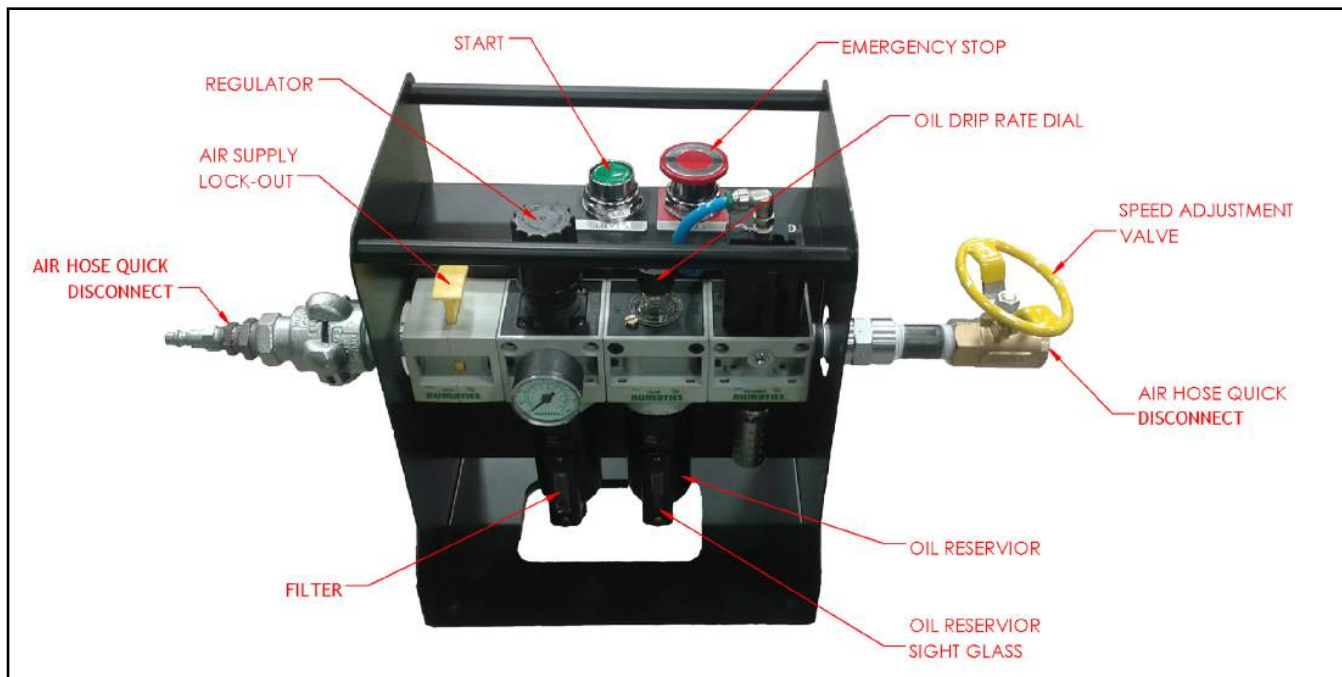
2. Utilice el número de activadores de avance necesarios para el tipo de acabado (vea el Apartado 3.4.4 de la página 20).



FIGURA 4-4. TORNILLO DE REGULACIÓN DE AVANCE Y BOTÓN DE DIRECCIÓN DE AVANCE

3. Para ajustar la tasa de avance: detenga la máquina (vea el Apartado 4.3.2 de la página 26), luego afine el tornillo de regulación de avance en base a la velocidad del corte inicial.
4. Ajuste la tasa de avance y la velocidad de rotación necesaria para mantener el corte deseado.
5. Ajuste la velocidad de goteo de aceite necesaria (vea la Figura 4-3).

NOTA

Para mejorar el rendimiento y la vida útil de la máquina, H&S recomienda una velocidad de goteo de aceite mínima en el distribuidor neumático de seis gotas por minuto.

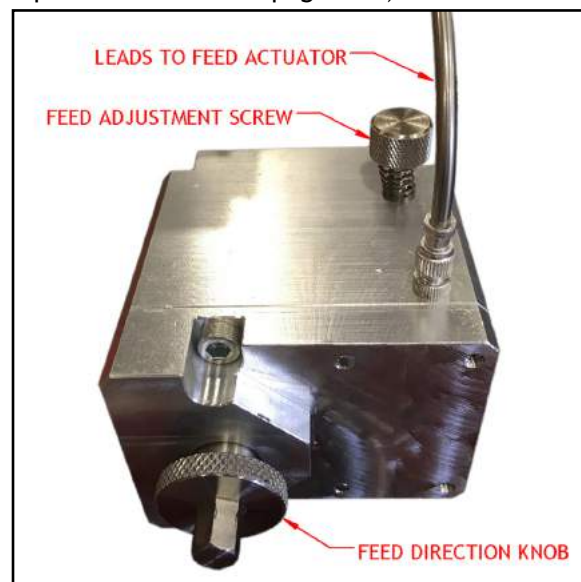
4.3.2 Detención de la máquina

Haga lo siguiente para detener la Refrentadora Rápida ODF40:

1. Desconecte los activadores de avance (vea la Figura 3-9 de la página 20).
2. Gire la válvula de AJUSTE DE VELOCIDAD (SPEED ADJUSTMENT) en sentido horario para cerrarla.

3. Presione la válvula de CORTE DE SUMINISTRO DE AIRE (AIR SUPPLY LOCK-OUT) para cerrarla (como se muestra en la Figura 4-3). De esta forma se expulsa la presión de aire residual existente en el circuito del distribuidor neumático.

4.3.3 Configuración de la máquina

Lleve a cabo lo siguiente para ajustar manualmente la posición o el ángulo de la herramienta de corte:

1. Desconecte los activadores de avance (vea la Figura 4-4).
2. Detenga y bloquee la máquina (vea el Apartado 4.3.2).
3. Ajuste manualmente la posición o el ángulo de la herramienta de corte (vea el Apartado 3.4.1 de la página 18 y el Apartado 3.4.2 de la página 19).

ADVERTENCIA

No intente ajustar manualmente el ángulo de la herramienta de corte o cambiar los ajustes de la caja de alimentación durante el funcionamiento. Intentar manejar los controles de la caja de alimentación con la mano o con herramientas manuales mientras la máquina está en funcionamiento puede causar lesiones graves.

5 MANTENIMIENTO

EN ESTE CAPÍTULO:

5.1 LISTA DE VERIFICACIÓN PARA EL MANTENIMIENTO	-27
5.2 LUBRICANTES AUTORIZADOS	-27
5.3 TAREAS DE MANTENIMIENTO	-28
5.3.1 VERIFICACIÓN DE LA RESERVA DE ACEITE DEL DISTRIBUIDOR NEUMÁTICO Y DEL FILTRO COLECTOR DE PARTÍCULAS	-28
5.3.2 VERIFICACIÓN DEL CIRCUITO DE GOTEO DEL DISTRIBUIDOR NEUMÁTICO	-29
5.3.3 COMPROBACIÓN DE LA PARADA DE EMERGENCIA	-29
5.3.4 GUÍAS DE COLA DE MILANO	-29
5.3.4.1 GUÍAS DE COLA DE MILANO RADIALES	-29
5.3.4.2 GUÍAS DE COLA DE MILANO AXIALES	-29
5.3.5 INSTALACIÓN Y ELIMINACIÓN DE PROTECCIONES	-29
5.3.6 AJUSTE DEL RODILLO	-30
5.4 RESOLUCIÓN DE AVERÍAS	-31
5.4.1 LA MÁQUINA NO GIRA	-31
5.4.2 LA MÁQUINA NO AVANZA	-31
5.4.3 LA MÁQUINA NO FUNCIONA BIEN	-31
5.4.4 LA MÁQUINA NO CORTA PLANO	-31

5.1 LISTA DE VERIFICACIÓN PARA EL MANTENIMIENTO

Tabla 5-1 listas de intervalos y tareas de mantenimiento

TABLA 5-1. INTERVALOS Y TAREAS DE MANTENIMIENTO

Intervalo	Tarea	Referencia
Antes de cada uso	Compruebe la reserva de aceite del distribuidor neumático y el filtro colector de partículas.	5.3.1
	Compruebe que los conductos neumáticos no estén dañados ni desgastados.	--
	Compruebe que la herramienta de corte esté afilada. Sustitúyala si es necesario.	5.4.3
	Compruebe el circuito de goteo del distribuidor neumático	5.3.2
Antes de cada uso	Elimine los restos, el aceite y la humedad de las superficies.	--
Cada diez ciclos de trabajo	Lubrique las guías de cola de milano radiales y axiales.	5.3.4

5.2 LUBRICANTES AUTORIZADOS

H&S recomienda los siguientes lubricantes en los puntos indicados.

Emplear un lubricante inadecuado puede ocasionar daños y el desgaste prematuro de la máquina.

PRECAUCIÓN

Utilice únicamente los lubricantes autorizados para evitar daños en la máquina, el desgaste prematuro de la misma y para no perder la garantía.

TABLA 5-2. LUBRICANTES AUTORIZADOS

Área de lubricación	Lubricante	Lubricante biodegradable	Viscosidad (cSt)	Cantidad	Frecuencia
Diaria					
Guías de cola de milano rectangulares ^a	Aceite pesado Mobil Vactra Oil	N/A	>68 @ 40C	Según sea necesario	Diariamente durante el uso de la máquina
En cada uso					
Distribuidor neumático	Unax AW 32	N/A	22-68 @ 40 °C 4,3-8,7 @ 100 °C	Rellenar el lubricador de aceite	En cada uso
Superficies sin pintar	LPS1 o LPS2	N/A	38 @ 25C	Según sea necesario	En cada uso y antes de almacenar
Semanalmente					
Husillo de fricción sobre el punto único del cabezal de la herramienta	Lubricante en espray NOOK E-100 Grasa NOOK PAG-1	CASTROL BioTac EP 2	96 @ 40C 113 @ 100C	Capa delgada aplicada a mano o con espray	Semanalmente durante el uso de la máquina
Patas de elevación	Moly Grade antiadherente	N/A	N/A	1 cc por tornillo	Semanalmente durante el uso de la máquina y antes del almacenamiento
Anualmente					
Superficie de apoyo del anillo de seguimiento	LPS multiusos clase Platinum	N/A	N/A	Según sea necesario	Semanalmente durante el uso de la máquina

a. Utilice aceite mineral o sintético refinado altamente anticorrosivo capaz de formar una película de aceite resistente que no emulsione fácilmente y sea difícil de eliminar con refrigerante. Los aceites hidráulicos no suelen ser apropiados para lubricar correderas.

5.3 TAREAS DE MANTENIMIENTO

Las tareas de mantenimiento se describen en el apartado siguiente.

5.3.1 Verificación de la reserva de aceite del distribuidor neumático y del filtro colector de partículas

Haga lo siguiente para comprobar la reserva de aceite del distribuidor neumático y el filtro colector de partículas:

1. Compruebe la reserva de aceite del distribuidor neumático a través de la mirilla (vea la Figura 4-3 de la página 25). Rellénela si es necesario.

2. Compruebe el filtro colector de partículas del distribuidor neumático a través de la mirilla. Vacíelo si es necesario.

5.3.2 Verificación del circuito de goteo del distribuidor neumático

El circuito de goteo del distribuidor neumático evita que la máquina se reinicie de forma accidental después de perder y restaurar el suministro de aire del distribuidor neumático.

Haga lo siguiente para comprobar el circuito de goteo del distribuidor neumático:

1. Compruebe que el distribuidor neumático esté conectado al suministro de aire del taller y a la Refrentadora Rápida ODF40.
2. Compruebe que el cierre del suministro de aire esté abierto (es decir, levantado). Vea la Figura 4-3 de la página 25.
3. Presione el botón de ARRANQUE.
4. Abra lentamente el ajuste de velocidad del distribuidor neumático hasta alcanzar la velocidad de rotación deseada.
5. Cierre la válvula de CORTE DE SUMINISTRO DE AIRE (AIR SUPPLY LOCK-OUT) (presionándola hacia abajo).
6. Compruebe que la Refrentadora Rápida ODF40 se detiene.
7. Abra la válvula de CORTE DE SUMINISTRO DE AIRE (AIR SUPPLY LOCK-OUT).
8. Compruebe que la máquina no arranque.

5.3.3 Comprobación de la parada de emergencia

Haga lo siguiente para comprobar la parada de emergencia:

1. Con la máquina en funcionamiento, presione el botón de PARADA DE EMERGENCIA (EMERGENCY STOP).
2. Compruebe que la máquina se detenga.
3. Reinicie el botón de PARADA DE EMERGENCIA (EMERGENCY STOP) tirando de él.
4. Compruebe que la máquina no arranque de nuevo.

5.3.4 Guías de cola de milano

5.3.4.1 Guías de cola de milano radiales

Haga lo siguiente para llevar a cabo el mantenimiento de las guías de cola de milano radiales:

1. En el montaje por deslizamiento, utilice el tornillo de avance radial para mover el cabezal de la herramienta a un extremo de la pista de avance radial.
2. Pase un trapo por las guías de cola de milano expuestas y lubríquelas con aceite Mobil VACTRA medium heavy way oil o similar.
3. Mueva el conjunto del cabezal de la herramienta al otro extremo de la pista de avance radial.
4. Pase un trapo por las guías de cola de milano expuestas restantes y lubríquelas con aceite Mobil VACTRA medium heavy way oil o similar.

5.3.4.2 Guías de cola de milano axiales

Haga lo siguiente para llevar a cabo el mantenimiento de las guías de cola de milano axiales:

1. En el montaje de la corredera, utilice el tornillo de avance axial para mover el cabezal de la herramienta a un extremo de la pista de avance axial.
2. Pase un trapo por las guías de cola de milano expuestas y lubríquelas con aceite Mobil VACTRA medium heavy way oil o similar.
3. Mueva la corredera de la herramienta al otro extremo de la pista de avance axial.
4. Pase un trapo por las guías de cola de milano expuestas restantes y lubríquelas con aceite Mobil VACTRA medium heavy way oil o similar.

5.3.5 Instalación y eliminación de protecciones

Haga lo siguiente para retirar las protecciones para realizar tareas de mantenimiento:

1. Desenrosque todos los tornillos M8 hasta que queden sueltos.
2. Localice un tornillo M8 central cerca de una de las secciones de protección.
3. Coloque el extremo cerrado de una llave de estrella de 9/16 encima de la cabeza del tornillo con un ángulo que la fije contra la protección.



FIGURA 5-1. LLAVE DE ESTRELLA ENCIMA DEL TORNILLO

4. Tire rápidamente de la llave hacia arriba para retirar la protección.
5. Repita el paso 2 hasta el paso 4 para retirar las secciones de protección restantes.

Una vez realizado el trabajo de mantenimiento, haga lo siguiente para instalar la protección:

1. Si no se han extraído aún, retire todos los tornillos M8 de las secciones de protección.
2. Coloque la primera de las secciones de protección en la posición más adecuada de la máquina.
3. En el centro de la protección, inserte dos punzones de 3/16" (o similar) a través de los orificios de la protección en los puntos mostrados a continuación. En las máquinas grandes este proceso puede ser necesario iniciarlo en un extremo y no en el centro.



FIGURA 5-2. PUNZONES UTILIZADOS PARA LA INSTALACIÓN DE PROTECCIONES

4. Empuje los punzones hacia el interior de la máquina y tire de la protección para encajarla. Al mismo tiempo, golpee el frente de la protección con un martillo de goma.

5. Repita los pasos 2-4 para las secciones de protección restantes.
6. Vuelva a colocar y apretar todos los tornillos M8.

5.3.6 Ajuste del rodillo

Mientras la máquina está en funcionamiento, cada rodillo debe girar aproximadamente dos tercios del tiempo. Si los rodillos están demasiado apretados, la máquina se frenará. El ajuste ideal permite que la máquina gire con la fuerza de la mano.

⚠ ADVERTENCIA

El ajuste de los rodillos requiere que la máquina funcione sin la protección en su sitio. No intente nunca ajustar los rodillos cuando la máquina esté en rotación, ya que podría causar lesiones graves o la muerte.

Lleve a cabo lo siguiente para ajustar los rodillos:

1. Retire todas las protecciones. (Vea el Apartado 5.3.5 de la página 29.)
2. Arranque la máquina y llévela a la velocidad de servicio máxima.
3. Compruebe qué rodillos no están girando debidamente.
4. Detenga la máquina y presione la válvula de corte de suministro de aire.
5. Coloque la llave de ajuste del rodillo (vea la Figura 5-3) encima del husillo excéntrico y suelte el tornillo de bloqueo con una llave Allen de 5/16". Ajuste el husillo excéntrico hasta que el rodillo apenas toque la ranura en la corona dentada.



FIGURA 5-3. LLAVE DE AJUSTE DEL RODILLO (P/N 86988)

6. Apriete el tornillo de bloqueo mientras se mantiene la posición del husillo excéntrico con la llave de ajuste.
7. Vuelva a comprobar la máquina a plena velocidad.
8. Aplique una capa de producto antideslizante sobre la superficie del cojinete de la corona dentada de la forma descrita en la figura 5-2.
9. Sustituya todas las protecciones.

5.4 RESOLUCIÓN DE AVERÍAS

Este apartado pretende ayudar a resolver los problemas de funcionamiento básicos de la máquina. Para un mantenimiento profesional o si tiene preguntas sobre los siguientes procedimientos, póngase en contacto con H&S.

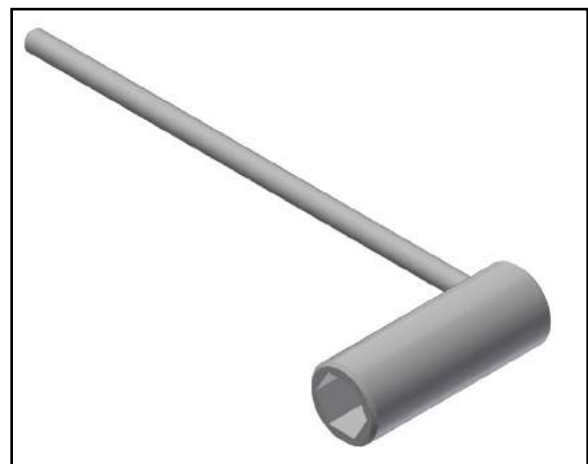
5.4.1 La máquina no gira

Si la máquina no gira, compruebe lo siguiente:

1. La fuente de energía está conectada y encendida.
2. La PARADA DE EMERGENCIA (EMERGENCY STOP) se ha reiniciado (Apartado 4.3.1 de la página 25 y Apartado 5.3.3 de la página 29).
3. El regulador de aire está abierto y no está roto (Figura 4-3 de la página 25).
4. Hay presión de aire entrando y saliendo del distribuidor neumático. Compruebe la presión de aire desconectando las desconexiones rápidas de tubo flexible y comprobando la purga de aire (Figura 4-3 de la página 25).
5. Todas las válvulas están abiertas (Figura 4-3 de la página 25).
6. Todas las desconexiones rápidas están completamente acopladas (Figura 4-3 de la página 25).
7. Compruebe el movimiento de la máquina verificando primero que la fuente de alimentación hacia el accionamiento de la máquina esté aislado y bloqueado, luego gire la máquina manualmente mediante las asas de la soldadura del puente.

5.4.2 La máquina no avanza

Si la máquina no avanza adecuadamente, compruebe lo siguiente:

1. Los activadores de avance están acoplados (Apartado 3.4.4 de la página 20).
2. El botón de dirección de avance está más bien hundido o levantado y no en una posición central neutral.

5.4.3 La máquina no funciona bien

Si la máquina no funciona bien, compruebe lo siguiente:

1. La herramienta está correctamente instalada (Apartado 3.4.2 de la página 19).
2. Compruebe que la máquina esté ajustada a la pieza de trabajo (Apartado 3.3 de la página 15).
3. Los tornillos de la soldadura del puente están bloqueados.
4. Los tornillos de retención de las correderas axial y radial están correctamente ajustados (Apartado 4.2.1 de la página 23 y Apartado 4.2.2 de la página 24).
5. Los tornillos de sujeción oscilantes del cabezal de la herramienta rotativa están ajustados (Apartado 3.4.1 de la página 18).
6. La herramienta de corte o el accesorio de corte está afilado y tiene la geometría correcta para el material y el tipo de corte.
7. La velocidad y la tasa de avance están correctamente fijadas. Si es necesario, pruebe con distintas velocidades y tasas de avance. Normalmente una velocidad baja y cortes poco profundos producen menos vibraciones en la herramienta.

5.4.4 La máquina no corta plano

Si la máquina no corta plano, haga lo siguiente:

1. Antes de dar un paso final crítico, mantenga la máquina en marcha de forma continua durante al menos 15 minutos para asegurarse de que la máquina alcanza la temperatura adecuada para funcionar.
2. Compruebe la máquina para nivelar (Apartado 3.4.1 de la página 18).
3. Desplace lo necesario el portaherramientas al frente de la brida (Apartado 3.4.1 de la página 18).

Esta página ha sido intencionalmente dejada en blanco

6 ALMACENAMIENTO Y ENVÍO

EN ESTE CAPÍTULO:

6.1 ALMACENAMIENTO	33
6.1.1 ALMACENAMIENTO BREVE	33
6.1.2 ALMACENAMIENTO PROLONGADO	33
6.2 ENVÍO	34
6.3 DESGUACE	34

6.1 ALMACENAMIENTO

ADVERTENCIA

Si no se asegura adecuadamente, la máquina puede caerse y causar lesiones mortales al personal. Preste especial atención a la brida vertical y a las instalaciones que se montan por encima de la altura de la cabeza.

La máquina debe estar correctamente fijada y asegurada a una grúa o a un equipo de elevación adecuado antes de comenzar cualquier trabajo de desmontaje.

Si la Refrentadora Rápida ODF40 se almacena adecuadamente se alargará su vida útil y se evitarán daños injustificados.

Antes de almacenar, haga lo siguiente:

1. Limpie la máquina con disolvente para eliminar la grasa, las virutas de metal y la humedad.
2. Purgue todos los líquidos de la unidad de acondicionamiento neumático.

Almacene la Refrentadora Rápida ODF40 en su embalaje original. Conserve todos los materiales de embalaje para empaquetar la máquina.

6.1.1 Almacenamiento breve

Haga lo siguiente para un almacenamiento breve (inferior a tres meses):

1. Retire el cabezal de la herramienta de la pieza de trabajo.
2. Retire las herramientas.
3. Retire los tubos flexibles.
4. Retire la máquina de la pieza de trabajo.
5. Limpie la máquina para eliminar la suciedad, la grasa, las virutas de metal y la humedad.
6. Rocíe todas las superficies sin pintar con LPS-2 para prevenir la corrosión.
7. Almacene la Refrentadora Rápida ODF40 en su caja original (vea la Figura 6-1).

6.1.2 Almacenamiento prolongado

Haga lo siguiente para un almacenamiento prolongado (superior a tres meses):

1. Siga las instrucciones de almacenamiento breve, pero utilice LPS-3 en lugar de LPS-2.
2. Introduzca una bola secante en el contenedor de envío. Reemplácela conforme a las instrucciones del fabricante.
3. Almacene el contenedor de envío en un entorno fuera del alcance de la radiación solar directa a una temperatura < 70 °F (21 °C) y humedad < 50 %.

6.2 ENVÍO

La Refrentadora Rápida ODF40 se puede enviar en su contenedor de envío original de la forma descrita en Figura 6-1.



FIGURA 6-1. CAJA ODF40

6.3 DESGUACE

Para desguazar la Refrentadora Rápida ODF40 antes de desecharla, retire el accionamiento y elimínelo de forma separada del resto de los componentes de la máquina. Consulte el Appendix A para más información acerca de los componentes.

APÉNDICE A DIBUJOS DE MONTAJE

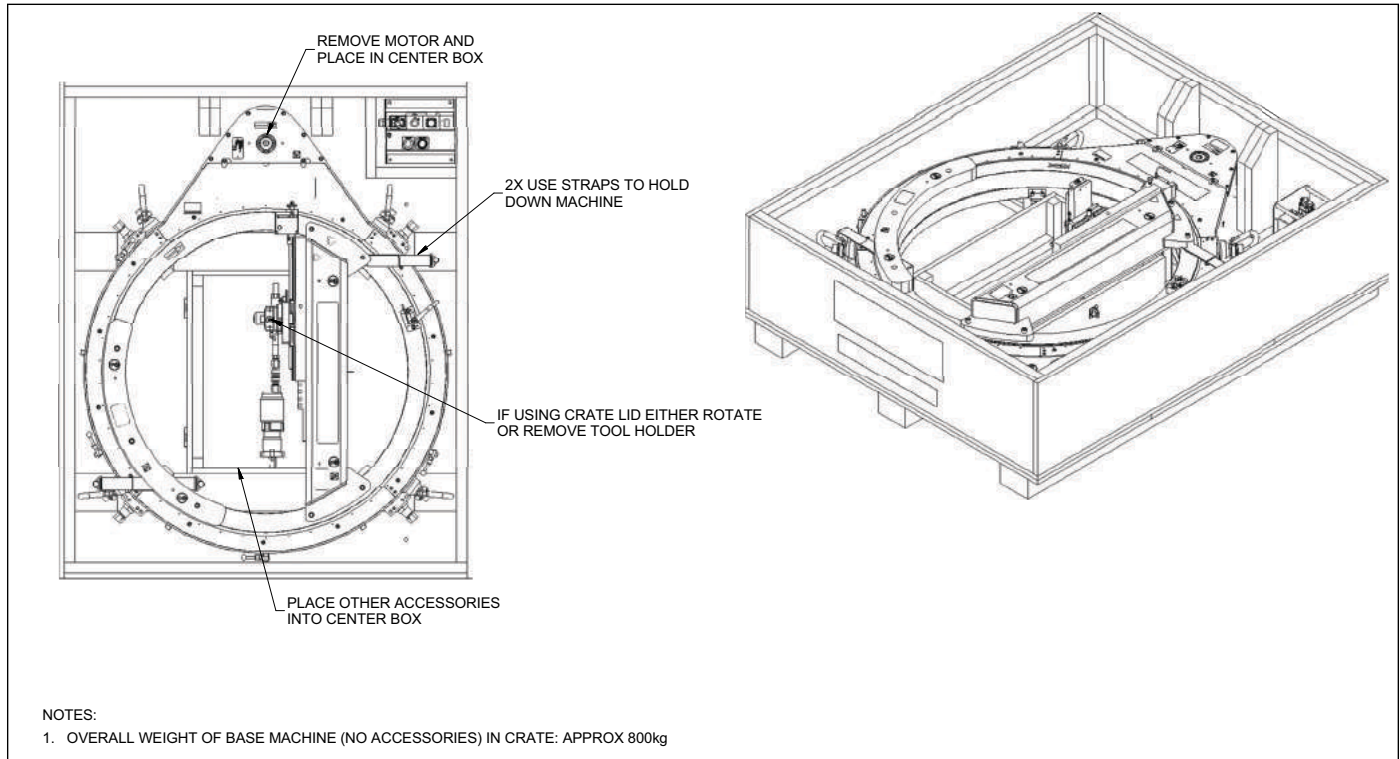
Lista de dibujos

FIGURA A-1. MONTAJE DE LA REFRENTADORA RÁPIDA ODF40 (P/N 86870) - - - - -	-36
FIGURA A-2. MONTAJE DE LAS ETIQUETAS DE LA REFRENTADORA RÁPIDA ODF40 (P/N 86870) - - - - -	-37
FIGURA A-3. LISTA DE PIEZAS DE LA REFRENTADORA RÁPIDA ODF40 (P/N 86870) - - - - -	-38
FIGURA A-4. MONTAJE DEL PORTAHERRAMIENTAS DE LA CORREDERA (P/N 79790) - - - - -	-39
FIGURA A-5. LISTA DE PIEZAS DEL PORTAHERRAMIENTAS DE LA CORREDERA (P/N 79790) - - - - -	-40
FIGURA A-6. MONTAJE DE LA UNIDAD DE ACONDICIONAMIENTO NEUMÁTICO (P/N 83430) - - - - -	-41
FIGURA A-7. MONTAJE DE LA UNIDAD DE ACONDICIONAMIENTO NEUMÁTICO (P/N 83430) - - - - -	-42
FIGURA A-8. MONTAJE DE NIVELACIÓN DE LAS PATAS DE ELEVACIÓN (P/N 86880) - - - - -	-43
FIGURA A-9. MONTAJE DEL EJE RADIAL (P/N 86890) - - - - -	-44
FIGURA A-10. LISTA DE PIEZAS DE MONTAJE DEL EJE RADIAL (P/N 86890) - - - - -	-45
FIGURA A-11. MONTAJE DE LA CAJA DE ALIMENTACIÓN DEL CABLE DE TRACCIÓN (P/N 86900) - - - - -	-46
FIGURA A-12. ACTUADOR DE AVANCE EN EL MONTAJE DE LA CAJA DE ALIMENTACIÓN DEL CABLE DE TRACCIÓN (P/N 86900) - - - - -	-47
FIGURA A-13. MONTAJE DEL ACTIVADOR DE AVANCE (P/N 86910) - - - - -	-48
FIGURA A-14. MONTAJE DEL MOTOR DE ACCIONAMIENTO (P/N 86989) - - - - -	-49
FIGURA A-15. MONTAJE DE LA PATA DE PROLONGACIÓN (P/N 87164) - - - - -	-50
FIGURA A-16. MONTAJE DEL ACCESORIO DE REFRENTADO POSTERIOR (P/N 87310) - - - - -	-51
TABLA A-1. KIT DE HERRAMIENTAS P/N 78530 - - - - -	-52



FIGURA A-1. MONTAJE DE LA REFRENTADORA RÁPIDA ODF40 (P/N 86870)



FIGURA A-2. MONTAJE DE LAS ETIQUETAS DE LA REFRENTADORA RÁPIDA ODF40 (P/N 86870)

PARTS LIST				PARTS LIST			
ITEM	QTY	P/N:	DESCRIPTION	ITEM	QTY	P/N:	DESCRIPTION
1	2	10445	FTG PLUG 1/4 NPTM SOCKET	31	1	86876	COUNTERWEIGHT SF40
2	2	10453	SCREW 3/8-16 X 1-1/4 SHCS	32	1	86877	WELDMENT BRIDGE ODF40
3	26	10557	SCREW 3/8-16 X 2 SHCS	33	26	86878	ROLLER W4
4	14	10588	SCREW DRIVE #2 X 1/4 HOLE SIZE .089	34	26	86879	BUSHING ECCENTRIC SIZE 4
5	1	15079	WASHER THRUST 1.000 ID X 1.562 OD X .030	35	4	86880	ASSY JACKING FOOT LEVELING
6	2	16111	BRG BALL 1.7717 ID X 2.9528 OD X .6299 SEALS	36	1	86889	IDLER TAKE UP ODF DRIVE
7	26	19236	WASHER 3/8 FLTW HARDENED	37	1	86890	ASSY RADIAL AXIS 356MM TRAVEL
8	1	20956	BLOCK ADJUSTING	38	1	86894	SHEAVE SIZE B 2 GROOVE 8.35 OD QD BORE
9	4	22814	RING HOIST 3/4-10 X 1-1/2 5000 LB	39	1	86897	RING SNAP 1.937 OD X .031 SINGLE TURN SPIRAL
10	3	29152	PLATE MASS CE	40	1	86900	ASSY FEEDBOX PULL CABLE
11	1	30207	SCREW M12 X 1.75 X 35mm SHCS	41	129	86901	SEAL STRIP .062" THICK X 3/8" WIDE
12	7	35215	SCREW M12 X 1.75 X 40mm SHCS	42	4	86910	ASSY FEED TRIPPER
13	6	50458	SCREW M8 X 1.25 X 20mm SHCS	43	1	86972	SHAFT ODF DRIVE
14	8	59039	LABEL WARNING LIFT POINT ROUND 1.5"	44	1	86989	ASSY ODF DRIVE MOTOR
15	1	59042	LABEL WARNING - HAND CRUSH/MOVING PARTS	45	1	86998	PLATE TAKE UP ODF DRIVE
16	1	60219	LABEL HOSE CONNECT SCHEME RED-RED/BLUE-BLUE	46	1	87008	BUSHING QD SK 1-15/16
17	1	60220	LABEL HOSE CONNECT SCHEME BLUE-RED/RED-BLUE	47	2	87020	SCREW M8 X 1.25 X 15MM BHCS CAPTIVE 10 THD STAINLESS
18	1	62978	WASHER M12 FLTW 27MM OD 3.1 MM THICK				
19	2	67743	RING SNAP 2.0 ID X .062 TH	48	1	87022	SCREW 1 DIA X 1.5 X 3/4-10 SHLDCS
20	2	67910	BRG BALL 1.000 ID X 2.000 OD X .500 2 SEALS	49	1	87222	(NOT SHOWN) CRATE ODF40 59 X 71 X 21-1/4 3/4 PLY
21	1	78530	(NOT SHOWN) TOOL KIT SF SERIES	50	1	87259	LABEL H&S ODF40 LOGO 3.0 X 20.0
22	1	79324	LABEL WARNING - HAND ENTANGLEMENT/ROTATING	51	1	87265	LABEL ARROW BLK/YEL 1" X 3"
23	2	79385	GEARS 1.13 TALL TRIANGLE YELLOW	52	1	87269	PLATE SERIAL YEAR MODEL BLANK CE 1.5 X 3.0
24	1	79635	LABEL WARNING - LIFT SUB ASSY ONLY GRAPHIC 2 X 3	53	1	87271	LABEL WARNING - EYE EAR MANUAL PROTECTION 1-3/8 X 2-3/4
25	1	79790	SCREW 3/4-10 X 4 SSSFP				
26	1	83430	ASSY SLIDE TOOL HOLDER	54	1	87272	LABEL MADE IN THE U.S.A 1.5" X 2.5"
27	2	84856	(NOT SHOWN) PNEUMATIC CONDITIONING UNIT WSHEET	55	1	87427	LABEL H&S ODF40 LOGO 3.0 X 14.0
28	1	86371	METAL STAND	56	13	87473	SCREW M8 X 1.25 X 25MM BHCS CAPTIVE 10 THD STAINLESS
29	1	86872	LABEL DANGER - ODF TETHER MACHINE BEFORE USE	57	1	87518	GUARD AND SEAL ASSY SF40
30	2	86874	FRAME WELDMENT SF40	58	13	87519	POST 17MM HEX X 62MM M8 X 1.25 TAPPED AND THRD EACH END
			RING TRACK SF40	59	1	87520	PLATE COVER DRIVE ODF40
			BELT V B164	60	2	87521	CLIP RETAINER

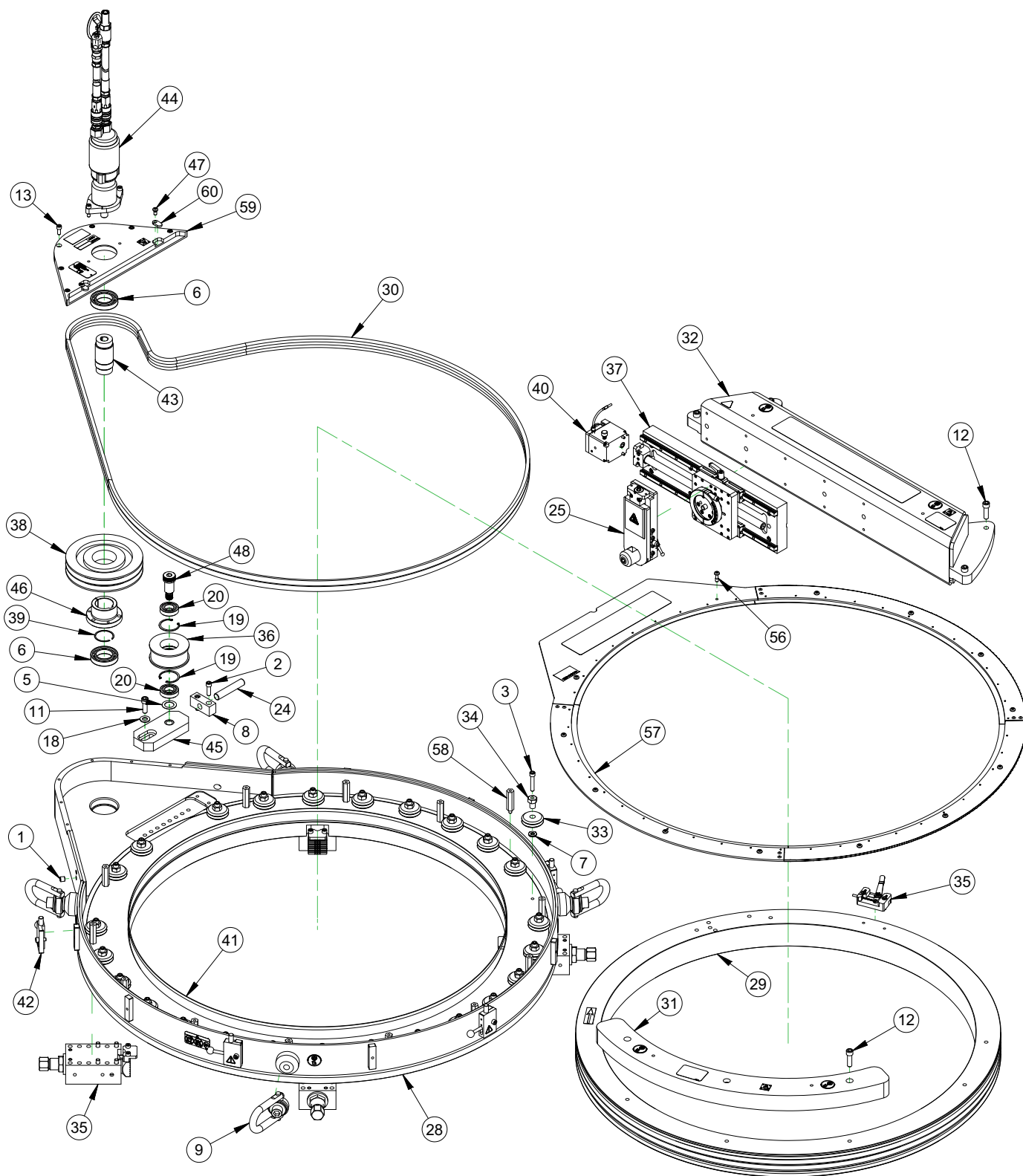
FIGURA A-3. LISTA DE PIEZAS DE LA REFRENTADORA RÁPIDA ODF40 (P/N 86870)

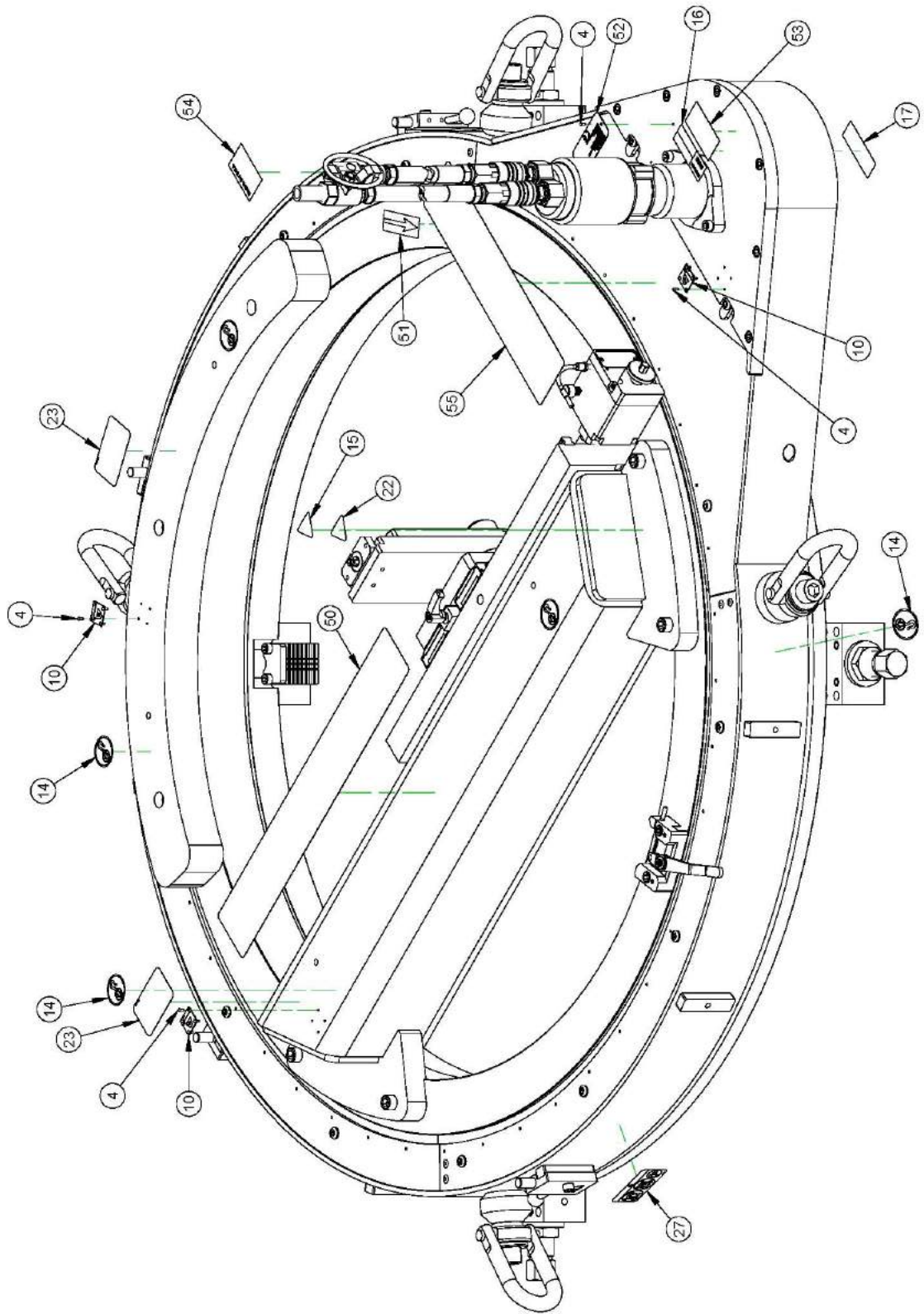

FIGURA A-4. MONTAJE DEL PORTAHERRAMIENTAS DE LA CORREDERA (P/N 79790)

PARTS LIST			
ITEM	QTY	P/N:	DESCRIPTION
1	4	10436	WASHER THRUST .500 ID X .937 OD X .060
2	2	10437	BRG THRUST .500 ID X .937 OD X .0781
3	2	16953	PIN DOWEL 3/16 DIA X 5/8
4	4	20772	NUT M6 X 1.0 STDN ZINC PLATED
5	4	35014	SCREW M6 X 1.0 X 16mm SHCS
6	2	35505	SCREW M6 X 1.0 X 30 SHCS
7	2	43489	BALL NYLON 1/8 DIA
8	1	45034	SCREW M6 X 1.0 X 12MM SSSDPPL
9	1	46902	LABEL WARNING HOT SURFACE GRAPHIC 1.13" TALL
10	1	48526	NUT LEADSCREW ACME 3/4-10 BRONZE LH
11	2	53365	SCREW M4 X 0.7 X 4 mm SSSFP
12	1	57214	BRG RETAINING NUT AXIAL FEED LEADSCREW
13	2	57320	RING O 1/16 X 13/16 ID X 15/16 OD
14	1	57793	BEARING BLOCK LEADSCREW
15	1	57912	LEAD SCREW AXIAL FEED FF LINE
16	1	58133	HANDLE ADJUSTABLE M6 X 1 X 20MM
17	2	59003	SCREW M6 X 1.0 X 14MM SHCS
18	4	74658	SCREW M6 X 1 X 25MM SSSDP
19	1	79548	BASE TOOL HOLDER
20	1	79826	PLATE DOVE CIRCULAR
21	1	80307	TOOL HEAD TOP SLIDE
22	1	80309	CLAMP TOOL BIT 3/4 SQ
23	AR	80419	(NOT SHOWN) SHIM 1.8 ID X 3.2 OD .001 THICK
24	AR	80420	(NOT SHOWN) SHIM 1.8 ID X 3.2 OD .002 THICK
25	AR	80421	(NOT SHOWN) SHIM 1.8 ID X 3.2 OD .005 THICK
26	1	82224	GIB TOOLHEAD
27	1	82280	SCREW M20 X 2.5 X 25MM SSSDP

FIGURA A-5. LISTA DE PIEZAS DEL PORTAHERRAMIENTAS DE LA CORREDERA (P/N 79790)

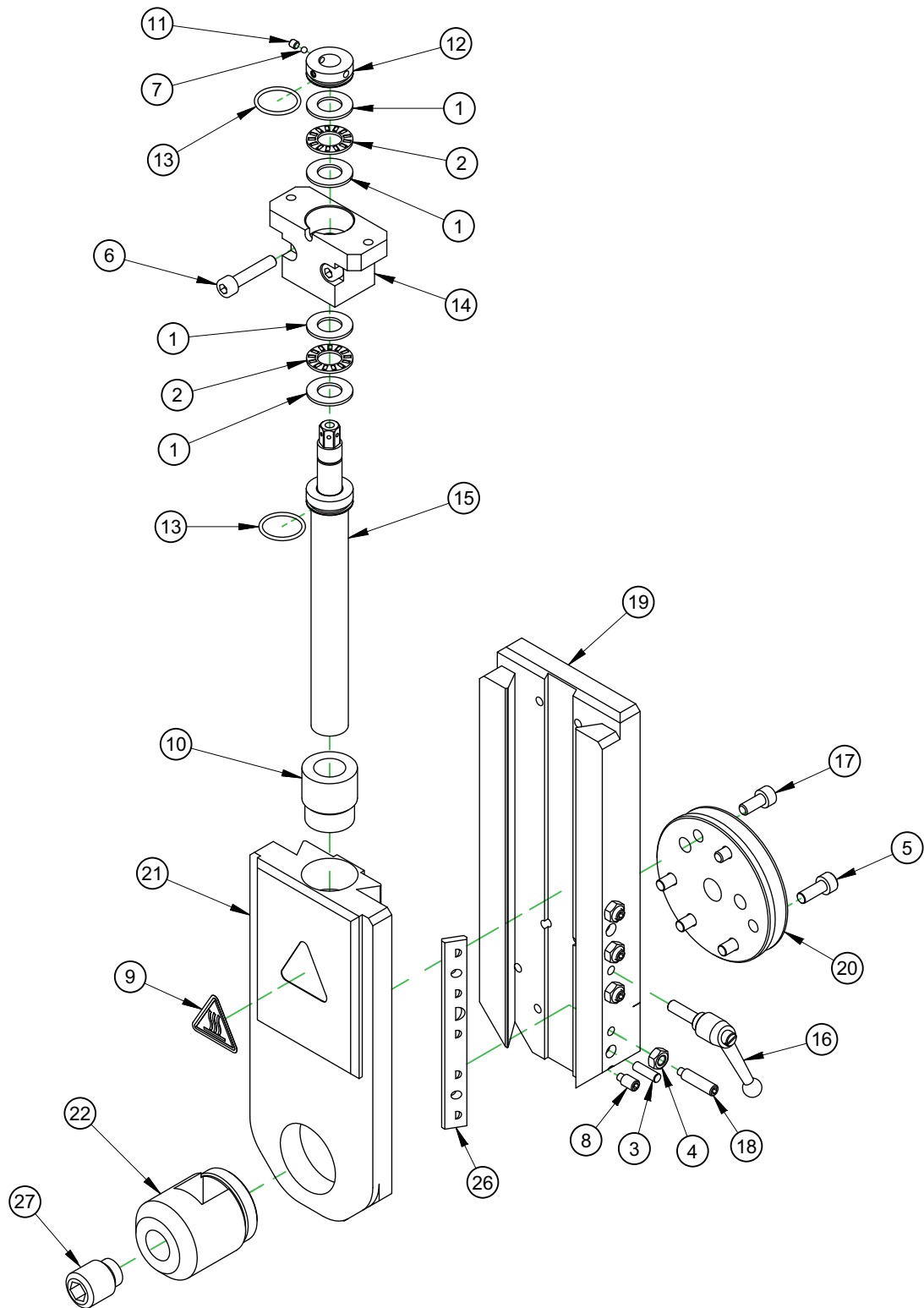

FIGURA A-6. MONTAJE DE LA UNIDAD DE ACONDICIONAMIENTO NEUMÁTICO (P/N 83430)

PARTS LIST			
ITEM	QTY	P/N:	DESCRIPTION
1	1	10223	FTG NIPPLE CLOSE 1/2 NPTM X 1/2 NPTM 125 PSI 1-1/8 LONG
2	1	10319	FTG COUPLING 1/2 NPTF X 1/2 NPTF STEEL ZINC PLATED
3	4	11315	WASHER #10 FLTW BLACK OXIDE
4	1	14726	SCREW 10-32 X 1/4 SHCS
5	5	22235	FTG BARB #10-32 X 1/8 HOSE
6	1	40588	GROMMET 5/8 OD 5/16 ID
7	1	46768	LUBRICATOR AIR 1/2 NPTF 3.8OZ BOWL W/SIGHT
8	1	46769	VALVE EXHAUST QUICK PILOT 1/2NPTF MUFFLER
9	1	46777	VALVE SHUT OFF VS22 SERIES
10	2	46785	VALVE PUSHBUTTON 5 PORT PNEUMATIC
11	1	46797	LEGEND PLATE START 10250 SERIES
12	3	48648	FTG ELBOW 1/8 NPTM X 1/4 TUBE PRESTOLOK
13	28	48650	(NOT SHOWN) TUBING 1/4 OD POLYURETHANE
14	6	53617	SCREW M5 X 0.8 X 12MM BHCS BLACK FINISH
15	4	56357	SCREW 10-24 X 2.5 SHCS
16	3	59442	RING O 2mm X 23mm ID X 25mm OD
17	1	59458	PUSHBUTTON GREEN FLUSH
18	1	59459	PUSH BUTTON PUSH PULL MAINTAINED (M-M)
19	1	59462	PUSH BUTTON OPERATOR RED 1-5/8
20	1	59825	LEGEND PLATE STOP 10250SERIES YELLOW BACKGROUND
21	1	78054	FILTER/REGULATOR PARTICULATE 1/2NPTF METAL BOWL GLASS
22	1	81132	LABEL WARNING - INSERT SAFETY LOCK
23	4	83462	RUBBER BUMPER, 9/16 DIA X 1/8 TALL
24	1	83486	PRESSURE GAUGE, 0-160 PSI, 1/8 NPT CENTER BACK MOUNT
25	1	87223	STAND PCU
26	4	87533	NUT 10-24 STDNYLOC SS

FIGURA A-7. MONTAJE DE LA UNIDAD DE ACONDICIONAMIENTO NEUMÁTICO (P/N 83430)

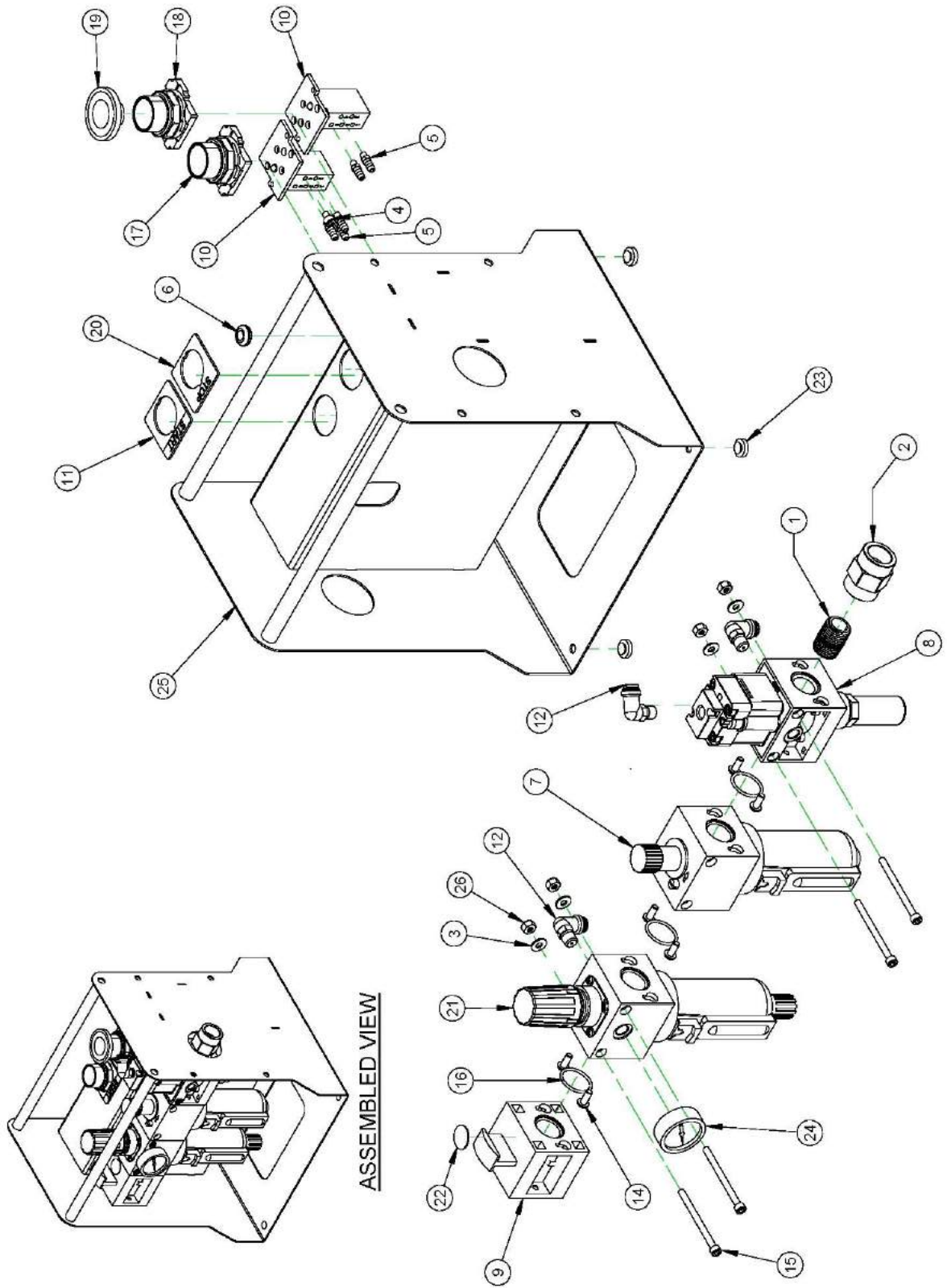
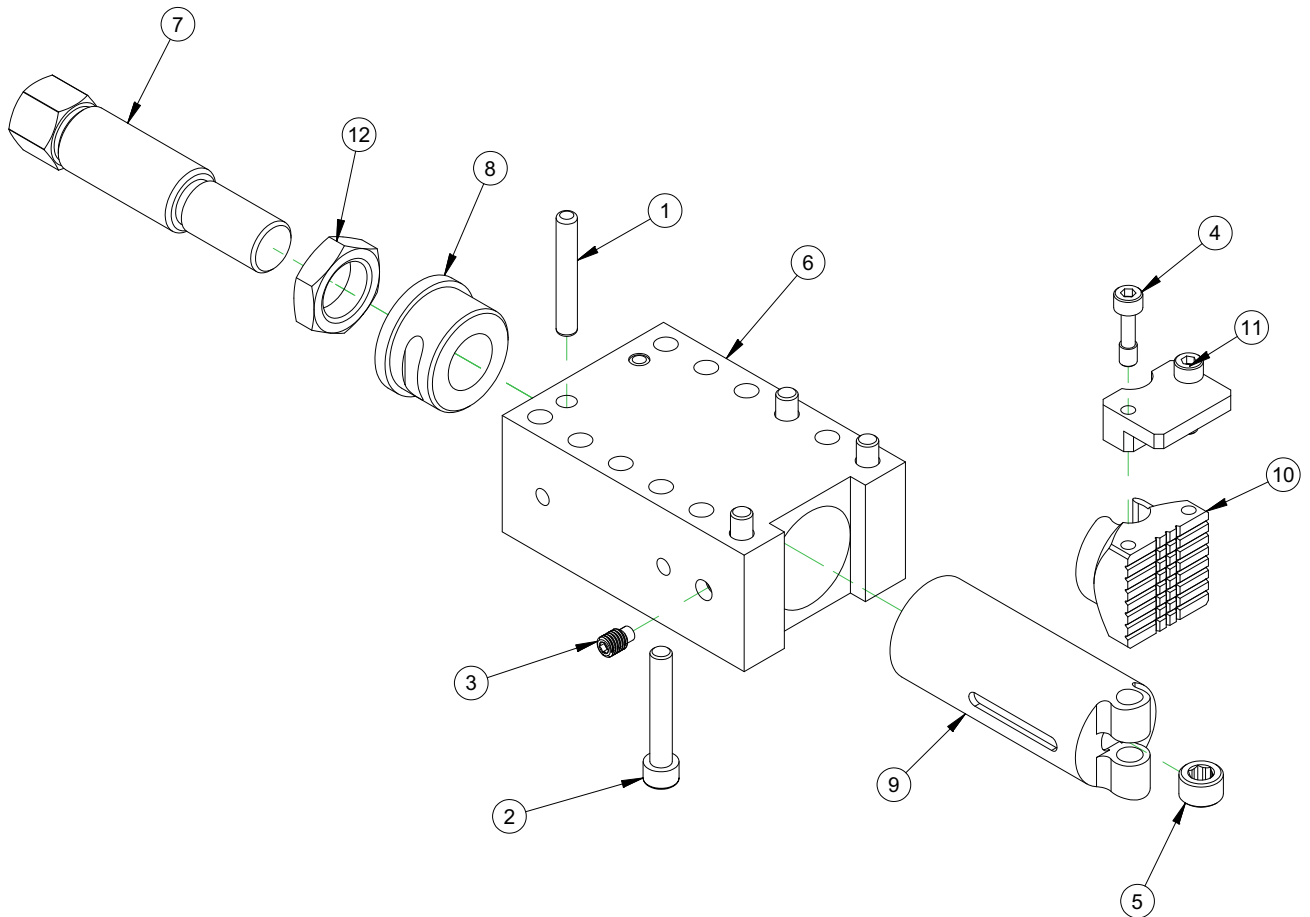

PARTS LIST			
ITEM	QTY	P/N:	DESCRIPTION
1	2	14297	PIN DOWEL 3/8 DIA X 2-1/2
2	4	45754	SCREW M10 x 1.5 x 60mm SHCS
3	1	48998	SCREW M10 X 1.5 X 16mm SSSHDP
4	2	74632	SCREW M8 X 1.25 X 30 OAL X 10 THD L STAINLESS
5	1	80430	SCREW MODIFIED M20 X 1.5 X 12.7MM HOLLOW LOCK
6	1	86881	HOUSING JACKING FOOT
7	1	86882	SCREW JACKING FOOT
8	1	86883	BUSHING THD 1-1/4-7
9	1	86884	RAM JACKING LEVELING
10	1	86885	JAW JACKING LEVELING
11	1	86886	SETUP FINGER
12	1	86908	NUT 1-1/4-7 JAMN 1/2 THICK

FIGURA A-8. MONTAJE DE NIVELACIÓN DE LAS PATAS DE ELEVACIÓN (P/N 86880)



FIGURA A-9. MONTAJE DEL EJE RADIAL (P/N 86890)

PARTS LIST			
ITEM	QTY	P/N:	DESCRIPTION
1	4	10436	WASHER THRUST .500 ID X .937 OD X .060
2	2	10437	BRG THRUST .500 ID X .937 OD X .0781
3	1	11729	PIN DOWEL 1/4 DIA X 3/4
4	3	20398	PIN DOWEL 1/2 DIA X 1
5	20	22572	SCREW M4 X 0.7 X 25mm SHCS
6	2	33777	RING SNAP 1-3/16 ID (30MM)
7	10	35014	SCREW M6 X 1.0 X 16mm SHCS
8	2	35505	SCREW M6 X 1.0 X 30 SHCS
9	1	36087	SCREW M8 X 1.25 X 6MM SSSFP
10	18	38061	SCREW M4 X 0.7 X 20 SHCS
11	2	43489	BALL NYLON 1/8 DIA
12	2	53365	SCREW M4 X 0.7 X 4 mm SSSFP
13	1	57214	BRG RETAINING NUT AXIAL FEED LEADSCREW
14	2	57320	RING O 1/16 X 13/16 ID X 15/16 OD
15	8	61225	SCREW M8 X 1.25 X 40MM SHCS
16	1	62321	HOLDER FELT WIPER MILLING HEAD
17	6	62376	WASHER SPRING BELLEVILLE 1/8 ID X 1/4 OD X .013 THK
18	4	62379	SEAL FELT 16MM BALL SCREW 1.015 OD MILLING HEAD
19	1	62423	MOUNT BALL NUT MILLING HEAD
20	2	62903	WASHER SHIM .75 ID 1.125 OD .062 THICK STEEL
21	2	62909	SCREW 6MM DIA X 12MM X M5 X 0.8 SHLDCS
22	1	62960	BALL SCREW NUT 20MM X 5MM LEAD LEFT HAND 33 MM OD EICHENBERGER ROUND
23	18	68500	CAP RAIL 15MM METAL THK SHS
24	1	72636	ZIMMER BRAKE 15MM RAIL
25	1	72637	ZIMMER ADAPTER 15MM RAIL
26	2	72753	SCREW M8 X 1.25 X 50MM SHCS
27	1	79793	CLAMP COLLAR
28	1	79826	PLATE DOVE CIRCULAR
29	AR	80419	(NOT SHOWN) SHIM 1.8 ID X 3.2 OD .001 THICK
30	AR	80420	(NOT SHOWN) SHIM 1.8 ID X 3.2 OD .002 THICK
31	AR	80421	(NOT SHOWN) SHIM 1.8 ID X 3.2 OD .005 THICK
32	2	82226	COLLAR 8MM ID X 12MM OD X 25MM
33	2	86891	SLIDE RAIL THK SHS15 520MM LG PRELOADED METAL SCRAPERS 2 SHORT BLOCKS
34	1	86892	PLATE RADIAL SADDLE
35	1	86895	BALL SCREW 20MM DIA SF RADIAL AXIS
36	1	86896	PLATE RADIAL AXIS BASE
37	1	86898	BEARING BLOCK BALLSCREW
38	1	87033	PAD POLYURETHANE 1/4 DIA X .08 THICK

FIGURA A-10. LISTA DE PIEZAS DE MONTAJE DEL EJE RADIAL (P/N 86890)

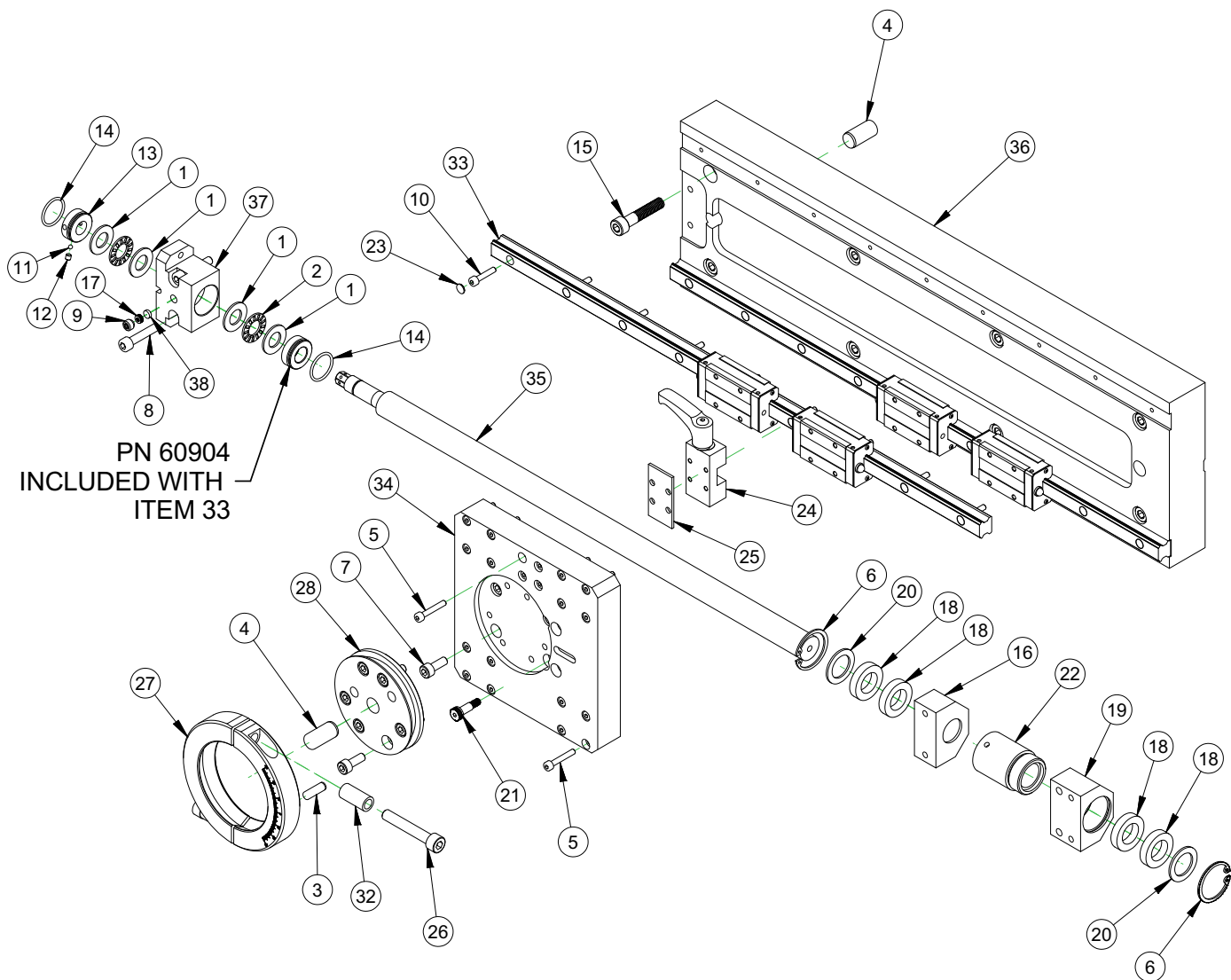
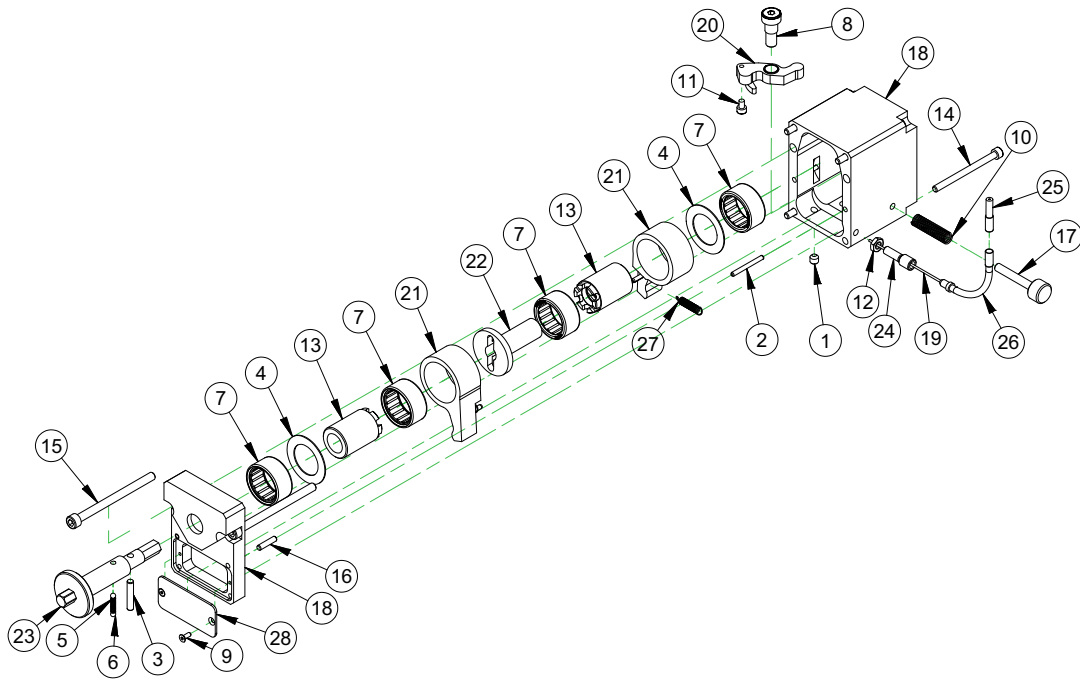

PARTS LIST

ITEM	QTY	P/N:	DESCRIPTION
1	1	10464	SCREW 1/4-20 X 1/4 SSSCP
2	2	11884	PIN DOWEL 1/8 DIA X 1-1/4
3	1	14284	PIN DOWEL 3/16 DIA X 1
4	2	15079	WASHER THRUST 1.000 ID X 1.562 OD X .030
5	1	19561	SPRING COMP .148 OD X .023 WIRE X .50 LONG STAINLESS
6	2	19562	BALL STEEL 5/32 DIA
7	4	25957	BRG ROLLER CLUTCH 1 X 1.312 X .625
8	1	29286	SCREW 3/8 X 3/8 X 5/16-18 SHLDCS
9	2	35876	SCREW M3 X .5 X 8MM FHSCS
10	1	36148	SPRING COMP .36 OD X .032 WIRE X 1.25 LONG
11	1	36152	SCREW M4 X 0.7 X 6mm SHCS
12	1	43019	NUT M6 X 1.0 JAMN ZINC PLATED
13	2	44721	DRIVE BUSHING
14	4	56357	SCREW 10-24 X 2.5 SHCS
15	2	59057	SCREW M6 X 1.0 X 80 mm SHCS CL12.9 ZINC COATED
16	2	60165	PIN DOWEL 5/32 DIA X 11/16
17	1	76599	SCREW M6 X 1.0 X 40MM KNURLED HEAD
18	1	86899	HOUSING FEEDBOX PULL CABLE
19	1	86905	CABLE BRAKE PULL 1.5MM
20	1	86909	PIVOT LINK PULL CABLE FEED
21	2	86973	CLUTCH ARM PULL CABLE FEED
22	1	86978	COUPLING FLANGED 3/8 INTERNAL HEX
23	1	86979	SHAFT PULL CABLE FEED BOX
24	1	87038	BOLT ADJUSTING M6 5MM BRAKE CABLE
25	A/R	87181	HOUSING 5MM DIA BRAKE CABLE
26	1	87198	BEND 90 DEG BRAKE CABLE
27	2	87528	SPRING EXT .18 OD X .023 WIRE X 1-1/4
28	1	87535	COVER FEEDBOX PULL CABLE

FIGURA A-11. MONTAJE DE LA CAJA DE ALIMENTACIÓN DEL CABLE DE TRACCIÓN (P/N 86900)

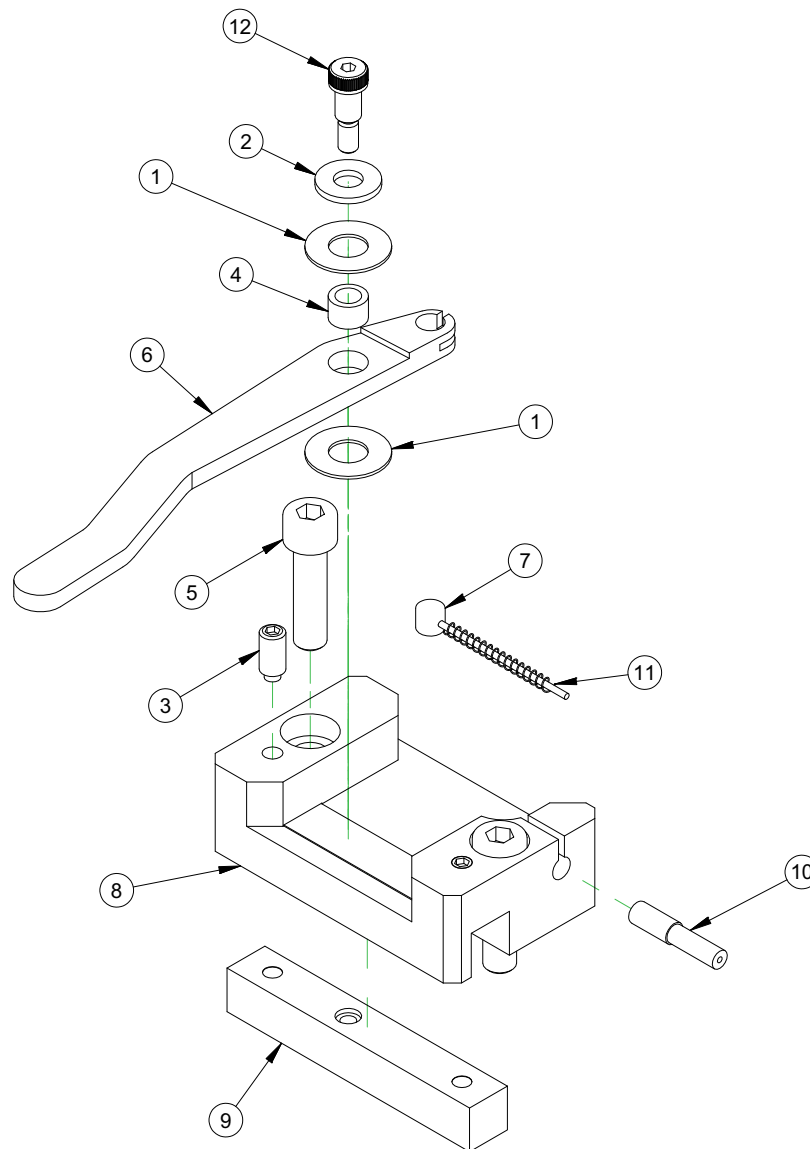

PARTS LIST			
ITEM	QTY	P/N:	DESCRIPTION
1	2	10058	WASHER THRUST .375 ID X .812 OD X .032
2	1	10702	WASHER 1/4 FLTW SAE
3	2	10848	PLUNGER DETENT SPRING STUBBY 1/4-20 X .531
4	1	15259	BUSHING OILITE 1/4 ID X 3/8 OD X 1/4
5	2	45530	SCREW M8 X 1.25 X 30mm SHCS
6	1	86904	TRIP ARM CABLE FEED
7	1	86905	CABLE BRAKE PULL 1.5MM X 1700MM
8	1	86906	BLOCK FEED TRIP ACTUATOR
9	1	86907	KEY PIVOT PULL CABLE FEED
10	A/R	87181	HOUSING 5MM DIA BRAKE CABLE
11	1	87529	SPRING COMP .136 OD X .010 WIRE X 1.34 LONG
12	1	87532	SCREW 1/4 DIA X 3/8 X 10-32 SHLDCS

FIGURA A-12. ACTUADOR DE AVANCE EN EL MONTAJE DE LA CAJA DE ALIMENTACIÓN DEL CABLE DE TRACCIÓN (P/N 86900)

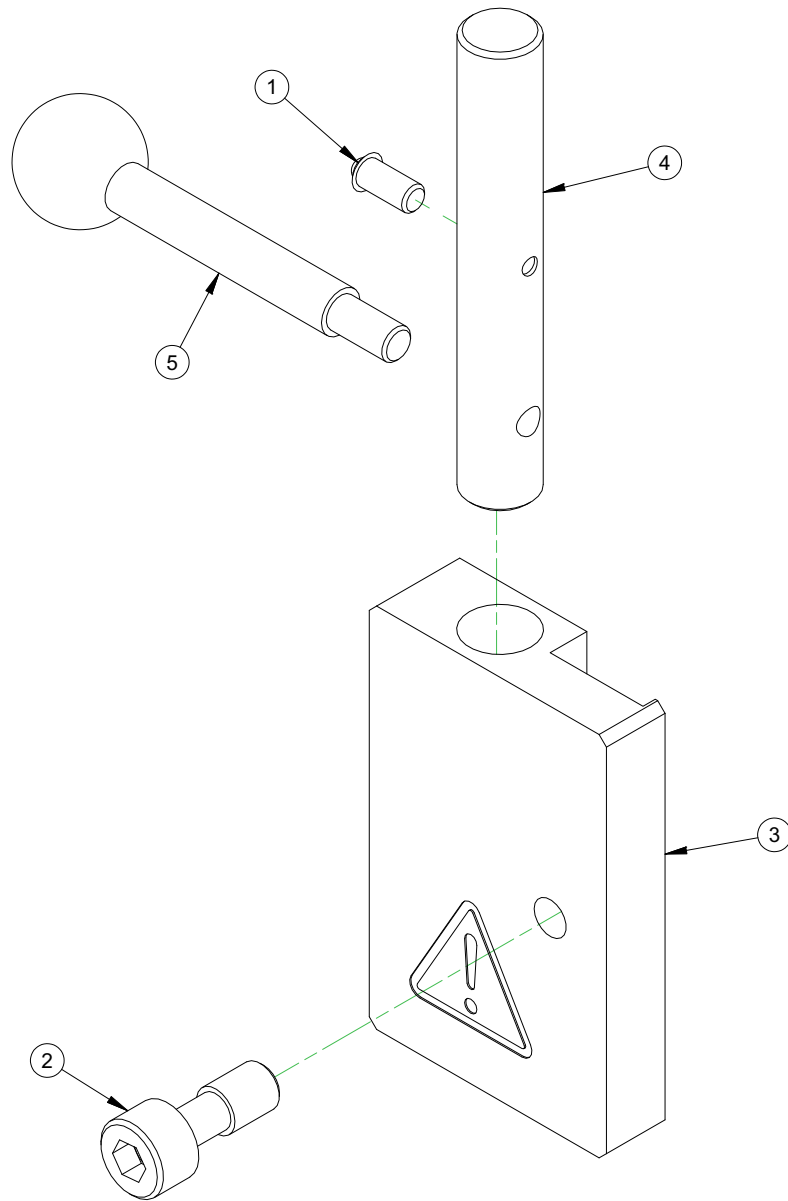

PARTS LIST			
ITEM	QTY	P/N:	DESCRIPTION
1	1	26828	PLUNGER BALL PUSHFIT
2	1	84563	SCREW M8 X 1.25 X 20MM SHCS CAPTIVE 10 THD STAINLESS
3	1	86902	BLOCK FEED TRIP
4	1	86903	ROD FEED TRIP
5	1	87023	LEVER M6 X 1.0 X 63MM ROUND RED HANDLE

FIGURA A-13. MONTAJE DEL ACTIVADOR DE AVANCE (P/N 86910)

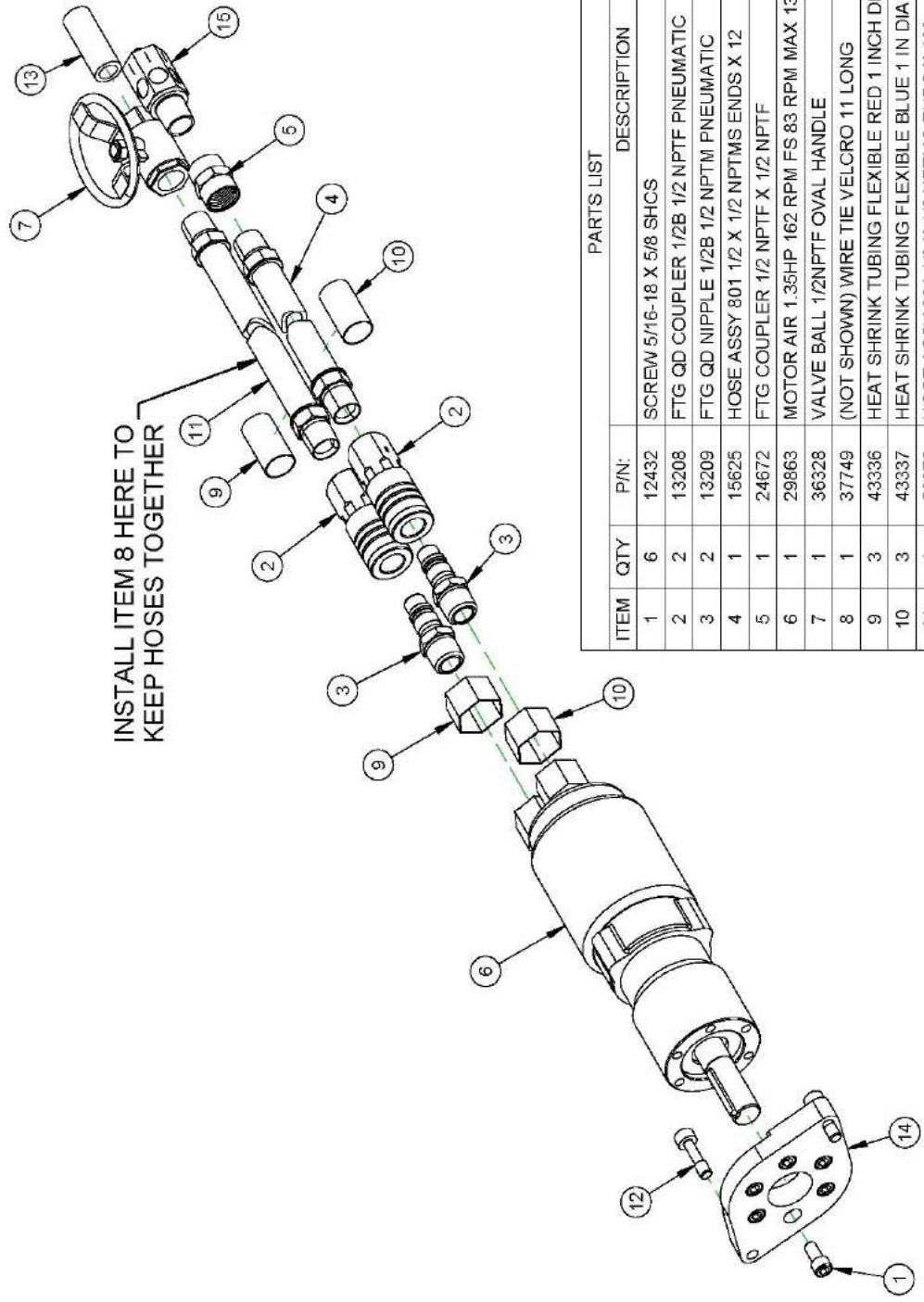

ITEM		QTY	P/N:	DESCRIPTION
1	6	12432	SCREW 5/16-18 X 5/8 SHCS	
2	2	13208	FTG QD COUPLER 1/2B 1/2 NPTF PNEUMATIC	
3	2	13209	FTG QD NIPPLE 1/2B 1/2 NPTM PNEUMATIC	
4	1	15625	HOSE ASSY 801 1/2 X 1/2 NPTMS ENDS X 12	
5	1	24672	FTG COUPLER 1/2 NPTF X 1/2 NPTF	
6	1	29863	MOTOR AIR 1.35HP 162 RPM FS 83 RPM MAX 134TQ REVERSE ROTATION	
7	1	36328	VALVE BALL 1/2NPTF OVAL HANDLE	
8	1	37749	(NOT SHOWN) WIRE TIE VELCRO 11 LONG	
9	3	43336	HEAT SHRINK TUBING FLEXIBLE RED 1 INCH DIA	
10	3	43337	HEAT SHRINK TUBING FLEXIBLE BLUE 1 IN DIA	
11	1	59376	HOSE ASSY 801 1/2 X 1/2 NPTMS ENDS X 180	
12	2	74632	SCREW M8 X 1.25 X 30 OAL X 10 THD L STAINLESS	
13	1	76030	FTG NIPPLE 1/2 NPTM X 2 INCH BRASS	
14	1	86893	PLATE AIR MOTOR MOUNT	
15	1	87263	FTG MUFFLER EXHAUST FLOW CONTROL 1/2 NPTM	

FIGURA A-14. MONTAJE DEL MOTOR DE ACCIONAMIENTO (P/N 86989)

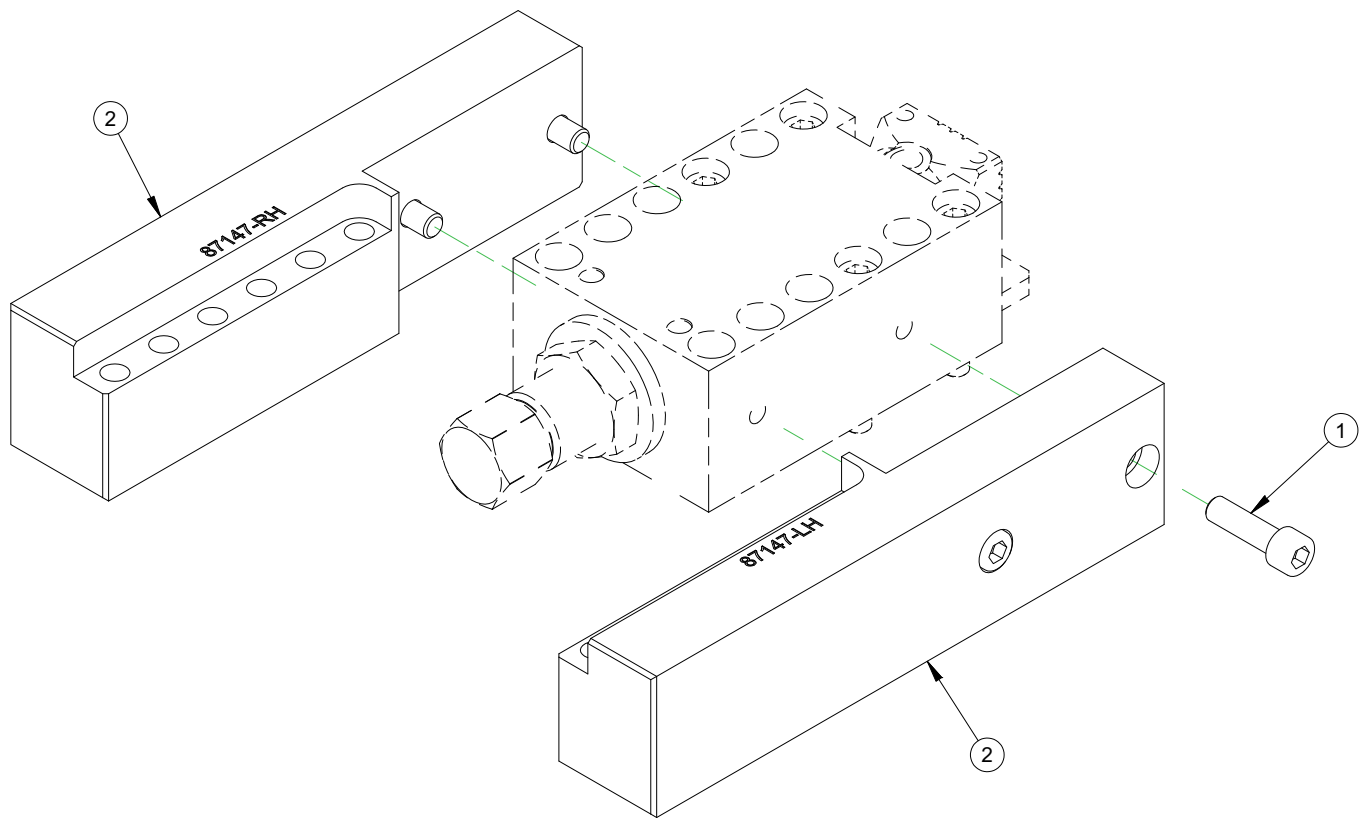

PARTS LIST			
ITEM	QTY	P/N:	DESCRIPTION
1	4	36079	SCREW M10 X 1.5 X 35mm SHCS
2	1	87147	BAR SF MOUNTING FOOT EXTENSION SET

FIGURA A-15. MONTAJE DE LA PATA DE PROLONGACIÓN (P/N 87164)

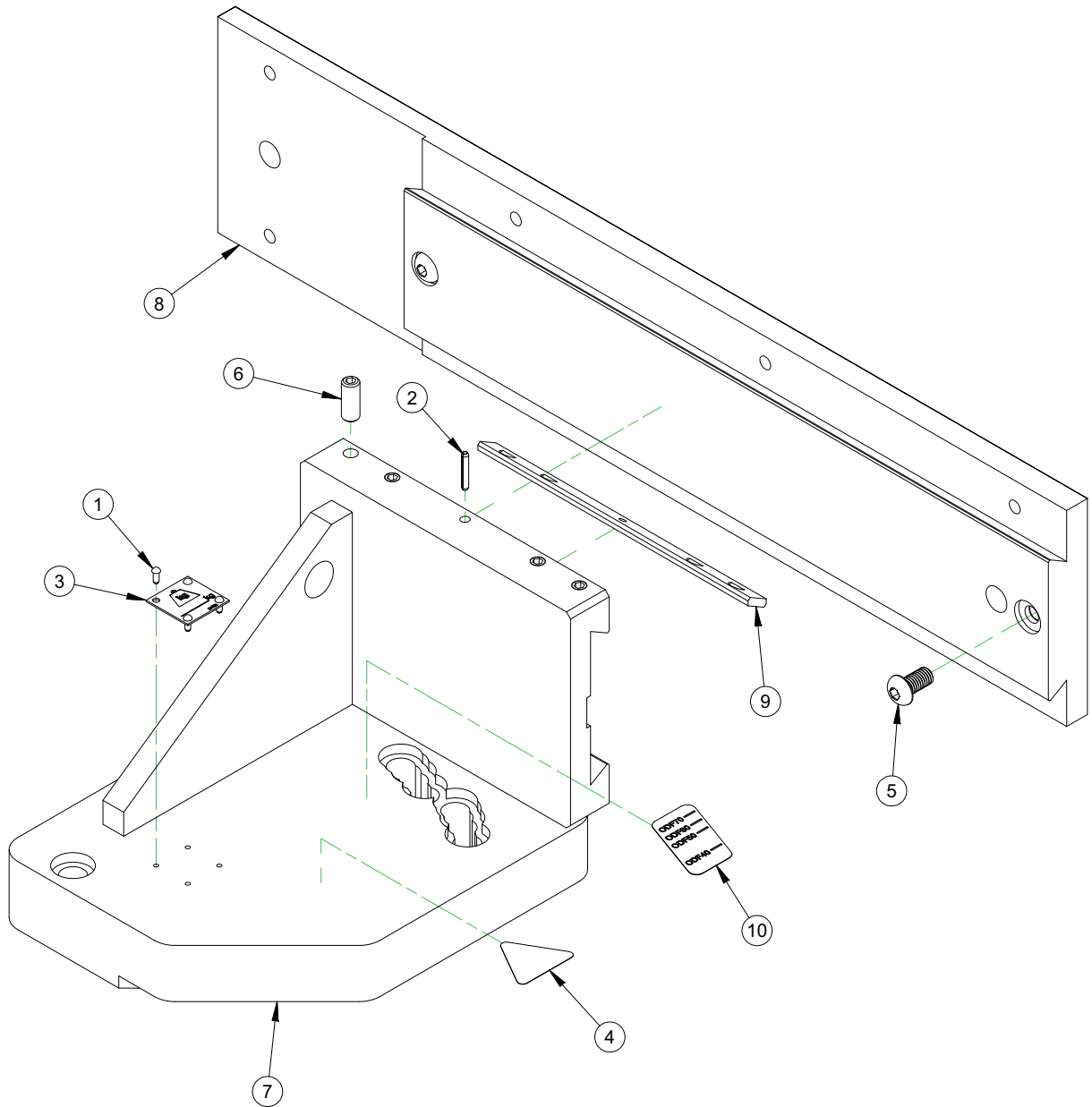

PARTS LIST			
ITEM	QTY	P/N:	DESCRIPTION
1	4	10588	SCREW DRIVE #2 x 1/4 HOLE SIZE .089
2	1	10847	PIN ROLL 1/8 DIA X 3/4
3	1	29152	PLATE MASS CE
4	1	59042	LABEL WARNING - HAND CRUSH/MOVING PARTS
5	2	59827	SCREW M8 X 1.25 X 16MM BHSCS
6	4	83708	SCREW M8 X 1.25 X 20 SSSFP
7	1	87308	WELDMENT BACKFACING ANGLE MOUNT
8	1	87309	PLATE BACKFACING MOUNT
9	1	87416	GIB .435 X .156 X 6.5 0-1 4 SS W/ DOWEL
10	1	87425	LABEL ODF BACKFACING LOCATING

FIGURA A-16. MONTAJE DEL ACCESORIO DE REFRENTADO POSTERIOR (P/N 87310)

TABLA A-1. KIT DE HERRAMIENTAS P/N 78530

Número de pieza	Descripción	Cantidad
14818	CARRACA DE 1/2	1
31158	LLAVE DE VASO HEXAGONAL 5/8 X 1/2 (KB)	1
35516	MARTILLO DE PLÁSTICO 1-3/4 CABEZAL (KB)	1
35821	LLAVE HEXAGONAL 6MM X 6 EMPUÑADURA EN T	1
38678	JUEGO DE LLAVES HEXAGONALES 1.5 - 10MM ACODADAS BONDHUS (KB)	1
39694	PAR DE LLAVE FT-15	1
40806	LLAVE HEXAGONAL 5/16 X 6 EMPUÑADURA EN T	1
41471	ARGOLLA DE ELEVACIÓN 3/8-16 X .56 1.3 ID 2.18 OD 3.79 OAL 1000 LBS OSCILANTE	2
46250	LLAVE DE VASO HEXAGONAL 10MM X 1/2	1
46251	LLAVE DE VASO HEXAGONAL 8MM X 1/2	1
48373	LLAVE MIXTA 1-5/8 12PT	1
55924	LLAVE 3/8 HEXAGONAL (KB)	1
58354	EXTENSIÓN DE LLAVE 1/2 ACCIONAMIENTO X 5	1
86612	LLAVE DE VASO 1-1/4 X 1/2 ACCIONAMIENTO 12 PROFUNDIDAD PUNTO	1
86988	LLAVE DE VASO 7/8 CON EMPUÑADURA	1
87266	INSERTO DE CARBURO 55 DEG DIAMOND IC8250	5
87267	CINCEL 55 DEG DIAMOND 3/4 VÁSTAGO LH	1
87268	CINCEL 55 DEG DIAMOND 3/4 VÁSTAGO NEUTRAL	1

APÉNDICE B SDS

Lista SDS

LPS 1.....	55	Moly Grade antiadherente.....	89
LPS 2.....	64	Nook E-100.....	93
LPS multiusos antiadherente.....	73	Nook PAG-1.....	100
Aceite Mobil Vactra Oil Heavy Medium.....	79	Unax AW 32.....	108

Esta página ha sido intencionalmente dejada en blanco



SAFETY DATA SHEET

1. Identification

Product identifier	LPS® 1 (Aerosol)
Other means of identification	
Part Number	00116
Recommended use	An industrial lubricant designed to displace moisture from mechanical and electrical equipment, provide light-duty lubrication and short-term rust prevention.
Recommended restrictions	None known.
Manufacturer/Importer/Supplier/Distributor information	
Manufacturer	
Manufacturer	
Company name	LPS Laboratories, a division of Illinois Tool Works, Inc.
Address	4647 Hugh Howell Rd. Tucker, GA 30084 (U.S.A.)
Country	(U.S.A.)
In Case of Emergency	Tel: +1 770-243-8800 1-800-424-9300 (inside U.S.) +001 703-527-3887 (outside U.S.)
Website	www.lpslabs.com
E-mail	sds@lpslabs.com

2. Hazard(s) identification

Physical hazards	Flammable aerosols	Category 1
	Gases under pressure	Compressed gas
Health hazards	Skin corrosion/irritation	Category 2
	Sensitization, skin	Category 1B
	Specific target organ toxicity, single exposure	Category 3 narcotic effects
Environmental hazards	Not classified.	
OSHA defined hazards	Not classified.	
Label elements		



Signal word	Danger
Hazard statement	Extremely flammable aerosol. Contains gas under pressure; may explode if heated. Causes skin irritation. May cause an allergic skin reaction. May cause drowsiness or dizziness.
Precautionary statement	
Prevention	Keep away from heat/sparks/open flames/hot surfaces. - No smoking. Do not spray on an open flame or other ignition source. Pressurized container: Do not pierce or burn, even after use. Avoid breathing gas. Wash thoroughly after handling. Use only outdoors or in a well-ventilated area. Contaminated work clothing must not be allowed out of the workplace. Wear protective gloves.
Response	If on skin: Wash with plenty of water. Take off contaminated clothing and wash before reuse. Specific treatment (see this label). If skin irritation or rash occurs: Get medical advice/attention. If inhaled: Remove person to fresh air and keep comfortable for breathing. Call a poison center/doctor if you feel unwell.
Storage	Store in a well-ventilated place. Keep container tightly closed. Store locked up. Protect from sunlight. Do not expose to temperatures exceeding 50°C/122°F.
Disposal	Dispose of contents/container in accordance with local/regional/national/international regulations.
Hazard(s) not otherwise classified (HNOC)	None known.
Supplemental information	None.

Material name: LPS® 1 (Aerosol)
802 Version #: 01 Issue date: 10-01-2014

SDS US
1 / 9

3. Composition/information on ingredients

Mixtures

Chemical name	Common name and synonyms	CAS number	%
Distillates Petroleum, Hydrotreated Light		64742-47-8	70 - 80
Distillates Petroleum Hydrotreated Med		64742-46-7	10 - 20
Carbon Dioxide		124-38-9	1 - 5
Sorbitan trioleate		26266-58-0	1 - 3
Calcium Sulfonate		61789-86-4	0.1 - 1

4. First-aid measures

Inhalation	Remove victim to fresh air and keep at rest in a position comfortable for breathing. Call a POISON CENTER or doctor/physician if you feel unwell.
Skin contact	Remove contaminated clothing immediately and wash skin with soap and water. In case of eczema or other skin disorders: Seek medical attention and take along these instructions. Wash contaminated clothing before reuse.
Eye contact	Immediately flush eyes with plenty of water for at least 15 minutes. Remove contact lenses, if present and easy to do. Continue rinsing. Get medical attention if irritation develops and persists.
Ingestion	In the unlikely event of swallowing contact a physician or poison control center. Rinse mouth. Do not induce vomiting without advice from poison control center. If vomiting occurs, keep head low so that stomach content doesn't get into the lungs.
Most important symptoms/effects, acute and delayed	May cause drowsiness and dizziness. Headache. Nausea, vomiting. Rash. Skin irritation. May cause redness and pain. May cause an allergic skin reaction. Dermatitis.
Indication of immediate medical attention and special treatment needed	Provide general supportive measures and treat symptomatically. Keep victim under observation. Symptoms may be delayed.
General information	Ensure that medical personnel are aware of the material(s) involved, and take precautions to protect themselves. Wash contaminated clothing before reuse.

5. Fire-fighting measures

Suitable extinguishing media	Alcohol resistant foam. Water spray. Water fog. Dry chemical powder. Dry chemicals. Carbon dioxide (CO2).
Unsuitable extinguishing media	Do not use water jet as an extinguisher, as this will spread the fire.
Specific hazards arising from the chemical	Contents under pressure. Pressurized container may explode when exposed to heat or flame. During fire, gases hazardous to health may be formed.
Special protective equipment and precautions for firefighters	Firefighters must use standard protective equipment including flame retardant coat, helmet with face shield, gloves, rubber boots, and in enclosed spaces, SCBA.
Fire fighting equipment/instructions	In case of fire: Stop leak if safe to do so. Move containers from fire area if you can do so without risk. Cool containers exposed to heat with water spray and remove container, if no risk is involved. Containers should be cooled with water to prevent vapor pressure build up. For massive fire in cargo area, use unmanned hose holder or monitor nozzles, if possible. If not, withdraw and let fire burn out.
Specific methods	Use standard firefighting procedures and consider the hazards of other involved materials. Move containers from fire area if you can do so without risk. Cool containers exposed to flames with water until well after the fire is out. In the event of fire and/or explosion do not breathe fumes.
General fire hazards	Extremely flammable aerosol. Contents under pressure. Pressurized container may explode when exposed to heat or flame.

6. Accidental release measures

Personal precautions, protective equipment and emergency procedures	Keep unnecessary personnel away. Keep people away from and upwind of spill/leak. Keep out of low areas. Many gases are heavier than air and will spread along ground and collect in low or confined areas (sewers, basements, tanks). Wear appropriate protective equipment and clothing during clean-up. Avoid breathing gas. Do not touch damaged containers or spilled material unless wearing appropriate protective clothing. Ventilate closed spaces before entering them. Local authorities should be advised if significant spillages cannot be contained. Use personal protection recommended in Section 8 of the SDS.
--	---

Methods and materials for containment and cleaning up

Refer to attached safety data sheets and/or instructions for use. Eliminate all ignition sources (no smoking, flares, sparks, or flames in immediate area). Keep combustibles (wood, paper, oil, etc.) away from spilled material. Stop leak if you can do so without risk. Move the cylinder to a safe and open area if the leak is irreparable. Use water spray to reduce vapors or divert vapor cloud drift. Isolate area until gas has dispersed. Dike far ahead of spill for later disposal. Scoop up used absorbent into drums or other appropriate container. Prevent entry into waterways, sewer, basements or confined areas. Following product recovery, flush area with water. For waste disposal, see section 13 of the SDS.

Environmental precautions

Avoid discharge into drains, water courses or onto the ground.

7. Handling and storage

Precautions for safe handling

Pressurized container: Do not pierce or burn, even after use. Do not use if spray button is missing or defective. Do not spray on a naked flame or any other incandescent material. Do not smoke while using or until sprayed surface is thoroughly dry. Do not cut, weld, solder, drill, grind, or expose containers to heat, flame, sparks, or other sources of ignition. Do not re-use empty containers. Avoid breathing gas. Avoid contact with eyes, skin, and clothing. Avoid prolonged exposure. Use only in well-ventilated areas. Wear appropriate personal protective equipment. Observe good industrial hygiene practices.

Conditions for safe storage, including any incompatibilities

Level 1 Aerosol.

Store locked up. Pressurized container. Protect from sunlight and do not expose to temperatures exceeding 50°C/122 °F. Do not puncture, incinerate or crush. Do not handle or store near an open flame, heat or other sources of ignition. Store in original tightly closed container. Store in a well-ventilated place. Keep out of the reach of children. Store away from incompatible materials (see Section 10 of the SDS).

8. Exposure controls/personal protection

Occupational exposure limits

U.S. - OSHA Components

Components	Type	Value	Form
Distillates Petroleum, Hydrotreated Light (CAS 64742-47-8)	PEL	5 mg/m3	Oil mist

US. OSHA Table Z-1 Limits for Air Contaminants (29 CFR 1910.1000) Components

Components	Type	Value
Carbon Dioxide (CAS 124-38-9)	PEL	9000 mg/m3 5000 ppm

ACGIH Components

Components	Type	Value	Form
Distillates Petroleum, Hydrotreated Light (CAS 64742-47-8)	TWA	5 mg/m3	Oil mist

US. ACGIH Threshold Limit Values Components

Components	Type	Value
Carbon Dioxide (CAS 124-38-9)	STEL	30000 ppm
	TWA	5000 ppm

US. NIOSH: Pocket Guide to Chemical Hazards Components

Components	Type	Value
Carbon Dioxide (CAS 124-38-9)	STEL	54000 mg/m3
	TWA	30000 ppm 9000 mg/m3 5000 ppm

Biological limit values

No biological exposure limits noted for the ingredient(s).

Appropriate engineering controls

Good general ventilation (typically 10 air changes per hour) should be used. Ventilation rates should be matched to conditions. If applicable, use process enclosures, local exhaust ventilation, or other engineering controls to maintain airborne levels below recommended exposure limits. If exposure limits have not been established, maintain airborne levels to an acceptable level.

Individual protection measures, such as personal protective equipment

Eye/face protection	Wear safety glasses with side shields (or goggles).
Skin protection	
Hand protection	Chemical resistant gloves are recommended.
Other	Avoid contact with the skin. Wear appropriate chemical resistant clothing.
Respiratory protection	When workers are facing concentrations above the exposure limit they must use appropriate certified respirators.
Thermal hazards	Not applicable.
General hygiene considerations	Always observe good personal hygiene measures, such as washing after handling the material and before eating, drinking, and/or smoking. Routinely wash work clothing and protective equipment to remove contaminants.

9. Physical and chemical properties

Appearance	Liquid.
Physical state	Gas.
Form	Aerosol.
Color	Amber.
Odor	Characteristic.
Odor threshold	Not available.
pH	Not applicable
Melting point/freezing point	< -58 °F (< -50 °C)
Initial boiling point and boiling range	415.4 °F (213 °C)
Flash point	174.2 °F (79.0 °C) Tag Closed Cup (dispensed liquid)
Evaporation rate	< 0.1 (BuAc = 1)
Flammability (solid, gas)	Flammable gas.
Upper/lower flammability or explosive limits	
Flammability limit - lower (%)	0.6 %
Flammability limit - upper (%)	7 %
Explosive limit - lower (%)	Not available.
Explosive limit - upper (%)	Not available.
Vapor pressure	< 0.05 mm Hg @ 20°C
Vapor density	> 1 (air = 1)
Relative density	0.79 - 0.81 @ 20°C
Solubility(ies)	
Solubility (water)	Not soluble
Partition coefficient (n-octanol/water)	< 1
Auto-ignition temperature	> 442.4 °F (> 228 °C)
Decomposition temperature	Not established
Viscosity	< 3.8 cSt @ 25°C
Other information	
Heat of combustion	Not established
Percent volatile	95 - 96 %
VOC (Weight %)	0.4 % per US State & Federal Consumer Product Regulations

10. Stability and reactivity

Reactivity	The product is stable and non-reactive under normal conditions of use, storage and transport.
Chemical stability	Material is stable under normal conditions.

Possibility of hazardous reactions	Hazardous polymerization does not occur.
Conditions to avoid	Avoid heat, sparks, open flames and other ignition sources. Avoid temperatures exceeding the flash point. Contact with incompatible materials.
Incompatible materials	Oxidizing agents.
Hazardous decomposition products	Carbon oxides.

11. Toxicological information

Information on likely routes of exposure

Inhalation	Vapors have a narcotic effect and may cause headache, fatigue, dizziness and nausea.
Skin contact	Causes skin irritation. May cause an allergic skin reaction.
Eye contact	Direct contact with eyes may cause temporary irritation.
Ingestion	May be fatal if swallowed and enters airways.

Symptoms related to the physical, chemical and toxicological characteristics
Symptoms may include stinging, tearing, redness, swelling, and blurred vision. Skin irritation. Exposure may cause temporary irritation, redness, or discomfort. Defatting of the skin. Rash. Vapors have a narcotic effect and may cause headache, fatigue, dizziness and nausea. Decrease in motor functions. Behavioral changes.

Information on toxicological effects

Acute toxicity Narcotic effects. May cause an allergic skin reaction.

Components	Species	Test Results
Calcium Sulfonate (CAS 61789-86-4)		
Acute		
<i>Dermal</i>		
LD50	Rabbit	> 2000 mg/kg, 24 Hours
	Rat	> 2000 mg/kg, 24 Hours
<i>Inhalation</i>		
LC50	Rat	> 1.9 mg/l, 4 Hours
<i>Oral</i>		
LD50	Rat	10000 - 20000 mg/kg
Distillates Petroleum Hydrotreated Med (CAS 64742-46-7)		
Acute		
<i>Dermal</i>		
LD50	Rabbit	> 2000 mg/kg, 24 Hours
<i>Inhalation</i>		
LC50	Rat	7640 mg/m ³ , 4 Hours 1.72 mg/l, 4 Hours
Distillates Petroleum, Hydrotreated Light (CAS 64742-47-8)		
Acute		
<i>Dermal</i>		
LD50	Rabbit	> 2000 mg/kg > 2000 mg/kg, 24 Hours
<i>Inhalation</i>		
LC50	Cat	> 6.4 mg/l, 6 Hours
	Rat	> 7.5 mg/l, 6 Hours > 4.3 mg/l, 4 Hours > 0.1 mg/l, 8 Hours
<i>Oral</i>		
LD50	Rat	> 5000 mg/kg
Skin corrosion/irritation	Causes skin irritation.	
Serious eye damage/eye irritation	Direct contact with eyes may cause temporary irritation.	

Respiratory or skin sensitization

Respiratory sensitization	Not a respiratory sensitizer.
Skin sensitization	May cause an allergic skin reaction.
Germ cell mutagenicity	No data available to indicate product or any components present at greater than 0.1% are mutagenic or genotoxic.
Carcinogenicity	This product is not considered to be a carcinogen by IARC, ACGIH, NTP, or OSHA.

OSHA Specifically Regulated Substances (29 CFR 1910.1001-1050)

Not listed.

Reproductive toxicity	This product is not expected to cause reproductive or developmental effects.
Specific target organ toxicity - single exposure	Narcotic effects.
Specific target organ toxicity - repeated exposure	Based on available data, the classification criteria are not met.
Aspiration hazard	Not likely, due to the form of the product.
Chronic effects	Prolonged inhalation may be harmful.

12. Ecological information

Ecotoxicity Harmful to aquatic life with long lasting effects.

Components	Species	Test Results
Distillates Petroleum, Hydrotreated Light (CAS 64742-47-8)		
Aquatic		
Fish	LC50 Rainbow trout, donaldson trout (Oncorhynchus mykiss)	2.9 mg/l, 96 hours

Persistence and degradability Not inherently biodegradable.

Bioaccumulative potential Not available.

Partition coefficient n-octanol / water (log Kow)

LPS® 1 (Aerosol) < 1

Mobility in soil No data available.

Other adverse effects None known.

13. Disposal considerations

Disposal instructions Consult authorities before disposal. Contents under pressure. Do not puncture, incinerate or crush. Dispose of contents/container in accordance with local/regional/national/international regulations.

Local disposal regulations Dispose in accordance with all applicable regulations.

Hazardous waste code D003: Waste Reactive material

Waste from residues / unused products Dispose of in accordance with local regulations. Empty containers or liners may retain some product residues. This material and its container must be disposed of in a safe manner (see: Disposal instructions).

Contaminated packaging Empty containers should be taken to an approved waste handling site for recycling or disposal. Since emptied containers may retain product residue, follow label warnings even after container is emptied. Do not re-use empty containers.

14. Transport information

DOT

UN number	UN1950
UN proper shipping name	Aerosols, flammable
Transport hazard class(es)	
Class	2.1
Subsidiary risk	-
Label(s)	2.1
Packing group	Not applicable.
Environmental hazards	
Marine pollutant	No
Special precautions for user	Read safety instructions, SDS and emergency procedures before handling.
Special provisions	N82
Packaging exceptions	306

Packaging non bulk None
 Packaging bulk None

IATA

UN number UN1950
 UN proper shipping name Aerosols, flammable
 Transport hazard class(es)
 Class 2.1
 Subsidiary risk -
 Packing group Not applicable.
 Environmental hazards No
 ERG Code 10L
 Special precautions for user Read safety instructions, SDS and emergency procedures before handling.
 Other information
 Passenger and cargo aircraft Allowed.
 Cargo aircraft only Allowed.

IMDG

UN number UN1950
 UN proper shipping name AEROSOLS, Flammable
 Transport hazard class(es)
 Class 2.1
 Subsidiary risk -
 Label(s) 2.1
 Packing group Not applicable.
 Environmental hazards
 Marine pollutant No
 EmS F-D, S-U
 Special precautions for user Read safety instructions, SDS and emergency procedures before handling.

Transport in bulk according to Annex II of MARPOL 73/78 and the IBC Code This substance/mixture is not intended to be transported in bulk.

DOT**IATA; IMDG****15. Regulatory information**

US federal regulations This product is a "Hazardous Chemical" as defined by the OSHA Hazard Communication Standard, 29 CFR 1910.1200.
 All components are on the U.S. EPA TSCA Inventory List.

TSCA Section 12(b) Export Notification (40 CFR 707, Subpt. D)

Not regulated.

CERCLA Hazardous Substance List (40 CFR 302.4)

Not listed.

SARA 304 Emergency release notification

Not regulated.

OSHA Specifically Regulated Substances (29 CFR 1910.1001-1050)

Not listed.

Superfund Amendments and Reauthorization Act of 1986 (SARA)

Hazard categories
 Immediate Hazard - Yes
 Delayed Hazard - No
 Fire Hazard - Yes
 Pressure Hazard - Yes
 Reactivity Hazard - No

SARA 302 Extremely hazardous substance

Not listed.

SARA 311/312 Hazardous chemical Yes

SARA 313 (TRI reporting)

Not regulated.

Other federal regulations**Clean Air Act (CAA) Section 112 Hazardous Air Pollutants (HAPs) List**

Not regulated.

Clean Air Act (CAA) Section 112(r) Accidental Release Prevention (40 CFR 68.130)

Not regulated.

Safe Drinking Water Act (SDWA) Not regulated.

US state regulations**US. California Controlled Substances. CA Department of Justice (California Health and Safety Code Section 11100)**

Not listed.

US. Massachusetts RTK - Substance List

Carbon Dioxide (CAS 124-38-9)

US. New Jersey Worker and Community Right-to-Know Act

Carbon Dioxide (CAS 124-38-9)

US. Pennsylvania Worker and Community Right-to-Know Law

Carbon Dioxide (CAS 124-38-9)

US. Rhode Island RTK

Not regulated.

US. California Proposition 65

California Safe Drinking Water and Toxic Enforcement Act of 1986 (Proposition 65): This material is not known to contain any chemicals currently listed as carcinogens or reproductive toxins.

International Inventories

Country(s) or region	Inventory name	On inventory (yes/no)*
Australia	Australian Inventory of Chemical Substances (AICS)	Yes
Canada	Domestic Substances List (DSL)	Yes
Canada	Non-Domestic Substances List (NDSL)	No
China	Inventory of Existing Chemical Substances in China (IECSC)	No
Europe	European Inventory of Existing Commercial Chemical Substances (EINECS)	Yes
Europe	European List of Notified Chemical Substances (ELINCS)	No
Japan	Inventory of Existing and New Chemical Substances (ENCS)	No
Korea	Existing Chemicals List (ECL)	Yes
New Zealand	New Zealand Inventory	No
Philippines	Philippine Inventory of Chemicals and Chemical Substances (PICCS)	Yes

Country(s) or region	Inventory name	On inventory (yes/no)*
United States & Puerto Rico	Toxic Substances Control Act (TSCA) Inventory	Yes

*A "Yes" indicates that all components of this product comply with the inventory requirements administered by the governing country(s)
A "No" indicates that one or more components of the product are not listed or exempt from listing on the inventory administered by the governing country(s).

16. Other information, including date of preparation or last revision

Issue date	10-01-2014
Version #	01
Disclaimer	LPS Laboratories cannot anticipate all conditions under which this information and its product, or the products of other manufacturers in combination with its product, may be used. It is the user's responsibility to ensure safe conditions for handling, storage and disposal of the product, and to assume liability for loss, injury, damage or expense due to improper use. The information provided in this Safety Data Sheet is correct to the best of our knowledge, information and belief at the date of its publication. The information given is designed only as a guidance for safe handling, use, processing, storage, transportation, disposal and release and is not to be considered a warranty or quality specification. The information relates only to the specific material designated and may not be valid for such material used in combination with any other materials or in any process, unless specified in the text.



SAFETY DATA SHEET

1. Identification

Product identifier	LPS® 2 (Aerosol)
Other means of identification	
Part Number	00216
Recommended use	An industrial lubricant designed to displace moisture from equipment, provide heavy-duty lubrication and rust prevention.
Recommended restrictions	None known.
Manufacturer/Importer/Supplier/Distributor information	
Manufacturer	
Manufacturer	
Company name	LPS Laboratories, a division of Illinois Tool Works, Inc.
Address	4647 Hugh Howell Rd. Tucker, GA 30084 (U.S.A.)
Country	(U.S.A.)
In Case of Emergency	Tel: +1 770-243-8800 1-800-424-9300 (inside U.S.) +001 703-527-3887 (outside U.S.)
Website	www.lpslabs.com
E-mail	sds@lpslabs.com

2. Hazard(s) identification

Physical hazards	Flammable aerosols	Category 1
	Gases under pressure	Compressed gas
Health hazards	Skin corrosion/irritation	Category 2
	Serious eye damage/eye irritation	Category 2A
	Specific target organ toxicity, single exposure	Category 3 narcotic effects
Environmental hazards	Not classified.	
OSHA defined hazards	Not classified.	
Label elements		



Signal word	Danger
Hazard statement	Extremely flammable aerosol. Contains gas under pressure; may explode if heated. Causes skin irritation. Causes serious eye irritation. May cause drowsiness or dizziness.
Precautionary statement	
Prevention	Keep away from heat/sparks/open flames/hot surfaces. - No smoking. Do not spray on an open flame or other ignition source. Pressurized container: Do not pierce or burn, even after use. Avoid breathing gas. Wash thoroughly after handling. Use only outdoors or in a well-ventilated area. Wear protective gloves. Wear eye/face protection.
Response	If on skin: Wash with plenty of water. If inhaled: Remove person to fresh air and keep comfortable for breathing. If in eyes: Rinse cautiously with water for several minutes. Remove contact lenses, if present and easy to do. Continue rinsing. Call a poison center/doctor if you feel unwell. Specific treatment (see this label). If skin irritation occurs: Get medical advice/attention. If eye irritation persists: Get medical advice/attention. Take off contaminated clothing and wash before reuse.
Storage	Store in a well-ventilated place. Keep container tightly closed. Store locked up. Protect from sunlight. Do not expose to temperatures exceeding 50°C/122°F.
Disposal	Dispose of contents/container in accordance with local/regional/national/international regulations.
Hazard(s) not otherwise classified (HNOC)	None known.

Supplemental information None.

3. Composition/information on ingredients

Mixtures

Chemical name	Common name and synonyms	CAS number	%
Distillates Petroleum, Hydrotreated Light		64742-47-8	70 - 80
Petroleum Oil		64742-52-5	10 - 20
Carbon Dioxide		124-38-9	1 - 5

4. First-aid measures

Inhalation	Remove victim to fresh air and keep at rest in a position comfortable for breathing. For breathing difficulties, oxygen may be necessary. Call a physician if symptoms develop or persist.
Skin contact	Wash off with soap and water. Get medical attention if irritation develops and persists.
Eye contact	Immediately flush eyes with plenty of water for at least 15 minutes. Remove contact lenses, if present and easy to do. Continue rinsing. Get medical attention if irritation develops and persists.
Ingestion	Call a physician or poison control center immediately. Only induce vomiting at the instruction of medical personnel. Never give anything by mouth to an unconscious person. If vomiting occurs, keep head low so that stomach content doesn't get into the lungs.
Most important symptoms/effects, acute and delayed	Dermatitis. Rash. Symptoms of overexposure may be headache, dizziness, tiredness, nausea and vomiting. Skin irritation. May cause redness and pain.
Indication of immediate medical attention and special treatment needed	Provide general supportive measures and treat symptomatically.
General information	Ensure that medical personnel are aware of the material(s) involved, and take precautions to protect themselves. Call a POISON CENTER or doctor/physician if you feel unwell.

5. Fire-fighting measures

Suitable extinguishing media	Powder. Alcohol resistant foam. Water. Water spray. Dry chemicals. Carbon dioxide (CO2).
Unsuitable extinguishing media	Do not use water jet as an extinguisher, as this will spread the fire.
Specific hazards arising from the chemical	Contents under pressure. Pressurized container may explode when exposed to heat or flame.
Special protective equipment and precautions for firefighters	Firefighters must use standard protective equipment including flame retardant coat, helmet with face shield, gloves, rubber boots, and in enclosed spaces, SCBA.
Fire fighting equipment/instructions	In case of fire: Stop leak if safe to do so. Move containers from fire area if you can do so without risk. Cool containers exposed to heat with water spray and remove container, if no risk is involved. Containers should be cooled with water to prevent vapor pressure build up. For massive fire in cargo area, use unmanned hose holder or monitor nozzles, if possible. If not, withdraw and let fire burn out.
Specific methods	Use standard firefighting procedures and consider the hazards of other involved materials. Move containers from fire area if you can do so without risk. Cool containers exposed to flames with water until well after the fire is out. In the event of fire and/or explosion do not breathe fumes.
General fire hazards	Extremely flammable aerosol.

6. Accidental release measures

Personal precautions, protective equipment and emergency procedures	Keep unnecessary personnel away. Keep people away from and upwind of spill/leak. Keep out of low areas. Wear appropriate protective equipment and clothing during clean-up. Do not touch damaged containers or spilled material unless wearing appropriate protective clothing. Ventilate closed spaces before entering them. Local authorities should be advised if significant spillages cannot be contained. Use personal protection recommended in Section 8 of the SDS.
Methods and materials for containment and cleaning up	Refer to attached safety data sheets and/or instructions for use. Eliminate all ignition sources (no smoking, flares, sparks, or flames in immediate area). Keep combustibles (wood, paper, oil, etc.) away from spilled material. Stop leak if you can do so without risk. Move the cylinder to a safe and open area if the leak is irreparable. Isolate area until gas has dispersed. Use water spray to reduce vapors or divert vapor cloud drift. Scoop up used absorbent into drums or other appropriate container. Prevent entry into waterways, sewer, basements or confined areas. Following product recovery, flush area with water. For waste disposal, see section 13 of the SDS.
Environmental precautions	Avoid discharge into drains, water courses or onto the ground.

Material name: LPS® 2 (Aerosol)
729 Version #: 01 Issue date: 09-22-2014

SDS US
2 / 9

7. Handling and storage

Precautions for safe handling

Pressurized container: Do not pierce or burn, even after use. Do not use if spray button is missing or defective. Do not spray on a naked flame or any other incandescent material. Do not smoke while using or until sprayed surface is thoroughly dry. Do not cut, weld, solder, drill, grind, or expose containers to heat, flame, sparks, or other sources of ignition. All equipment used when handling the product must be grounded. Do not re-use empty containers. Avoid prolonged or repeated contact with skin. Avoid prolonged exposure. Use only in well-ventilated areas. Wear appropriate personal protective equipment. Wash hands thoroughly after handling. Observe good industrial hygiene practices.

Conditions for safe storage, including any incompatibilities

Level 3 Aerosol.

Store locked up. Pressurized container. Protect from sunlight and do not expose to temperatures exceeding 50°C/122 °F. Do not puncture, incinerate or crush. Do not handle or store near an open flame, heat or other sources of ignition. This material can accumulate static charge which may cause spark and become an ignition source. Prevent electrostatic charge build-up by using common bonding and grounding techniques. Store in original tightly closed container. Store in a well-ventilated place. Store away from incompatible materials (see Section 10 of the SDS). Keep out of the reach of children.

8. Exposure controls/personal protection

Occupational exposure limits

U.S. - OSHA Components

Distillates Petroleum,
Hydrotreated Light (CAS
64742-47-8)

Type

PEL

Value

5 mg/m³

Form

Oil mist

Petroleum Oil (CAS
64742-52-5)

PEL

5 mg/m³

Oil mist

US. OSHA Table Z-1 Limits for Air Contaminants (29 CFR 1910.1000)

Components

Type

Value

Carbon Dioxide (CAS
124-38-9)

PEL

9000 mg/m³

5000 ppm

ACGIH

Components

Type

Value

Form

Distillates Petroleum,
Hydrotreated Light (CAS
64742-47-8)

TWA

5 mg/m³

Oil mist

Petroleum Oil (CAS
64742-52-5)

TWA

5 mg/m³

Oil mist

US. ACGIH Threshold Limit Values

Components

Type

Value

Carbon Dioxide (CAS
124-38-9)

STEL

30000 ppm

TWA

5000 ppm

US. NIOSH: Pocket Guide to Chemical Hazards

Components

Type

Value

Carbon Dioxide (CAS
124-38-9)

STEL

54000 mg/m³

30000 ppm

TWA

9000 mg/m³

5000 ppm

Biological limit values

No biological exposure limits noted for the ingredient(s).

Appropriate engineering controls

Good general ventilation (typically 10 air changes per hour) should be used. Ventilation rates should be matched to conditions. If applicable, use process enclosures, local exhaust ventilation, or other engineering controls to maintain airborne levels below recommended exposure limits. If exposure limits have not been established, maintain airborne levels to an acceptable level. Eye wash facilities and emergency shower must be available when handling this product.

Individual protection measures, such as personal protective equipment

Eye/face protection

Wear safety glasses with side shields (or goggles).

Skin protection	
Hand protection	Chemical resistant gloves are recommended.
Other	Wear suitable protective clothing.
Respiratory protection	In case of insufficient ventilation, wear suitable respiratory equipment.
Thermal hazards	Not applicable.
General hygiene considerations	When using, do not eat, drink or smoke. Always observe good personal hygiene measures, such as washing after handling the material and before eating, drinking, and/or smoking. Routinely wash work clothing and protective equipment to remove contaminants.

9. Physical and chemical properties

Appearance	Liquid.
Physical state	Gas.
Form	Aerosol.
Color	Brown
Odor	Slight petroleum odor, Cherry
Odor threshold	Not established
pH	Not applicable
Melting point/freezing point	< -58 °F (< -50 °C)
Initial boiling point and boiling range	383 °F (195 °C) @ 101 kPa
Flash point	174.2 °F (79.0 °C) Tag Closed Cup (dispensed liquid)
Evaporation rate	< 0.1 BuAc
Flammability (solid, gas)	Flammable gas.
Upper/lower flammability or explosive limits	
Flammability limit - lower (%)	0.6 %
Flammability limit - upper (%)	7 %
Explosive limit - lower (%)	Not available.
Explosive limit - upper (%)	Not available.
Vapor pressure	< 0.05 mm Hg @ 20°C (dispensed liquid)
Vapor density	4.7 (air = 1)
Relative density	Not available.
Solubility(ies)	
Solubility (water)	< 3 %
Partition coefficient (n-octanol/water)	< 1
Auto-ignition temperature	> 442.4 °F (> 228 °C)
Decomposition temperature	Not established
Viscosity	< 7 cSt
Viscosity temperature	77 °F (25 °C)
Other information	
Heat of combustion	> 30 kJ/g
Percent volatile	92 - 95 %
Specific gravity	0.82 - 0.86 @ 20°C

10. Stability and reactivity

Reactivity	The product is stable and non-reactive under normal conditions of use, storage and transport.
Chemical stability	Material is stable under normal conditions.
Possibility of hazardous reactions	Hazardous polymerization does not occur.
Conditions to avoid	Avoid heat, sparks, open flames and other ignition sources. Avoid temperatures exceeding the flash point. Contact with incompatible materials.

Incompatible materials Strong oxidizing agents.
Hazardous decomposition products Carbon oxides.

11. Toxicological information

Information on likely routes of exposure

Inhalation Vapors have a narcotic effect and may cause headache, fatigue, dizziness and nausea.
Skin contact Causes skin irritation.
Eye contact Causes serious eye irritation.
Ingestion May cause discomfort if swallowed.

Symptoms related to the physical, chemical and toxicological characteristics Irritating to eyes, respiratory system and skin. Symptoms may include stinging, tearing, redness, swelling, and blurred vision. Exposure may cause temporary irritation, redness, or discomfort. Vapors have a narcotic effect and may cause headache, fatigue, dizziness and nausea.

Information on toxicological effects

Acute toxicity Narcotic effects.

Components	Species	Test Results
Distillates Petroleum, Hydrotreated Light (CAS 64742-47-8)		
Acute		
<i>Dermal</i>		
LD50	Rabbit	> 2000 mg/kg > 2000 mg/kg, 24 Hours
<i>Inhalation</i>		
LC50	Cat	> 6.4 mg/l, 6 Hours
	Rat	> 7.5 mg/l, 6 Hours > 4.3 mg/l, 4 Hours > 0.1 mg/l, 8 Hours
<i>Oral</i>		
LD50	Rat	> 5000 mg/kg
Petroleum Oil (CAS 64742-52-5)		
Acute		
<i>Dermal</i>		
LD50	Rabbit	> 2000 mg/kg > 2000 mg/kg, 24 Hours
<i>Inhalation</i>		
LC50	Rat	2.18 mg/l, 4 Hours
<i>Oral</i>		
LD50	Rat	5000 mg/kg
Skin corrosion/irritation	Causes skin irritation.	
Serious eye damage/eye irritation	Causes serious eye irritation.	
Respiratory or skin sensitization		
Respiratory sensitization	Not a respiratory sensitizer.	
Skin sensitization	This product is not expected to cause skin sensitization.	
Germ cell mutagenicity	No data available to indicate product or any components present at greater than 0.1% are mutagenic or genotoxic.	
Carcinogenicity	This product is not considered to be a carcinogen by IARC, ACGIH, NTP, or OSHA.	
OSHA Specifically Regulated Substances (29 CFR 1910.1001-1050)		
Not listed.		
Reproductive toxicity	This product is not expected to cause reproductive or developmental effects.	
Specific target organ toxicity - single exposure	Narcotic effects.	

Specific target organ toxicity - repeated exposure	Based on available data, the classification criteria are not met.
Aspiration hazard	Not likely, due to the form of the product.
Chronic effects	Prolonged inhalation may be harmful.

12. Ecological information

Ecotoxicity The product is not classified as environmentally hazardous. However, this does not exclude the possibility that large or frequent spills can have a harmful or damaging effect on the environment.

Components	Species	Test Results
Distillates Petroleum, Hydrotreated Light (CAS 64742-47-8)		
Aquatic		
Fish	LC50 Rainbow trout, donaldson trout (Oncorhynchus mykiss)	2.9 mg/l, 96 hours

Persistence and degradability Not inherently biodegradable.

Bioaccumulative potential Not available.

Partition coefficient n-octanol / water (log Kow)
LPS@ 2 (Aerosol) < 1

Mobility in soil No data available.

Other adverse effects None known.

13. Disposal considerations

Disposal instructions Consult authorities before disposal. Contents under pressure. Do not puncture, incinerate or crush. Dispose of contents/container in accordance with local/regional/national/international regulations.

Local disposal regulations Dispose in accordance with all applicable regulations.

Hazardous waste code D003: Waste Reactive material

Waste from residues / unused products Dispose of in accordance with local regulations. Empty containers or liners may retain some product residues. This material and its container must be disposed of in a safe manner (see: Disposal instructions).

Contaminated packaging Empty containers should be taken to an approved waste handling site for recycling or disposal. Since emptied containers may retain product residue, follow label warnings even after container is emptied. Do not re-use empty containers.

14. Transport information

DOT

UN number	UN1950
UN proper shipping name	Aerosols, flammable
Transport hazard class(es)	
Class	2.1
Subsidiary risk	-
Label(s)	2.1
Packing group	Not applicable.
Environmental hazards	
Marine pollutant	No
Special precautions for user	Read safety instructions, SDS and emergency procedures before handling. Read safety instructions, SDS and emergency procedures before handling.
Packaging exceptions	306
Packaging non bulk	None
Packaging bulk	None

IATA

UN number	UN1950
UN proper shipping name	Aerosols, flammable
Transport hazard class(es)	
Class	2.1
Subsidiary risk	-
Label(s)	2.1
Packing group	Not applicable.
Environmental hazards	No.
ERG Code	10L

Special precautions for user Read safety instructions, SDS and emergency procedures before handling. Read safety instructions, SDS and emergency procedures before handling.

Other information

Passenger and cargo aircraft Allowed.

Cargo aircraft only Allowed.

IMDG

UN number UN1950

UN proper shipping name AEROSOLS, flammable

Transport hazard class(es)

Class 2.1

Subsidiary risk -

Label(s) 2.1

Packing group Not applicable.

Environmental hazards

Marine pollutant No

EmS Not available.

Special precautions for user Read safety instructions, SDS and emergency procedures before handling. Read safety instructions, SDS and emergency procedures before handling.

Transport in bulk according to Annex II of MARPOL 73/78 and the IBC Code Not applicable.

DOT



IATA; IMDG



15. Regulatory information

US federal regulations This product is a "Hazardous Chemical" as defined by the OSHA Hazard Communication Standard, 29 CFR 1910.1200.

TSCA Section 12(b) Export Notification (40 CFR 707, Subpt. D)

Not regulated.

CERCLA Hazardous Substance List (40 CFR 302.4)

Not listed.

SARA 304 Emergency release notification

Not regulated.

OSHA Specifically Regulated Substances (29 CFR 1910.1001-1050)

Not listed.

Superfund Amendments and Reauthorization Act of 1986 (SARA)

Hazard categories Immediate Hazard - Yes
 Delayed Hazard - No
 Fire Hazard - Yes
 Pressure Hazard - Yes
 Reactivity Hazard - No

SARA 302 Extremely hazardous substance

Not listed.

SARA 311/312 Hazardous chemical Yes

SARA 313 (TRI reporting)

Not regulated.

Other federal regulations**Clean Air Act (CAA) Section 112 Hazardous Air Pollutants (HAPs) List**

Not regulated.

Clean Air Act (CAA) Section 112(r) Accidental Release Prevention (40 CFR 68.130)

Not regulated.

Safe Drinking Water Act (SDWA) Not regulated.

US state regulations**US. California Controlled Substances. CA Department of Justice (California Health and Safety Code Section 11100)**

Not listed.

US. Massachusetts RTK - Substance List

Carbon Dioxide (CAS 124-38-9)

US. New Jersey Worker and Community Right-to-Know Act

Carbon Dioxide (CAS 124-38-9)

US. Pennsylvania Worker and Community Right-to-Know Law

Carbon Dioxide (CAS 124-38-9)

US. Rhode Island RTK

Not regulated.

US. California Proposition 65

California Safe Drinking Water and Toxic Enforcement Act of 1986 (Proposition 65): This material is not known to contain any chemicals currently listed as carcinogens or reproductive toxins.

International Inventories

Country(s) or region	Inventory name	On inventory (yes/no)*
Australia	Australian Inventory of Chemical Substances (AICS)	Yes
Canada	Domestic Substances List (DSL)	Yes
Canada	Non-Domestic Substances List (NDSL)	No
China	Inventory of Existing Chemical Substances in China (IECSC)	No
Europe	European Inventory of Existing Commercial Chemical Substances (EINECS)	Yes
Europe	European List of Notified Chemical Substances (ELINCS)	No
Japan	Inventory of Existing and New Chemical Substances (ENCS)	No
Korea	Existing Chemicals List (ECL)	Yes
New Zealand	New Zealand Inventory	No
Philippines	Philippine Inventory of Chemicals and Chemical Substances (PICCS)	Yes
United States & Puerto Rico	Toxic Substances Control Act (TSCA) Inventory	Yes

*A "Yes" indicates that all components of this product comply with the inventory requirements administered by the governing country(s)

A "No" indicates that one or more components of the product are not listed or exempt from listing on the inventory administered by the governing country(s).

16. Other information, including date of preparation or last revision

Issue date 09-22-2014

Version # 01

Disclaimer

The information provided in this Safety Data Sheet is correct to the best of our knowledge, information and belief at the date of its publication. The information given is designed only as a guidance for safe handling, use, processing, storage, transportation, disposal and release and is not to be considered a warranty or quality specification. The information relates only to the specific material designated and may not be valid for such material used in combination with any other materials or in any process, unless specified in the text.

Revision Information

Product and Company Identification: Product Uses
Composition / Information on Ingredients: Ingredients
Physical & Chemical Properties: Multiple Properties
Ecological Information: Ecotox Property Data
Transport Information: Proper Shipping Name/Packing Group
Regulatory Information: United States
HazReg Data: North America
GHS: Classification



SAFETY DATA SHEET

1. Identification

Product identifier	LPS® All Purpose Anti-Seize
Other means of identification	
Part Number	04108, 04110, 04105
Recommended use	An all-purpose, anti-seize lubricant designed to prevent seizure and galling and resist settling and hardening of welding.
Recommended restrictions	None known.
Manufacturer/Importer/Supplier/Distributor information	
Manufacturer	
Manufacturer	
Company name	LPS Laboratories, a division of Illinois Tool Works, Inc.
Address	4647 Hugh Howell Rd. Tucker, GA 30084
Country	(U.S.A.) Tel: +1 770-243-8800
In Case of Emergency	1-800-424-9300 (inside U.S.) +001 703-527-3887 (outside U.S.)
Website	www.lpslabs.com
E-mail	sds@lpslabs.com

2. Hazard(s) identification

Physical hazards	Not classified.
Health hazards	Not classified.
Environmental hazards	Not classified.
OSHA defined hazards	Not classified.
Label elements	
Hazard symbol	None.
Signal word	None.
Hazard statement	The mixture does not meet the criteria for classification.
Precautionary statement	
Prevention	Observe good industrial hygiene practices.
Response	Wash hands after handling.
Storage	Store away from incompatible materials.
Disposal	Dispose of waste and residues in accordance with local authority requirements.
Hazard(s) not otherwise classified (HNOC)	None known.
Supplemental information	None.

3. Composition/information on ingredients

Mixtures

Chemical name	Common name and synonyms	CAS number	%
Molybdenum (IV) sulfide		1317-33-5	1 - 5
Zinc oxide		1314-13-2	1 - 2

4. First-aid measures

Inhalation	Move to fresh air. Call a physician if symptoms develop or persist.
Skin contact	Wash off with soap and water. Get medical attention if irritation develops and persists.
Eye contact	Rinse with water. Get medical attention if irritation develops and persists.

Ingestion	Rinse mouth. Get medical attention if symptoms occur.
Most important symptoms/effects, acute and delayed	Direct contact with eyes may cause temporary irritation. Exposed individuals may experience eye tearing, redness, and discomfort.
Indication of immediate medical attention and special treatment needed	Treat symptomatically.
General information	Ensure that medical personnel are aware of the material(s) involved, and take precautions to protect themselves.

5. Fire-fighting measures

Suitable extinguishing media	Water fog. Foam. Dry chemical powder. Carbon dioxide (CO ₂).
Unsuitable extinguishing media	Do not use a solid water stream as it may scatter and spread fire.
Specific hazards arising from the chemical	During fire, gases hazardous to health may be formed.
Special protective equipment and precautions for firefighters	Self-contained breathing apparatus and full protective clothing must be worn in case of fire.
Fire fighting equipment/instructions	Use water spray to cool unopened containers.
Specific methods	Use standard firefighting procedures and consider the hazards of other involved materials.
General fire hazards	No unusual fire or explosion hazards noted.

6. Accidental release measures

Personal precautions, protective equipment and emergency procedures	Keep unnecessary personnel away. Do not touch damaged containers or spilled material unless wearing appropriate protective clothing. Use personal protection recommended in Section 8 of the SDS.
Methods and materials for containment and cleaning up	Stop the flow of material, if this is without risk. Prevent entry into waterways, sewer, basements or confined areas. Following product recovery, flush area with water. For waste disposal, see section 13 of the SDS.
Environmental precautions	Avoid discharge into drains, water courses or onto the ground.

7. Handling and storage

Precautions for safe handling	Avoid prolonged exposure. Observe good industrial hygiene practices.
Conditions for safe storage, including any incompatibilities	Store in original tightly closed container. Store away from incompatible materials (see Section 10 of the SDS).

8. Exposure controls/personal protection

Occupational exposure limits

US. OSHA Table Z-1 Limits for Air Contaminants (29 CFR 1910.1000)

Components	Type	Value	Form
Zinc Oxide (CAS 1314-13-2)	PEL	5 mg/m ³	Fume.
		5 mg/m ³	Respirable fraction.
		15 mg/m ³	Total dust.

US. ACGIH Threshold Limit Values

Components	Type	Value	Form
Zinc Oxide (CAS 1314-13-2)	STEL	10 mg/m ³	Respirable fraction.
	TWA	2 mg/m ³	Respirable fraction.

US. NIOSH: Pocket Guide to Chemical Hazards

Components	Type	Value	Form
Zinc Oxide (CAS 1314-13-2)	Ceiling	15 mg/m ³	Dust.
	STEL	10 mg/m ³	Fume.
	TWA	5 mg/m ³	Dust.
		5 mg/m ³	Fume.

Biological limit values No biological exposure limits noted for the ingredient(s).

Appropriate engineering controls	Good general ventilation (typically 10 air changes per hour) should be used. Ventilation rates should be matched to conditions. If applicable, use process enclosures, local exhaust ventilation, or other engineering controls to maintain airborne levels below recommended exposure limits. If exposure limits have not been established, maintain airborne levels to an acceptable level.
Individual protection measures, such as personal protective equipment	
Eye/face protection	Wear safety glasses with side shields (or goggles).
Skin protection	
Hand protection	Wear appropriate chemical resistant gloves.
Other	Wear suitable protective clothing.
Respiratory protection	In case of insufficient ventilation, wear suitable respiratory equipment.
Thermal hazards	Wear appropriate thermal protective clothing, when necessary.
General hygiene considerations	Always observe good personal hygiene measures, such as washing after handling the material and before eating, drinking, and/or smoking. Routinely wash work clothing and protective equipment to remove contaminants.

9. Physical and chemical properties

Appearance	Paste.
Physical state	Solid.
Form	Solid.
Color	Dark grey.
Odor	Hydrocarbon-like.
Odor threshold	Not available.
pH	Not available.
Melting point/freezing point	500 °F (260 °C)
Initial boiling point and boiling range	> 600.8 °F (> 316 °C)
Flash point	> 429.8 °F (> 221.0 °C)
Evaporation rate	Not available.
Flammability (solid, gas)	Not available.
Upper/lower flammability or explosive limits	
Flammability limit - lower (%)	Not available.
Flammability limit - upper (%)	Not available.
Explosive limit - lower (%)	Not available.
Explosive limit - upper (%)	Not available.
Vapor pressure	Not available.
Vapor density	Not available.
Relative density	Not available.
Solubility(ies)	
Solubility (water)	Insoluble
Partition coefficient (n-octanol/water)	Not available.
Auto-ignition temperature	Not available.
Decomposition temperature	Not available.
Viscosity	Not available.
Other information	
Specific gravity	1.19
VOC (Weight %)	Negligible

10. Stability and reactivity

Reactivity	The product is stable and non-reactive under normal conditions of use, storage and transport.
Chemical stability	Material is stable under normal conditions.

Possibility of hazardous reactions	Hazardous polymerization does not occur.
Conditions to avoid	Heat, flames and sparks.
Incompatible materials	Strong oxidizing agents.
Hazardous decomposition products	No hazardous decomposition products are known.

11. Toxicological information

Information on likely routes of exposure

Inhalation	No adverse effects due to inhalation are expected.
Skin contact	Frequent or prolonged contact may defat and dry the skin, leading to discomfort and dermatitis.
Eye contact	Direct contact with eyes may cause temporary irritation.
Ingestion	May cause discomfort if swallowed. However, ingestion is not likely to be a primary route of occupational exposure.

Symptoms related to the physical, chemical and toxicological characteristics
 Direct contact with eyes may cause temporary irritation. Exposure may cause temporary irritation, redness, or discomfort.

Information on toxicological effects

Acute toxicity Expected to be a low hazard for usual industrial or commercial handling by trained personnel.

Components	Species	Test Results
Zinc oxide (CAS 1314-13-2)		
Acute		
<i>Inhalation</i>		
LC50	Mouse	> 5.7 mg/l, 4 Hours
	Rat	> 5700 mg/m3
<i>Oral</i>		
LD50	Mouse	2000 - 5000 mg/kg
	Rat	> 5 g/kg
<i>Other</i>		
LD50	Rat	240 mg/kg

Skin corrosion/irritation Prolonged skin contact may cause temporary irritation.

Serious eye damage/eye irritation Direct contact with eyes may cause temporary irritation.

Respiratory or skin sensitization

Respiratory sensitization	Not a respiratory sensitizer.
Skin sensitization	This product is not expected to cause skin sensitization.

Germ cell mutagenicity No data available to indicate product or any components present at greater than 0.1% are mutagenic or genotoxic.

Carcinogenicity This product is not considered to be a carcinogen by IARC, ACGIH, NTP, or OSHA.

OSHA Specifically Regulated Substances (29 CFR 1910.1001-1050)

Not listed.

Reproductive toxicity This product is not expected to cause reproductive or developmental effects.

Specific target organ toxicity - single exposure Not classified.

Specific target organ toxicity - repeated exposure Not classified.

Aspiration hazard Not likely, due to the form of the product.

Chronic effects None known.

Further information This product has no known adverse effect on human health.

12. Ecological information

Ecotoxicity The product is not classified as environmentally hazardous. However, this does not exclude the possibility that large or frequent spills can have a harmful or damaging effect on the environment.

Components	Species	Test Results
Zinc oxide (CAS 1314-13-2)		
Aquatic		
Fish	LC50	Fathead minnow (<i>Pimephales promelas</i>) 2246 mg/l, 96 hours
Persistence and degradability	No data is available on the degradability of this product.	
Bioaccumulative potential	No data available.	
Mobility in soil	No data available.	
Other adverse effects	None known.	
13. Disposal considerations		
Disposal instructions	Collect and reclaim or dispose in sealed containers at licensed waste disposal site.	
Local disposal regulations	Dispose in accordance with all applicable regulations.	
Hazardous waste code	The waste code should be assigned in discussion between the user, the producer and the waste disposal company.	
Waste from residues / unused products	Dispose of in accordance with local regulations. Empty containers or liners may retain some product residues. This material and its container must be disposed of in a safe manner (see: Disposal instructions).	
Contaminated packaging	Empty containers should be taken to an approved waste handling site for recycling or disposal. Since emptied containers may retain product residue, follow label warnings even after container is emptied.	
14. Transport information		
DOT		
Not regulated as dangerous goods.		
IATA		
Not regulated as dangerous goods.		
IMDG		
Not regulated as dangerous goods.		
Transport in bulk according to Annex II of MARPOL 73/78 and the IBC Code	Not applicable.	
15. Regulatory information		
US federal regulations	All components are on the U.S. EPA TSCA Inventory List. This product is not known to be a "Hazardous Chemical" as defined by the OSHA Hazard Communication Standard, 29 CFR 1910.1200.	
TSCA Section 12(b) Export Notification (40 CFR 707, Subpt. D)		
Not regulated.		
CERCLA Hazardous Substance List (40 CFR 302.4)		
Not listed.		
SARA 304 Emergency release notification		
Not regulated.		
OSHA Specifically Regulated Substances (29 CFR 1910.1001-1050)		
Not listed.		
Superfund Amendments and Reauthorization Act of 1986 (SARA)		
Hazard categories	Immediate Hazard - No Delayed Hazard - No Fire Hazard - No Pressure Hazard - No Reactivity Hazard - No	
SARA 302 Extremely hazardous substance		
Not listed.		
SARA 311/312 Hazardous chemical	No	
SARA 313 (TRI reporting)		
Not regulated.		

Other federal regulations

Clean Air Act (CAA) Section 112 Hazardous Air Pollutants (HAPs) List

Not regulated.

Clean Air Act (CAA) Section 112(r) Accidental Release Prevention (40 CFR 68.130)

Not regulated.

Safe Drinking Water Act (SDWA)

Not regulated.

US state regulations

US. California Controlled Substances. CA Department of Justice (California Health and Safety Code Section 11100)

Not listed.

US. Massachusetts RTK - Substance List

Molybdenum (IV) sulfide (CAS 1317-33-5)

Zinc oxide (CAS 1314-13-2)

US. New Jersey Worker and Community Right-to-Know Act

Zinc oxide (CAS 1314-13-2)

US. Pennsylvania Worker and Community Right-to-Know Law

Zinc oxide (CAS 1314-13-2)

US. Rhode Island RTK

Not regulated.

US. California Proposition 65

California Safe Drinking Water and Toxic Enforcement Act of 1986 (Proposition 65): This material is not known to contain any chemicals currently listed as carcinogens or reproductive toxins.

International Inventories

Country(s) or region	Inventory name	On inventory (yes/no)*
Australia	Australian Inventory of Chemical Substances (AICS)	No
Canada	Domestic Substances List (DSL)	Yes
Canada	Non-Domestic Substances List (NDSL)	No
China	Inventory of Existing Chemical Substances in China (IECSC)	Yes
Europe	European Inventory of Existing Commercial Chemical Substances (EINECS)	Yes
Europe	European List of Notified Chemical Substances (ELINCS)	No
Japan	Inventory of Existing and New Chemical Substances (ENCS)	No
Korea	Existing Chemicals List (ECL)	No
New Zealand	New Zealand Inventory	Yes
Philippines	Philippine Inventory of Chemicals and Chemical Substances (PICCS)	Yes
United States & Puerto Rico	Toxic Substances Control Act (TSCA) Inventory	Yes

*A "Yes" indicates that all components of this product comply with the inventory requirements administered by the governing country(s)

A "No" indicates that one or more components of the product are not listed or exempt from listing on the inventory administered by the governing country(s).

16. Other information, including date of preparation or last revision

Issue date 11-12-2014

Version # 01

Disclaimer LPS Laboratories cannot anticipate all conditions under which this information and its product, or the products of other manufacturers in combination with its product, may be used. It is the user's responsibility to ensure safe conditions for handling, storage and disposal of the product, and to assume liability for loss, injury, damage or expense due to improper use. The information provided in this Safety Data Sheet is correct to the best of our knowledge, information and belief at the date of its publication. The information given is designed only as a guidance for safe handling, use, processing, storage, transportation, disposal and release and is not to be considered a warranty or quality specification. The information relates only to the specific material designated and may not be valid for such material used in combination with any other materials or in any process, unless specified in the text.



Product Name: MOBIL VACTRA OIL HEAVY MEDIUM
 Revision Date: 16 Mar 2015
 Page 1 of 10

SAFETY DATA SHEET

SECTION 1 PRODUCT AND COMPANY IDENTIFICATION

PRODUCT

Product Name: MOBIL VACTRA OIL HEAVY MEDIUM
Product Description: Base Oil and Additives
Product Code: 201560503060, 580407-00, 970015
Intended Use: Lubricant

COMPANY IDENTIFICATION

Supplier: EXXON MOBIL CORPORATION
 22777 Springwoods Village Parkway
 Spring, TX. 77389 USA
24 Hour Health Emergency 609-737-4411
Transportation Emergency Phone 800-424-9300 or 703-527-3887 CHEMTREC
Product Technical Information 800-662-4525
MSDS Internet Address <http://www.exxon.com>, <http://www.mobil.com>

SECTION 2 HAZARDS IDENTIFICATION

This material is not hazardous according to regulatory guidelines (see (M)SDS Section 15).

Other hazard information:

HAZARD NOT OTHERWISE CLASSIFIED (HNOC): None as defined under 29 CFR 1910.1200.

PHYSICAL / CHEMICAL HAZARDS

No significant hazards.

HEALTH HAZARDS

High-pressure injection under skin may cause serious damage. Excessive exposure may result in eye, skin, or respiratory irritation.

ENVIRONMENTAL HAZARDS

No significant hazards.

NFPA Hazard ID:	Health: 0	Flammability: 1	Reactivity: 0
HMIS Hazard ID:	Health: 0	Flammability: 1	Reactivity: 0

NOTE: This material should not be used for any other purpose than the intended use in Section 1 without expert advice. Health studies have shown that chemical exposure may cause potential human health risks which may vary from person to person.



Product Name: MOBIL VACTRA OIL HEAVY MEDIUM
Revision Date: 16 Mar 2015
Page 2 of 10

SECTION 3 COMPOSITION / INFORMATION ON INGREDIENTS

This material is defined as a mixture.

Hazardous Substance(s) or Complex Substance(s) required for disclosure

Name	CAS#	Concentration*	GHS Hazard Codes
2,6-DITERTBUTYL PHENOL	128-39-2	0.1 - < 0.25%	H315, H319(2A), H400(M factor 1), H410(M factor 1)

* All concentrations are percent by weight unless material is a gas. Gas concentrations are in percent by volume.

As per paragraph (i) of 29 CFR 1910.1200, formulation is considered a trade secret and specific chemical identity and exact percentage (concentration) of composition may have been withheld. Specific chemical identity and exact percentage composition will be provided to health professionals, employees, or designated representatives in accordance with applicable provisions of paragraph (i).

SECTION 4 FIRST AID MEASURES

INHALATION

Remove from further exposure. For those providing assistance, avoid exposure to yourself or others. Use adequate respiratory protection. If respiratory irritation, dizziness, nausea, or unconsciousness occurs, seek immediate medical assistance. If breathing has stopped, assist ventilation with a mechanical device or use mouth-to-mouth resuscitation.

SKIN CONTACT

Wash contact areas with soap and water. If product is injected into or under the skin, or into any part of the body, regardless of the appearance of the wound or its size, the individual should be evaluated immediately by a physician as a surgical emergency. Even though initial symptoms from high pressure injection may be minimal or absent, early surgical treatment within the first few hours may significantly reduce the ultimate extent of injury.

EYE CONTACT

Flush thoroughly with water. If irritation occurs, get medical assistance.

INGESTION

First aid is normally not required. Seek medical attention if discomfort occurs.

SECTION 5 FIRE FIGHTING MEASURES

EXTINGUISHING MEDIA

Appropriate Extinguishing Media: Use water fog, foam, dry chemical or carbon dioxide (CO2) to extinguish flames.

Inappropriate Extinguishing Media: Straight Streams of Water

FIRE FIGHTING



Product Name: MOBIL VACTRA OIL HEAVY MEDIUM
 Revision Date: 16 Mar 2015
 Page 3 of 10

Fire Fighting Instructions: Evacuate area. Prevent runoff from fire control or dilution from entering streams, sewers, or drinking water supply. Firefighters should use standard protective equipment and in enclosed spaces, self-contained breathing apparatus (SCBA). Use water spray to cool fire exposed surfaces and to protect personnel.

Hazardous Combustion Products: Smoke, Fume, Sulfur oxides, Aldehydes, Oxides of carbon, Incomplete combustion products

FLAMMABILITY PROPERTIES

Flash Point [Method]: >204°C (399°F) [ASTM D-92]

Flammable Limits (Approximate volume % in air): LEL: 0.9 UEL: 7.0

Autoignition Temperature: N/D

SECTION 6 ACCIDENTAL RELEASE MEASURES

NOTIFICATION PROCEDURES

In the event of a spill or accidental release, notify relevant authorities in accordance with all applicable regulations. US regulations require reporting releases of this material to the environment which exceed the applicable reportable quantity or oil spills which could reach any waterway including intermittent dry creeks. The National Response Center can be reached at (800)424-8802.

PROTECTIVE MEASURES

Avoid contact with spilled material. See Section 5 for fire fighting information. See the Hazard Identification Section for Significant Hazards. See Section 4 for First Aid Advice. See Section 8 for advice on the minimum requirements for personal protective equipment. Additional protective measures may be necessary, depending on the specific circumstances and/or the expert judgment of the emergency responders.

For emergency responders: Respiratory protection: respiratory protection will be necessary only in special cases, e.g., formation of mists. Half-face or full-face respirator with filter(s) for dust/organic vapor or Self Contained Breathing Apparatus (SCBA) can be used depending on the size of spill and potential level of exposure. If the exposure cannot be completely characterized or an oxygen deficient atmosphere is possible or anticipated, SCBA is recommended. Work gloves that are resistant to hydrocarbons are recommended. Gloves made of polyvinyl acetate (PVA) are not water-resistant and are not suitable for emergency use. Chemical goggles are recommended if splashes or contact with eyes is possible. Small spills: normal antistatic work clothes are usually adequate. Large spills: full body suit of chemical resistant, antistatic material is recommended.

SPILL MANAGEMENT

Land Spill: Stop leak if you can do it without risk. Recover by pumping or with suitable absorbent.

Water Spill: Stop leak if you can do it without risk. Confine the spill immediately with booms. Warn other shipping. Remove from the surface by skimming or with suitable absorbents. Seek the advice of a specialist before using dispersants.

Water spill and land spill recommendations are based on the most likely spill scenario for this material; however, geographic conditions, wind, temperature, (and in the case of a water spill) wave and current direction and speed may greatly influence the appropriate action to be taken. For this reason, local experts should be consulted. Note: Local regulations may prescribe or limit action to be taken.

ENVIRONMENTAL PRECAUTIONS

Large Spills: Dike far ahead of liquid spill for later recovery and disposal. Prevent entry into waterways,

sewers, basements or confined areas.

SECTION 7	HANDLING AND STORAGE
------------------	-----------------------------

HANDLING

Prevent small spills and leakage to avoid slip hazard. Material can accumulate static charges which may cause an electrical spark (ignition source). When the material is handled in bulk, an electrical spark could ignite any flammable vapors from liquids or residues that may be present (e.g., during switch-loading operations). Use proper bonding and/or ground procedures. However, bonding and grounds may not eliminate the hazard from static accumulation. Consult local applicable standards for guidance. Additional references include American Petroleum Institute 2003 (Protection Against Ignitions Arising out of Static, Lightning and Stray Currents) or National Fire Protection Agency 77 (Recommended Practice on Static Electricity) or CENELEC CLC/TR 50404 (Electrostatics - Code of practice for the avoidance of hazards due to static electricity).

Static Accumulator: This material is a static accumulator.

STORAGE

The container choice, for example storage vessel, may effect static accumulation and dissipation. Do not store in open or unlabelled containers. Keep away from incompatible materials.

SECTION 8	EXPOSURE CONTROLS / PERSONAL PROTECTION
------------------	--

Exposure limits/standards for materials that can be formed when handling this product: When mists/aerosols can occur the following are recommended: 5 mg/m³ - ACGIH TLV (inhalable fraction), 5 mg/m³ - OSHA PEL.

NOTE: Limits/standards shown for guidance only. Follow applicable regulations.

No biological limits allocated.

ENGINEERING CONTROLS

The level of protection and types of controls necessary will vary depending upon potential exposure conditions. Control measures to consider:
No special requirements under ordinary conditions of use and with adequate ventilation.

PERSONAL PROTECTION

Personal protective equipment selections vary based on potential exposure conditions such as applications, handling practices, concentration and ventilation. Information on the selection of protective equipment for use with this material, as provided below, is based upon intended, normal usage.

Respiratory Protection: If engineering controls do not maintain airborne contaminant concentrations at a level which is adequate to protect worker health, an approved respirator may be appropriate. Respirator selection, use, and maintenance must be in accordance with regulatory requirements, if applicable. Types of respirators to be considered for this material include:

No special requirements under ordinary conditions of use and with adequate ventilation.



Product Name: MOBIL VACTRA OIL HEAVY MEDIUM
 Revision Date: 16 Mar 2015
 Page 5 of 10

For high airborne concentrations, use an approved supplied-air respirator, operated in positive pressure mode. Supplied air respirators with an escape bottle may be appropriate when oxygen levels are inadequate, gas/vapor warning properties are poor, or if air purifying filter capacity/rating may be exceeded.

Hand Protection: Any specific glove information provided is based on published literature and glove manufacturer data. Glove suitability and breakthrough time will differ depending on the specific use conditions. Contact the glove manufacturer for specific advice on glove selection and breakthrough times for your use conditions. Inspect and replace worn or damaged gloves. The types of gloves to be considered for this material include:

No protection is ordinarily required under normal conditions of use.

Eye Protection: If contact is likely, safety glasses with side shields are recommended.

Skin and Body Protection: Any specific clothing information provided is based on published literature or manufacturer data. The types of clothing to be considered for this material include:

No skin protection is ordinarily required under normal conditions of use. In accordance with good industrial hygiene practices, precautions should be taken to avoid skin contact.

Specific Hygiene Measures: Always observe good personal hygiene measures, such as washing after handling the material and before eating, drinking, and/or smoking. Routinely wash work clothing and protective equipment to remove contaminants. Discard contaminated clothing and footwear that cannot be cleaned. Practice good housekeeping.

ENVIRONMENTAL CONTROLS

Comply with applicable environmental regulations limiting discharge to air, water and soil. Protect the environment by applying appropriate control measures to prevent or limit emissions.

SECTION 9	PHYSICAL AND CHEMICAL PROPERTIES
------------------	---

Note: Physical and chemical properties are provided for safety, health and environmental considerations only and may not fully represent product specifications. Contact the Supplier for additional information.

GENERAL INFORMATION

Physical State: Liquid
Color: Amber
Odor: Characteristic
Odor Threshold: N/D

IMPORTANT HEALTH, SAFETY, AND ENVIRONMENTAL INFORMATION

Relative Density (at 15 °C): 0.882
Flammability (Solid, Gas): N/A
Flash Point [Method]: >204°C (399°F) [ASTM D-92]
Flammable Limits (Approximate volume % in air): LEL: 0.9 UEL: 7.0
Autoignition Temperature: N/D
Boiling Point / Range: > 316°C (600°F)
Decomposition Temperature: N/D
Vapor Density (Air = 1): > 2 at 101 kPa
Vapor Pressure: < 0.013 kPa (0.1 mm Hg) at 20 °C
Evaporation Rate (n-butyl acetate = 1): N/D



Product Name: MOBIL VACTRA OIL HEAVY MEDIUM
Revision Date: 16 Mar 2015
Page 6 of 10

pH: N/A
Log Pow (n-Octanol/Water Partition Coefficient): > 3.5
Solubility in Water: Negligible
Viscosity: >68 cSt (68 mm²/sec) at 40 °C
Oxidizing Properties: See Hazards Identification Section.

OTHER INFORMATION

Freezing Point: N/D
Melting Point: N/A
Pour Point: -15°C (5°F)
DMSO Extract (mineral oil only), IP-346: < 3 %wt

SECTION 10 STABILITY AND REACTIVITY

REACTIVITY: See sub-sections below.

STABILITY: Material is stable under normal conditions.

CONDITIONS TO AVOID: Excessive heat. High energy sources of ignition.

MATERIALS TO AVOID: Strong oxidizers

HAZARDOUS DECOMPOSITION PRODUCTS: Material does not decompose at ambient temperatures.

POSSIBILITY OF HAZARDOUS REACTIONS: Hazardous polymerization will not occur.

SECTION 11 TOXICOLOGICAL INFORMATION

INFORMATION ON TOXICOLOGICAL EFFECTS

Hazard Class	Conclusion / Remarks
Inhalation	
Acute Toxicity: No end point data for material.	Minimally Toxic. Based on assessment of the components.
Irritation: No end point data for material.	Negligible hazard at ambient/normal handling temperatures.
Ingestion	
Acute Toxicity: No end point data for material.	Minimally Toxic. Based on assessment of the components.
Skin	
Acute Toxicity: No end point data for material.	Minimally Toxic. Based on assessment of the components.
Skin Corrosion/Irritation: No end point data for material.	Negligible irritation to skin at ambient temperatures. Based on assessment of the components.
Eye	
Serious Eye Damage/Irritation: No end point data for material.	May cause mild, short-lasting discomfort to eyes. Based on assessment of the components.
Sensitization	
Respiratory Sensitization: No end point data for material.	Not expected to be a respiratory sensitizer.
Skin Sensitization: No end point data for material.	Not expected to be a skin sensitizer. Based on assessment of the components.
Aspiration: Data available.	Not expected to be an aspiration hazard. Based on



Product Name: MOBIL VACTRA OIL HEAVY MEDIUM

Revision Date: 16 Mar 2015

Page 7 of 10

	physico-chemical properties of the material.
Germ Cell Mutagenicity: No end point data for material.	Not expected to be a germ cell mutagen. Based on assessment of the components.
Carcinogenicity: No end point data for material.	Not expected to cause cancer. Based on assessment of the components.
Reproductive Toxicity: No end point data for material.	Not expected to be a reproductive toxicant. Based on assessment of the components.
Lactation: No end point data for material.	Not expected to cause harm to breast-fed children.
Specific Target Organ Toxicity (STOT)	
Single Exposure: No end point data for material.	Not expected to cause organ damage from a single exposure.
Repeated Exposure: No end point data for material.	Not expected to cause organ damage from prolonged or repeated exposure. Based on assessment of the components.

OTHER INFORMATION

Contains:

Base oil severely refined: Not carcinogenic in animal studies. Representative material passes IP-346, Modified Ames test, and/or other screening tests. Dermal and inhalation studies showed minimal effects; lung non-specific infiltration of immune cells, oil deposition and minimal granuloma formation. Not sensitizing in test animals.

The following ingredients are cited on the lists below: None.

--REGULATORY LISTS SEARCHED--

1 = NTP CARC

3 = IARC 1

5 = IARC 2B

2 = NTP SUS

4 = IARC 2A

6 = OSHA CARC

SECTION 12 ECOLOGICAL INFORMATION

The information given is based on data available for the material, the components of the material, and similar materials.

ECOTOXICITY

Material -- Not expected to be harmful to aquatic organisms.

MOBILITY

Base oil component -- Low solubility and floats and is expected to migrate from water to the land. Expected to partition to sediment and wastewater solids.

PERSISTENCE AND DEGRADABILITY

Biodegradation:

Base oil component -- Expected to be inherently biodegradable

BIOACCUMULATION POTENTIAL

Base oil component -- Has the potential to bioaccumulate, however metabolism or physical properties may reduce the bioconcentration or limit bioavailability.



Product Name: MOBIL VACTRA OIL HEAVY MEDIUM
Revision Date: 16 Mar 2015
Page 8 of 10

SECTION 13	DISPOSAL CONSIDERATIONS
-------------------	--------------------------------

Disposal recommendations based on material as supplied. Disposal must be in accordance with current applicable laws and regulations, and material characteristics at time of disposal.

DISPOSAL RECOMMENDATIONS

Product is suitable for burning in an enclosed controlled burner for fuel value or disposal by supervised incineration at very high temperatures to prevent formation of undesirable combustion products. Protect the environment. Dispose of used oil at designated sites. Minimize skin contact. Do not mix used oils with solvents, brake fluids or coolants.

REGULATORY DISPOSAL INFORMATION

RCRA Information: The unused product, in our opinion, is not specifically listed by the EPA as a hazardous waste (40 CFR, Part 261D), nor is it formulated to contain materials which are listed as hazardous wastes. It does not exhibit the hazardous characteristics of ignitability, corrosivity or reactivity and is not formulated with contaminants as determined by the Toxicity Characteristic Leaching Procedure (TCLP). However, used product may be regulated.

Empty Container Warning Empty Container Warning (where applicable): Empty containers may contain residue and can be dangerous. Do not attempt to refill or clean containers without proper instructions. Empty drums should be completely drained and safely stored until appropriately reconditioned or disposed. Empty containers should be taken for recycling, recovery, or disposal through suitably qualified or licensed contractor and in accordance with governmental regulations. **DO NOT PRESSURISE, CUT, WELD, BRAZE, SOLDER, DRILL, GRIND, OR EXPOSE SUCH CONTAINERS TO HEAT, FLAME, SPARKS, STATIC ELECTRICITY, OR OTHER SOURCES OF IGNITION. THEY MAY EXPLODE AND CAUSE INJURY OR DEATH.**

SECTION 14	TRANSPORT INFORMATION
-------------------	------------------------------

LAND (DOT): Not Regulated for Land Transport

LAND (TDG): Not Regulated for Land Transport

SEA (IMDG): Not Regulated for Sea Transport according to IMDG-Code

Marine Pollutant: No

AIR (IATA): Not Regulated for Air Transport

SECTION 15	REGULATORY INFORMATION
-------------------	-------------------------------



Product Name: MOBIL VACTRA OIL HEAVY MEDIUM
 Revision Date: 16 Mar 2015
 Page 9 of 10

OSHA HAZARD COMMUNICATION STANDARD: This material is not considered hazardous in accordance with OSHA HazCom 2012, 29 CFR 1910.1200.

Listed or exempt from listing/notification on the following chemical inventories: AICS, DSL, IECSC, TSCA

EPCRA SECTION 302: This material contains no extremely hazardous substances.

SARA (311/312) REPORTABLE HAZARD CATEGORIES: None.

SARA (313) TOXIC RELEASE INVENTORY: This material contains no chemicals subject to the supplier notification requirements of the SARA 313 Toxic Release Program.

The following ingredients are cited on the lists below: None.

--REGULATORY LISTS SEARCHED--

1 = ACGIH ALL	6 = TSCA 5a2	11 = CA P65 REPRO	16 = MN RTK
2 = ACGIH A1	7 = TSCA 5e	12 = CA RTK	17 = NJ RTK
3 = ACGIH A2	8 = TSCA 6	13 = IL RTK	18 = PA RTK
4 = OSHA Z	9 = TSCA 12b	14 = LA RTK	19 = RI RTK
5 = TSCA 4	10 = CA P65 CARC	15 = MI 293	

Code key: CARC=Carcinogen; REPRO=Reproductive

SECTION 16	OTHER INFORMATION
------------	-------------------

N/D = Not determined, N/A = Not applicable

KEY TO THE H-CODES CONTAINED IN SECTION 3 OF THIS DOCUMENT (for information only):

H315: Causes skin irritation; Skin Corr/Irritation, Cat 2
 H319(2A): Causes serious eye irritation; Serious Eye Damage/Irr, Cat 2A
 H400: Very toxic to aquatic life; Acute Env Tox, Cat 1
 H410: Very toxic to aquatic life with long lasting effects; Chronic Env Tox, Cat 1

THIS SAFETY DATA SHEET CONTAINS THE FOLLOWING REVISIONS:

Updates made in accordance with implementation of GHS requirements.

 The information and recommendations contained herein are, to the best of ExxonMobil's knowledge and belief, accurate and reliable as of the date issued. You can contact ExxonMobil to insure that this document is the most current available from ExxonMobil. The information and recommendations are offered for the user's consideration and examination. It is the user's responsibility to satisfy itself that the product is suitable for the intended use. If buyer repackages this product, it is the user's responsibility to insure proper health, safety and other necessary information is included with and/or on the container. Appropriate warnings and safe-handling procedures should be provided to



Product Name: MOBIL VACTRA OIL HEAVY MEDIUM
Revision Date: 16 Mar 2015
Page 10 of 10

handlers and users. Alteration of this document is strictly prohibited. Except to the extent required by law, re-publication or retransmission of this document, in whole or in part, is not permitted. The term, "ExxonMobil" is used for convenience, and may include any one or more of ExxonMobil Chemical Company, Exxon Mobil Corporation, or any affiliates in which they directly or indirectly hold any interest.

Internal Use Only

MHC: 0B, 0B, 0, 0, 0, 0

PPEC: A

DGN: 2006644XUS (1017266)

Copyright 2002 Exxon Mobil Corporation, All rights reserved

SAF-T-LOK

International Corporation

Material Safety Data Sheet

SAF-T-EZE MOLY GRADE ANTI-SEIZE

Issue Date: 10/30/14

SECTION I - PRODUCT AND COMPANY INFORMATION

Product Name:	MOLY GRADE ANTI-SEIZE
Product Type:	Lubricating Grease
Part Numbers:	80855, 80837, 80822, 80878, 80853, 6V-4876
Hazard Rating:	Health: 1 Fire: 1 Reactivity: 0
Company Identification:	SAF-T-LOK International Corporation 300 EISENHOWER LANE NORTH LOMBARD, IL 60148
Contact:	Chris Michaels
Telephone/ Fax:	(630) 495-2001
Emergency Phone (24 Hour):	(703) 527-3887
Chemtrec (24 Hour):	(800) 424-9300, (703) 527-3887
Preparer:	Ind. Hygiene Department
Internet:	www.saftlok.com
Product Class:	Mixture
DOT Hazard Class:	N/A
Shipping Name:	Unrestricted

SECTION II - INGREDIENT AND HAZARD INFORMATION

Components	CAS Number	Percent
Graphite	7782-42-5	20 - 30
Hydrotreated Heavy Napthenic Distillate	64742-52-5	40 - 50
Molybdenum Disulfide	1317-33-5	20 - 30

SECTION III - HAZARD IDENTIFICATION AND EMERGENCY OVERVIEW

EMERGENCY OVERVIEW

Physical appearance:	Paste	<u>HMS</u>	
Physical color:	Black	Health:	1
Odor:	Mild / Inoffensive	Flammability:	1
		Reactivity:	0
		Personal Protection:	B

WARNING; MAY CAUSE: EYE IRRITATION
SKIN IRRITATION
RESPIRATORY TRACT IRRITATION
MAY IRRITATE EXISTING ALLERGIC SKIN CONDITIONS

Relative routes of entry: Skin, Inhalation, Eyes, Ingestion

Skin Contact: Usually no effect, however, as with any chemical, prolonged, excessive, or repeated exposure may cause mild to moderate skin irritation, exhibited by redness, drying and cracking of unprotected skin.
Eye Contact: May irritate with slight pain and redness.

Respiratory/ Inhalation: Usually none, however, as with any chemical product, some irritation may occur.

Ingestion: Amounts transferred to mouth by fingers, etc, during normal operation should not cause injury.

Medical conditions generally aggravated by exposure: None known, however any chemical product may enhance allergies already present in certain individuals.

This product does not require exceptional labeling due to the evaluation procedure of the "General Classification guideline for preparations of the EU".

SECTION IV – FIRST AID INSTRUCTIONS

Skin Contact: Remove contaminated clothing. Wash affected area with soap and rinse with plenty of water. Get medical attention if symptoms occur. Wash clothing before reuse.

Eye Contact: Flush with water for at least 15 minutes holding eyelid open. Get medical attention if symptoms persist.

Respiratory / Inhalation: Remove to fresh air, if symptoms develop get medical attention.

Ingestion: Do not induce vomiting. Obtain medical attention if symptoms develop.

SECTION V – FIRE FIGHTING INSTRUCTIONS

Flash Point:	360°F (C.O.C.)
Unusual Fire and Explosion Hazards:	None
Flammable Limits:	LEL: N/A, UEL: N/A
Extinguishing Media:	Carbon Dioxide, Foam, Dry Chemicals
Fire Fighting Procedures:	Air mask and procedures for fighting chemical fires. Do not inhale gases.

SECTION VI -ACCIDENTAL RELEASE MEASURES

Special Precautions: None known. Follow general precautions shown below.

Environmental precautions: Prevent material from entering floor drains, sewers, or any bodies of water.

Clean up methods: Scoop up into waste container or soak up with absorbent material. Store in a closed container until disposal. Dispose of material according to regulations.

SECTION VII - HANDLING AND STORAGE

Handling: No special precautions necessary if used properly. Avoid contact with eyes, skin, and clothing. Avoid breathing vapors. Wash hands thoroughly at mealtime and end of shift.

Storage:	Isolated storage facility/ warehouse not required. Store in a cool, dry location (60-90°F) in a well-ventilated area in original container. Keep container tightly closed when not in use.
Personal Protection:	Wear personal protective equipment as outlined in Section VIII of this MSDS.

SECTION VIII – EXPOSURE CONTROLS AND PERSONAL PROTECTION

Respiratory Protection:	No respiratory protection required, but normal good ventilation is recommended. Forced ventilation may be required if concentrations exceed normal use exposure.
Skin Protection:	Not required, but if desired, use impermeable gloves (neoprene, butyl rubber, natural rubber), as necessary to avoid skin contact, as well as proper clothing or plastic apron. Wash hands before eating, drinking, or using restroom.
Eye Protection:	Not required if application method is proper. Avoid contact with eyes.
Eye Washes:	Eye wash stations should be located within 100 feet or 10 second walk of the work area.

SECTION IX - PHYSICAL AND CHEMICAL PROPERTIES

Physical state:	Paste
Color:	Black
Odor:	Mild/ Inoffensive
Boiling Point:	600°F (316°C)
Melting Point:	Not determined
Flash Point:	360°F
Self-inflammability:	Is not self-igniting
Explosion danger:	Not explosive
Specific Gravity:	1.4
Vapor Density (Air = 1):	N/D
Vapor Pressure (mm Hg.):	< 0.1 @70°F
pH:	Not determined
Evaporation Rate:	Not determined
Solubility in Water:	Insoluble
VOC (Organic solvents):	0.1%
Percent Solids:	50

SECTION X – STABILITY AND REACTIVITY

Stability:	Stable
Hazardous Polymerization:	Will not occur
Hazardous decomposition byproducts:	None if used and stored according to specifications
Conditions to avoid:	Strong oxidizing agents

SECTION XI – TOXICOLOGICAL INFORMATION

No harmful effects have been determined if product is used and handled according to specifications.

This product is not subject to classification according to the calculation method of the General EC Classification Guidelines for Preparations.

Sensitization:	None known
Eye Irritant:	Not determined
Skin Irritant:	Not determined
Carcinogen:	No

SECTION XII – ECOLOGICAL DATA

Water Hazard: Do not allow entry into drains or surface water
Class 2 per German Regulation

SECTION XIII – DISPOSAL CONSIDERATIONS

Recommended method of disposal: Small quantities can be disposed with normal household waste.
Disposal must be made according to official regulations.

EPA Hazardous Waste Number; Not an RCRA hazardous waste.

SECTION XIV – SHIPPING AND TRANSPORTATION INFORMATION

U.S. Department of Transportation Ground (49 CFR

Proper Shipping Name: Unrestricted
Hazard Class or Division: None
Identification Number: None
Packing Group: None

International Air Transportation (OCAO/IATA):

Proper Shipping Name: Unrestricted
Hazard Class or Division: None
Identification Number: None
Packing Group: None

Water Transportation (IMO/IMDG):

Proper Shipping Name: Environmentally hazardous substance, liquid, N.O. S.
Hazard Class or Division: IMDG Class 9
Identification Number: None
Packing Group: None
Marine Pollutant: Yes

ADR/RID-GGVS/E Class (cross border) Unrestricted

SECTION XV – REGULATORY INFORMATION

United States Regulatory Information

TSCA 8 (b) Inventory Status: All components are listed or are exempt from listing on the Toxic Substances Control Act Inventory

Canada Regulatory Information

CEPA DSL/NDL Status: All components are listed on or are exempt from listing on the Domestic Substances List.

SECTION XVI – OTHER INFORMATION

Revision date: 10/30/14
By: Human Resource Department

DISCLAIMER: The information on this material safety data sheet represents our current data and best opinion as to the proper use in handling of this product under normal conditions. Any use of the product which is not in conformance with this data sheet or which involves using the product in combination with any other product or any other process is the responsibility of the user. SAF-T-LOK International Corporation specifically disclaims all warranties, express or implied, including warranties of merchantability and fitness for a particular purpose, arising from sale or use of SAF-T-LOK International Corporation products.

Product Name: Nook Industries E-900L Liquid
(Part number NLU-1004)
Revision Date: 23 Sept 2013
Page 1 of 7



MATERIAL SAFETY DATA SHEET

SECTION 1 PRODUCT AND COMPANY IDENTIFICATION

PRODUCT

Product Name: Nook Industries E-900L Ball Screw Lubricant Liquid
Product Description: Synthetic Base Stocks and Additives
Product Code: 202050401020, 494237-00, 971870
Intended Use: Ball screw lubrication

COMPANY IDENTIFICATION

Supplier: **NOOK INDUSTRIES**
 4950 EAST 49th STREET
 CLEVELAND, OH 44125

24 Hour Health Emergency 800-255-3924
MSDS Requests 800-321-7800
MSDS Internet Address <http://www.nookindustries.com/r/msds>

SECTION 2 COMPOSITION / INFORMATION ON INGREDIENTS

REPORTABLE HAZARDOUS SUBSTANCE(S) OR COMPLEX SUBSTANCE(S)

NAME	CAS#	CONCENTRATION*
1-NAPHTHYLAMINE, N-PHENYL-	90-30-2	1%

* All concentrations are percent by weight unless material is a gas. Gas concentrations are in percent by volume.

SECTION 3 HAZARDS IDENTIFICATION

This material is not considered to be hazardous according to regulatory guidelines (see (MSDS Section 15)).

POTENTIAL HEALTH EFFECTS

Excessive exposure may result in eye, skin, or respiratory irritation. This product is not expected to produce adverse health effects under normal conditions of use and with appropriate personal hygiene practices. Product may decompose at elevated temperatures or under fire conditions and give off irritating and/or harmful (carbon monoxide) gases/vapors/fumes. Symptoms from acute exposure to these decomposition products in confined spaces may include headache, nausea, eye, nose, and throat irritation. High-pressure injection under skin may cause serious damage.

NFPA HAZARD ID:	HEALTH: 1	FLAMMABILITY: 1	REACTIVITY: 0
HMIS Hazard ID:	Health: 1	Flammability: 1	Reactivity: 0

NOTE: This material should not be used for any other purpose than the intended use in Section 1 without expert advice. Health studies have shown that chemical exposure may cause potential human health risks which may vary from person to person.

Product Name: Nook Industries E-900L Liquid
(Part number NLU-1004)
Revision Date: 23 Sept 2013
Page 2 of 7



SECTION 4 FIRST AID MEASURES

INHALATION

Remove from further exposure. For those providing assistance, avoid exposure to yourself or others. Use adequate respiratory protection. If respiratory irritation, dizziness, nausea, or unconsciousness occurs, seek immediate medical assistance. If breathing has stopped, assist ventilation with a mechanical device or use mouth-to-mouth resuscitation.

SKIN CONTACT

Wash contact areas with soap and water. If product is injected into or under the skin, or into any part of the body, regardless of the appearance of the wound or its size, the individual should be evaluated immediately by a physician as a surgical emergency. Even though initial symptoms from high pressure injection may be minimal or absent, early surgical treatment within the first few hours may significantly reduce the ultimate extent of injury.

EYE CONTACT

Flush thoroughly with water. If irritation occurs, get medical assistance.

INGESTION

Seek immediate medical attention.

SECTION 5 FIRE FIGHTING MEASURES

EXTINGUISHING MEDIA

Appropriate Extinguishing Media: Use water fog, foam, dry chemical or carbon dioxide (CO₂) to extinguish flames.

Inappropriate Extinguishing Media: Straight Streams of Water

FIRE FIGHTING

Fire Fighting Instructions: Evacuate area. Prevent runoff from fire control or dilution from entering streams, sewers, or drinking water supply. Firefighters should use standard protective equipment and in enclosed spaces, self-contained breathing apparatus (SCBA). Use water spray to cool fire exposed surfaces and to protect personnel.

Hazardous Combustion Products: Aldehydes, Smoke, Fume, Oxides of carbon, Sulfur oxides, Incomplete combustion products, Trimethylol propane phosphate

FLAMMABILITY PROPERTIES

Flash Point [Method]: 210C (410F) [ASTM D-92]

Flammable Limits (Approx vol % in air): LEL: N/D UEL: N/D

Autoignition Temperature: N/D

Product Name: Nook Industries E-900L Liquid
(Part number NLU-1004)
Revision Date: 23 Sept 2013
Page 3 of 7



SECTION 6 ACCIDENTAL RELEASE MEASURES

NOTIFICATION PROCEDURES

In the event of a spill or accidental release, notify relevant authorities in accordance with all applicable regulations. US regulations require reporting releases of this material to the environment which exceed the applicable reportable quantity or oil spills which could reach any waterway including intermittent dry creeks. The National Response Center can be reached at (800)424-8802.

SPILL MANAGEMENT

Land Spill: Stop leak if you can do it without risk. Recover by pumping or with suitable absorbent.

Water Spill: Stop leak if you can do it without risk. Confine the spill immediately with booms. Warn other shipping. Remove from the surface by skimming or with suitable absorbents. Seek the advice of a specialist before using dispersants.

Water spill and land spill recommendations are based on the most likely spill scenario for this material; however, geographic conditions, wind, temperature, (and in the case of a water spill) wave and current direction and speed may greatly influence the appropriate action to be taken. For this reason, local experts should be consulted. Note: Local regulations may prescribe or limit action to be taken.

ENVIRONMENTAL PRECAUTIONS

Large Spills: Dike far ahead of liquid spill for later recovery and disposal. Prevent entry into waterways, sewers, basements or confined areas.

SECTION 7 HANDLING AND STORAGE

HANDLING

It has been determined that during fires neurotoxic trimethylol propane phosphate may be formed, which when inhaled may impair central nervous system function. In addition, thermally decomposed (and cooled) residues may be neurotoxic. Prevent small spills and leakage to avoid slip hazard.

Static Accumulator: This material is a static accumulator.

STORAGE

Do not store in open or unlabelled containers.

SECTION 8 EXPOSURE CONTROLS / PERSONAL PROTECTION

NOTE: Limits/standards shown for guidance only. Follow applicable regulations.

ENGINEERING CONTROLS

The level of protection and types of controls necessary will vary depending upon potential exposure conditions. Control measures to consider:

No special requirements under ordinary conditions of use and with adequate ventilation.

PERSONAL PROTECTION

Personal protective equipment selections vary based on potential exposure conditions such as applications, handling practices, concentration and ventilation. Information on the selection of protective equipment for use with this material, as provided below, is based upon intended, normal usage.



Respiratory Protection: If engineering controls do not maintain airborne contaminant concentrations at a level which is adequate to protect worker health, an approved respirator may be appropriate. Respirator selection, use, and maintenance must be in accordance with regulatory requirements, if applicable. Types of respirators to be considered for this material include:

No special requirements under ordinary conditions of use and with adequate ventilation.

For high airborne concentrations, use an approved supplied-air respirator, operated in positive pressure mode. Supplied air respirators with an escape bottle may be appropriate when oxygen levels are inadequate, gas/vapor warning properties are poor, or if air purifying filter capacity/rating may be exceeded.

Hand Protection: Any specific glove information provided is based on published literature and glove manufacturer data. Glove suitability and breakthrough time will differ depending on the specific use conditions. Contact the glove manufacturer for specific advice on glove selection and breakthrough times for your use conditions. Inspect and replace worn or damaged gloves. The types of gloves to be considered for this material include:

No protection is ordinarily required under normal conditions of use.

Eye Protection: If contact is likely, safety glasses with side shields are recommended.

Skin and Body Protection: Any specific clothing information provided is based on published literature or manufacturer data. The types of clothing to be considered for this material include:

No skin protection is ordinarily required under normal conditions of use. In accordance with good industrial hygiene practices, precautions should be taken to avoid skin contact.

Specific Hygiene Measures: Always observe good personal hygiene measures, such as washing after handling the material and before eating, drinking, and/or smoking. Routinely wash work clothing and protective equipment to remove contaminants. Discard contaminated clothing and footwear that cannot be cleaned. Practice good housekeeping.

ENVIRONMENTAL CONTROLS

See Sections 6, 7, 12, 13.

SECTION 9 PHYSICAL AND CHEMICAL PROPERTIES

Typical physical and chemical properties are given below. Consult the Supplier in Section 1 for additional data.

GENERAL INFORMATION

Physical State:	Liquid
Color:	Amber
Odor:	Characteristic
Odor Threshold:	N/D

IMPORTANT HEALTH, SAFETY, AND ENVIRONMENTAL INFORMATION

Relative Density (at 15 C):	0.96
Flash Point [Method]:	210C (410F) [ASTM D-92]
Flammable Limits (Approx vol % in air):	LEL: N/D UEL: N/D
Autoignition Temperature:	N/D
Boiling Point / Range:	> 316C (600F)
Vapor Density (Air = 1):	N/D
Vapor Pressure:	< 0.013 kPa (0.1 mm Hg) at 20 C
Evaporation Rate (n-butyl acetate = 1):	N/D
pH:	N/A

Product Name: Nook Industries E-900L Liquid
(Part number NLU-1004)
Revision Date: 23 Sept 2013
Page 5 of 7



Log Pow (n-Octanol/Water Partition Coefficient): N/A
Solubility in Water: Negligible
Viscosity: 13.3 cSt (13.3 mm²/sec) at 40 C | 3 cSt (3 mm²/sec) at 100C
Oxidizing Properties: See Sections 3, 15, 16.

OTHER INFORMATION

Freezing Point: N/D
Melting Point: N/A
Pour Point: -62°C (-80°F)

SECTION 10 STABILITY AND REACTIVITY

Stability: material is stable under normal conditions.
Conditions To Avoid: excessive heat. High energy sources of ignition.
Materials To Avoid: Strong oxidizers
Hazardous Decomposition Products: material does not decompose at ambient temperatures.
Hazardous Polymerization: will not occur.

SECTION 11 TOXICOLOGICAL INFORMATION

ACUTE TOXICITY

ROUTE OF EXPOSURE	CONCLUSION / REMARKS
Inhalation	
Toxicity: No end point data.	Not determined.
Irritation: No end point data.	Negligible hazard at ambient/normal handling temperatures. Based on assessment of the components.
Ingestion	
Toxicity: No end point data.	Minimally Toxic. Based on assessment of the components.
Skin	
Toxicity: No end point data.	Minimally Toxic. Based on assessment of the components.
Irritation: No end point data.	Negligible irritation to skin at ambient temperatures. Based on assessment of the components.
Eye	
Irritation: No end point data.	May cause mild, short-lasting discomfort to eyes. Based on assessment of the components.

CHRONIC/OTHER EFFECTS

Contains:

N-phenyl-1-naphthylamine: A single oral overexposure may lead to signs of cyanosis, including headache, shallow respiration, dizziness, confusion, fall in blood pressure, convulsions, coma, jaundice.

Product Name: Nook Industries E-900L Liquid
(Part number NLU-1004)
Revision Date: 23 Sept 2013
Page 6 of 7



Anemia may occur later. Repeated exposure in laboratory animals caused liver and kidney damage and depression of bone marrow activity. Hematuria may occur due to bladder and kidney irritation. Genotoxic in vitro.

Phenyl-alpha-naphthylamine (PAN): Undiluted PAN is a skin sensitizer. Human testing with lubricants containing 1.0% PAN caused no reactions indicative of sensitization.

Additional information is available by request.

The following ingredients are cited on the lists below: None.

--REGULATORY LISTS SEARCHED--		
1 = NTP CARC	3 = IARC 1	5 = IARC 2B
2 = NTP SUS	4 = IARC 2A	6 = OSHA CARC

SECTION 12 ECOLOGICAL INFORMATION

The information given is based on data available for the material, the components of the material, and similar materials.

ECOTOXICITY

Material -- Not expected to be harmful to aquatic organisms.

Material -- Not expected to demonstrate chronic toxicity to aquatic organisms.

SECTION 13 DISPOSAL CONSIDERATIONS

Disposal recommendations based on material as supplied. Disposal must be in accordance with current applicable laws and regulations, and material characteristics at time of disposal.

DISPOSAL RECOMMENDATIONS

Dispose of waste at an appropriate treatment & disposal facility in accordance with applicable laws and regulations, and product characteristics at time of disposal.

REGULATORY DISPOSAL INFORMATION

RCRA Information: The unused product, in our opinion, is not specifically listed by the EPA as a hazardous waste (40 CFR, Part 261D), nor is it formulated to contain materials which are listed as hazardous wastes. It does not exhibit the hazardous characteristics of ignitability, corrosivity or reactivity and is not formulated with contaminants as determined by the Toxicity Characteristic Leaching Procedure (TCLP). However, used product may be regulated.

Empty Container Warning Empty Container Warning (where applicable): Empty containers may contain residue and can be dangerous. Do not attempt to refill or clean containers without proper instructions. Empty drums should be completely drained and safely stored until appropriately reconditioned or disposed. Empty containers should be taken for recycling, recovery, or disposal through suitably qualified or licensed contractor and in accordance with governmental regulations. DO NOT PRESSURISE, CUT, WELD, BRAZE, SOLDER, DRILL, GRIND, OR EXPOSE SUCH CONTAINERS TO HEAT, FLAME, SPARKS, STATIC ELECTRICITY, OR OTHER SOURCES OF IGNITION. THEY MAY EXPLODE AND CAUSE INJURY OR DEATH.

Product Name: Nook Industries E-900L Liquid
(Part number NLU-1004)
Revision Date: 23 Sept 2013
Page 7 of 7



SECTION 14 TRANSPORT INFORMATION

LAND (DOT) : Not Regulated for Land Transport
LAND (TDG) : Not Regulated for Land Transport
SEA (IMDG) : Not Regulated for Sea Transport according to IMDG-Code
AIR (IATA) : Not Regulated for Air Transport

SECTION 15 REGULATORY INFORMATION

OSHA HAZARD COMMUNICATION STANDARD: When used for its intended purposes, this material is not classified as hazardous in accordance with OSHA 29 CFR 1910.1200.

NATIONAL CHEMICAL INVENTORY LISTING: PICCS, AICS, KECI, TSCA, EINECS

EPCRA: This material contains no extremely hazardous substances.

SARA (311/312) REPORTABLE HAZARD CATEGORIES: None.

SARA (313) TOXIC RELEASE INVENTORY: This material contains no chemicals subject to the supplier notification requirements of the SARA 313 Toxic Release Program.

The Following Ingredients are Cited on the Lists Below:

CHEMICAL NAME	CAS NUMBER	LIST CITATIONS
Diphenylamine	122-39-4	5

--REGULATORY LISTS SEARCHED--			
1 = ACGIH ALL	6 = TSCA 5a2	11 = CA P65 REPRO	16 = MN RTK
2 = ACGIH A1	7 = TSCA 5e	12 = CA RTK	17 = NJ RTK
3 = ACGIH A2	8 = TSCA 6	13 = IL RTK	18 = PA RTK
4 = OSHA Z	9 = TSCA 12b	14 = LA RTK	19 = RI RTK
5 = TSCA 4	10 = CA P65 CARC	15 = MI 293	

Code key: CARC=Carcinogen; REPRO=Reproductive

SECTION 16 OTHER INFORMATION

N/D = Not determined, N/A = Not applicable

###

The information and recommendations contained herein are, to the best of Nook Industries' knowledge and belief, accurate and reliable as of the date issued. You can contact Nook Industries to insure that this document is the most current available from Nook Industries. The information and recommendations are offered for the user's consideration and examination. It is the user's responsibility to satisfy itself that the product is suitable for the intended use. If buyer repackages this product, it is the user's responsibility to insure proper health, safety and other necessary information is included with and/or on the container. Appropriate warnings and safe-handling procedures should be provided to handlers and users. Alteration of this document is strictly prohibited. Except to the extent required by law, re-publication or retransmission of this document, in whole or in part, is not permitted.

Product Name: Nook Industries PAG-1 Grease
(Part number NLU-1001)
Revision Date: 23 Sept 2013
Page 1 of 8



MATERIAL SAFETY DATA SHEET

SECTION 1 PRODUCT AND COMPANY IDENTIFICATION

PRODUCT

Product Name: Omniguard
MSDS Number: 778589
Intended Use: Lubricating Grease

COMPANY IDENTIFICATION

Supplier Nook Industries
4950 East 49th Street
Cleveland, Oh 44125
24 Health Emergency: Chemtrec: 800-424-9300 (24 Hours)
MSDS Requests: 800-321-7800
MSDS Internet Address <http://www.nookindustries.com/r/msds>

SECTION 2 HAZARDS IDENTIFICATION

EMERGENCY OVERVIEW

Appearance: Tan
Physical Form: Semi-Solid
Odor: Petroleum

POTENTIAL HEALTH EFFECTS

Eye: Eye irritant. Contact may cause stinging, watering, redness, and swelling.
Skin: Contact may cause mild skin irritation including redness and a burning sensation. Repeated exposure may cause skin dryness or cracking. No information available on skin absorption.
Inhalation (Breathing): No information available on acute toxicity. Inhalation is not an expected route of exposure.
Ingestion (Swallowing): Low degree of toxicity by ingestion.
Signs and Symptoms: Inhalation of oil mists or vapors generated at elevated temperatures may cause respiratory irritation. Accidental ingestion can result in minor irritation of the digestive tract, nausea and diarrhea.
Pre-Existing Medical Conditions: Conditions which may be aggravated by exposure include eye disorders and skin disorders.

See Section 11 for additional Toxicity Information.

SECTION 3 COMPOSITION / INFORMATION ON INGREDIENTS

COMPONENT	CASRN	CONCENTRATION ¹
Lubricant Base Oil (Petroleum)	VARIOUS	50 - 80
Additives	PROPRIETARY	15 - 40
Calcium Dodecylbenzenesulfonate	26264-06-2	1 - 3

¹ All concentrations are percent by weight unless ingredient is a gas. Gas concentrations are in percent by volume.

Product Name: Nook Industries PAG-1 Grease
(Part number NLU-1001)
Revision Date: 23 Sept 2013
Page 2 of 8



SECTION 4 FIRST AID MEASURES

Eye Contact: For direct contact, remove contact lenses if present and easy to do. Immediately hold eyelids apart and flush the affected eye(s) with clean water for at least 15 minutes. Seek immediate medical attention.

Skin Contact: Remove contaminated shoes and clothing and cleanse affected area(s) thoroughly by washing with mild soap and water or a waterless hand cleaner. If irritation or redness develops and persists, seek medical attention. If product is injected into or under the skin, or into any part of the body, regardless of the appearance of the wound or its size, the individual should be evaluated immediately by a physician. (see Note to Physician)

Inhalation (Breathing): If respiratory symptoms develop, move victim away from source of exposure and into fresh air in a position comfortable for breathing. If symptoms persist, seek medical attention.

Ingestion (Swallowing): First aid is not normally required; however, if swallowed and symptoms develop, seek medical attention.

Notes to Physician: High-pressure hydrocarbon injection injuries may produce substantial necrosis of underlying tissue despite an innocuous appearing external wound. These injuries often require extensive emergency surgical debridement and all injuries should be evaluated by a specialist in order to assess the extent of injury. Early surgical treatment within the first few hours may significantly reduce the ultimate extent of injury.

SECTION 5 FIRE-FIGHTING MEASURES

NFPA 704 Hazard Class

Health: 1

Flammability: 1

Instability: 0

(0-Minimal, 1-Slight, 2-Moderate, 3-Serious, 4-Severe)

Unusual Fire & Explosion Hazards: This material may burn, but will not ignite readily. If container is not properly cooled, it can rupture in the heat of a fire.

Extinguishing Media: Dry chemical, carbon dioxide, foam, or water spray is recommended. Water or foam may cause frothing of materials heated above 212°F / 100°C. Carbon dioxide can displace oxygen. Use caution when applying carbon dioxide in confined spaces. Simultaneous use of foam and water on the same surface is to be avoided as water destroys the foam.

Fire Fighting Instructions: For fires beyond the initial stage, emergency responders in the immediate hazard area should wear protective clothing. When the potential chemical hazard is unknown, in enclosed or confined spaces, a self contained breathing apparatus should be worn. In addition, wear other appropriate protective equipment as conditions warrant (see Section 8).

Isolate immediate hazard area and keep unauthorized personnel out. Stop spill/release if it can be done safely. Move undamaged containers from immediate hazard area if it can be done safely. Water spray may be useful in minimizing or dispersing vapors and to protect personnel. Cool equipment exposed to fire with water, if it can be done safely. Avoid spreading burning liquid with water used for cooling purposes.

Hazardous Combustion Products: Combustion may yield smoke, carbon monoxide, and other products of incomplete combustion.

Oxides of sulfur, nitrogen or phosphorus may also be formed.

See Section 9 for Flammable Properties including Flash Point and Flammable (Explosive) Limits



SECTION 6 ACCIDENTAL RELEASE MEASURES

Personal Precautions: This material may burn, but will not ignite readily. Keep all sources of ignition away from spill/release. Stay upwind and away from spill/release. Avoid direct contact with material. For larges spillages, notify persons down wind of the spill/release, isolate immediate hazard area and keep unauthorized personnel out. Wear appropriate protective equipment, including respiratory protection, as conditions warrant (see Section 8). See Sections 2 and 7 for additional information on hazards and precautionary measures.

Environmental Precautions: If spill/release in excess of EPA reportable quantity (see Section 15) is made into the environment, immediately notify the National Response Center (phone number 800-424-8802). Stop spill/release if it can be done safely. Prevent spilled material from entering sewers, storm drains, other unauthorized drainage systems, and natural waterways. Use water sparingly to minimize environmental contamination and reduce disposal requirements. If spill occurs on water notify appropriate authorities and advise shipping of any hazard. Spills into or upon navigable waters, the contiguous zone, or adjoining shorelines that cause a sheen or discoloration on the surface of the water, may require notification of the National Response Center (phone number 800-424-8802).

Methods for Containment and Clean-Up: Notify relevant authorities in accordance with all applicable regulations. Immediate cleanup of any spill is recommended. Dike far ahead of spill for later recovery or disposal. Absorb spill with inert material such as sand or vermiculite, and place in suitable container for disposal. If spilled on water remove with appropriate methods (e.g. skimming, booms or absorbents). In case of soil contamination, remove contaminated soil for remediation or disposal, in accordance with local regulations.

SECTION 7 HANDLING AND STORAGE

Precautions for safe handling: Keep away from flames and hot surfaces. Wear eye/face protection. Wash thoroughly after handling.

Use good personal hygiene practices and wear appropriate personal protective equipment.

High pressure injection of hydrocarbon fuels, hydraulic oils or greases under the skin may have serious consequences even though no symptoms or injury may be apparent. This can happen accidentally when using high pressure equipment such as high pressure grease guns, fuel injection apparatus or from pinhole leaks in tubing of high pressure hydraulic oil equipment.

Do not enter confined spaces such as tanks or pits without following proper entry procedures such as ASTM D-4276 and 29CFR 1910.146. Do not wear contaminated clothing or shoes.

Conditions for safe storage: Keep container(s) tightly closed and properly labeled. Use and store this material in cool, dry, well-ventilated area away from heat and all sources of ignition. Store only in approved containers. Keep away from any incompatible material (see Section 10). Protect container(s) against physical damage.

"Empty" containers retain residue and may be dangerous. Do not pressurize, cut, weld, braze, solder, drill, grind, or expose such containers to heat, flame, sparks, or other sources of ignition. They may explode and cause injury or death. "Empty" drums should be completely drained, properly bunged, and promptly shipped to the supplier or a drum reconditioner. All containers should be disposed of in an environmentally safe manner and in accordance with governmental regulations. Before working on or in tanks which contain or have contained this material, refer to OSHA regulations, ANSI Z49.1, and other references pertaining to cleaning, repairing, welding, or other contemplated operations.

Product Name: Nook Industries PAG-1 Grease
(Part number NLU-1001)
Revision Date: 23 Sept 2013
Page 4 of 8



SECTION 8 EXPOSURE CONTROLS / PERSONAL PROTECTION

COMPONENT	US-ACGIH	OSHA	OTHER
Lubricant Base Oil (Petroleum)	TWA: 5mg/m ³ STEL: 10 mg/m ³ as Oil Mist, if generated	TWA: 5 mg/m ³ as Oil Mist, if generated	---

NOTE: State, local or other agencies or advisory groups may have established more stringent limits. Consult an industrial hygienist or similar professional, or your local agencies, for further information.

Engineering controls: If current ventilation practices are not adequate to maintain airborne concentrations below the established exposure limits, additional engineering controls may be required.

Eye/Face Protection: The use of eye protection that meets or exceeds ANSI Z.87.1 is recommended to protect against potential eye contact, irritation, or injury. Depending on conditions of use, a face shield may be necessary.

Skin/Hand Protection: The use of gloves impervious to the specific material handled is advised to prevent skin contact. Users should check with manufacturers to confirm the breakthrough performance of their products. Suggested protective materials: Nitrile

Respiratory Protection: Respiratory protection is not normally required under intended conditions of use. Emergencies or conditions that could result in significant airborne exposures may require the use of NIOSH approved respiratory protection. An industrial hygienist or other appropriate health and safety professional should be consulted for specific guidance under these situations.

Other Protective Equipment: Eye wash and quick-drench shower facilities should be available in the work area. Thoroughly clean shoes and wash contaminated clothing before reuse.

Suggestions provided in this section for exposure control and specific types of protective equipment are based on readily available information. Users should consult with the specific manufacturer to confirm the performance of their protective equipment. Specific situations may require consultation with industrial hygiene, safety, or engineering professionals.

SECTION 9 PHYSICAL AND CHEMICAL PROPERTIES

NOTE: Unless otherwise stated, values are determined at 20°C (68°F) and 760 mm Hg (1 atm). Data represent typical values and are not intended to be specifications.

Appearance:	Tan
Physical Form:	Semi-Solid
Odor:	Petroleum
Odor Threshold:	No data
pH:	Not applicable
Vapor Pressure:	<0.1 mm Hg
Vapor Density (air=1):	> 5
Initial Boiling Point/Range:	No data
Melting/Freezing Point:	No data
Solubility in Water:	Insoluble
Solubility in Other Solvents:	Soluble
Partition Coefficient	
(n-octanol/water) (Kow):	No data
Specific Gravity (water=1):	0.9943 @ 60°F (15.6°C)
Bulk Density:	8.29 lbs/gal



Evaporation Rate (nBuAc=1):	<1
Flash Point:	464°F / 240°C
Test Method:	Cleveland Open Cup (COC), ASTM D92
Lower Explosive Limits (vol % in air):	No data
Upper Explosive Limits (vol % in air):	No data
Auto-ignition Temperature:	No data

SECTION 10 STABILITY AND REACTIVITY

Stability: Stable under normal ambient and anticipated conditions of use.

Conditions to Avoid: Extended exposure to high temperatures can cause decomposition. Avoid all possible sources of ignition.

Materials to Avoid (Incompatible Materials): Avoid contact with strong oxidizing agents and strong reducing agents.

Hazardous Decomposition Products: Not anticipated under normal conditions of use.

Hazardous Polymerization: Not known to occur.

SECTION 11 TOXICOLOGICAL INFORMATION

CHRONIC TOXICITY:

Lubricant Base Oil (Petroleum)

Carcinogenicity: The petroleum base oils contained in this product have been highly refined by a variety of processes including severe hydrocracking/hydroprocessing to reduce aromatics and improve performance characteristics. All of the oils meet the IP-346 criteria of less than 3 percent PAH's and are not considered carcinogens by NTP, IARC, or OSHA.

ACUTE TOXICITY:

COMPONENT	ORAL LD50	DERMAL LD50	INHALATION LC50
Lubricant Base Oil (Petroleum)	> 5 g/kg	> 2 g/kg	> 5 mg/L
Calcium Dodecylbenzenesulfonate	1,300 mg/kg	No data	No data

SECTION 12 ECOLOGICAL INFORMATION

Ecotoxicity: Experimental studies show that acute aquatic toxicity values are greater than 1000 mg/l. These values are consistent with the predicted aquatic toxicity of these substances based on their hydrocarbon compositions. However, there is insufficient information available on the toxicity of the thickening agents used in greases. Should therefore be regarded as capable of causing long term adverse effects in the aquatic environment.

Mobility: Volatilization to air is not expected to be a significant fate process due to the low vapor pressure of this material.

Components may behave differently in the aquatic environment with soaps dispersing and dissolving to some extent in water while the hydrocarbons will float on the surface due to their low water solubility. The hydrocarbon portion would be expected to show low mobility in soil and water. The major environmental fate would be expected to be biodegradation.

Product Name: Nook Industries PAG-1 Grease
(Part number NLU-1001)
Revision Date: 23 Sept 2013
Page 6 of 8



Persistence and degradability: The base oil constituents of greases are expected to be inherently, but not readily biodegradable.

Some of the thickening agents may be readily biodegradable.

Bioaccumulation Potential: Log Kow values measured for the hydrocarbon components of this material range from 4 to over 6, and therefore regarded as having the potential to bioaccumulate. In practice, metabolic processes may reduce bioconcentration.

SECTION 13 DISPOSAL CONSIDERATIONS

The generator of a waste is always responsible for making proper hazardous waste determinations and needs to consider state and local requirements in addition to federal regulations.

This material, if discarded as produced, would not be a federally regulated RCRA "listed" hazardous waste and is not believed to exhibit characteristics of hazardous waste. See Sections 7 and 8 for information on handling, storage and personal protection and Section 9 for physical/chemical properties. It is possible that the material as produced contains constituents which are not required to be listed in the MSDS but could affect the hazardous waste determination. Additionally, use which results in chemical or physical change of this material could subject it to regulation as a hazardous waste.

This material under most intended uses would become "Used Oil" due to contamination by physical or chemical impurities. Whenever possible, Recycle Used Oil in accordance with applicable federal and state or local regulations. Container contents should be completely used and containers should be emptied prior to discard.

SECTION 14 TRANSPORTATION INFORMATION

U.S. DEPARTMENT OF TRANSPORTATION (DOT)

Shipping Description: Not regulated

NOTE: If shipped by land in a packaging having a capacity of 3,500 gallons or more, the provisions of 49 CFR, Part 130 apply. (Contains oil)

INTERNATIONAL MARITIME DANGEROUS GOODS (IMDG)

Shipping Description: Not regulated

NOTE: U.S. DOT compliance requirements may apply. See 49 CFR 171.22, 23 & 25.

INTERNATIONAL CIVIL AVIATION ORG.

INTERNATIONAL AIR TRANSPORT ASSOC. (ICAO/IATA)

UN/ID #: Not regulated

NOTE: U.S. DOT compliance requirements may apply. See 49 CFR 171.22, 23 & 24.

	LTD. QTY	PASSENGER AIRCRAFT	CARGO AIRCRAFT ONLY
Packaging Instruction #:	---	---	---
Max. Net Qty. Per Package:	---	---	---
Packaging Instruction # after 12/31/2010:			

Product Name: Nook Industries PAG-1 Grease
(Part number NLU-1001)
Revision Date: 23 Sept 2013
Page 7 of 8



SECTION 15 REGULATORY INFORMATION

CERCLA/SARA

Section 302 Extremely Hazardous Substances and TPQs (in pounds):

This material does not contain any chemicals subject to the reporting requirements of SARA 302 and 40 CFR 372.

CERCLA/SARA

Section 311/312 (Title III Hazard Categories)

Acute Health: Yes
Chronic Health: No
Fire Hazard: No
Pressure Hazard: No
Reactive Hazard: No

COMPONENT	RQ
Calcium Dodecylbenzenesulfonate	1000 lb

CALIFORNIA PROPOSITION 65

WARNING: This material may contain detectable quantities of the following chemicals, known to the State of California to cause cancer, birth defects or other reproductive harm, and which may be subject to the requirements of California Proposition 65 (CA Health & Safety Code Section 25249.5):

COMPONENT	TYPE OF TOXICITY
1-Naphthylamine	Cancer
2-Naphthylamine	Cancer

CANADIAN REGULATIONS

This product has been classified in accordance with the hazard criteria of the Controlled Products Regulations (CPR) and the MSDS contains all the information required by the Regulations.

WHMIS Hazard Class D2B

NATIONAL CHEMICAL INVENTORIES:

All components are either listed on the USTSCA Inventory, or are not regulated under TSCA.

All components are either on the DSL, or are exempt from DSL listing requirements.

U.S. Export Control Classification Number: EAR99

Product Name: Nook Industries PAG-1 Grease
(Part number NLU-1001)
Revision Date: 23 Sept 2013
Page 8 of 8



SECTION 16 OTHER INFORMATION

Date of Issue:	06-Aug-2010
Status:	FINAL
Previous Issue Date:	27-Aug-2007
MSDS Number:	778589

Guide to Abbreviations:

ACGIH = American Conference of Governmental Industrial Hygienists

CASRN = Chemical Abstracts Service Registry Number

CEILING = Ceiling Limit (15 minutes)

CERCLA = The Comprehensive Environmental Response, Compensation, and Liability Act

EPA = Environmental Protection Agency

IARC = International Agency for Research on Cancer

LEL = Lower Explosive Limit

NE = Not Established

NFPA = National Fire Protection Association

NTP = National Toxicology Program

OSHA = Occupational Safety and Health Administration

PEL = Permissible Exposure Limit (OSHA)

SARA = Superfund Amendments and Reauthorization Act

STEL = Short Term Exposure Limit (15 minutes)

TLV = Threshold Limit Value (ACGIH)

TWA = Time Weighted Average (8 hours)

UEL = Upper Explosive Limit

WHMIS = Worker Hazardous Materials Information System (Canada)



MATERIAL SAFETY DATA SHEET

76 Unax AW 32, 46, 68

1. PRODUCT AND COMPANY IDENTIFICATION

Product Name: 76 Unax AW 32, 46, 68
Product Code: 4641032000, 4642046000, 4643068000
Synonyms: 76 Unax AW 32
 76 Unax AW 46
 76 Unax AW 68
Intended Use: Industrial oil
Chemical Family: Petroleum hydrocarbon
Responsible Party: 76 Lubricants
 A Division of ConocoPhillips
 600 N. Dairy Ashford
 Houston, TX 77079-1175
For Additional MSDSs 800-762-0942
Technical Information: 800-435-7761

The intended use of this product is indicated above. If any additional use is known, please contact us at the Technical Information number listed.

EMERGENCY OVERVIEW

24 Hour Emergency Telephone Numbers:

Spill, Leak, Fire or Accident California Poison Control System: (800) 356-3129
 Call CHEMTREC
 North America: (800)424-9300
 Others: (703)527-3887 (collect)

Health Hazards/Precautionary Measures: Avoid contact with eyes, skin and clothing. Wash thoroughly after handling.

Physical Hazards/Precautionary Measures: Keep away from all sources of ignition.

Appearance: Clear and bright
Physical form: Liquid
Odor: Mild petroleum

NFPA Hazard Class:

Health: 1 (Slight)
 Flammability: 1 (Slight)
 Reactivity: 0 (Least)

HMIS Hazard Class

Health: 1 (Slight)
 Flammability: 1 (Slight)
 Physical Hazard: 0 (Least)

2. COMPOSITION/INFORMATION ON INGREDIENTS

<u>HAZARDOUS COMPONENTS</u>	<u>% WEIGHT</u>	<u>EXPOSURE GUIDELINE</u>		
		<u>Limits</u>	<u>Agency</u>	<u>Type</u>
Zinc Compound CAS# Proprietary	<1	Not Established		

<u>OTHER COMPONENTS</u>	<u>% WEIGHT</u>	<u>EXPOSURE GUIDELINE</u>		
		<u>Limits</u>	<u>Agency</u>	<u>Type</u>
Lubricant Base Oil (Petroleum) CAS# Various	>99	(See: Oil Mist, If Generated)		
Additives CAS# Proprietary	<1	Not Established		

<u>REFERENCE</u>	<u>EXPOSURE GUIDELINE</u>		
	<u>Limits</u>	<u>Agency</u>	<u>Type</u>
Oil Mist, If Generated CAS# None	5 mg/m3	ACGIH	TWA
	10 mg/m3	ACGIH	STEL
	5 mg/m3	OSHA	TWA
	2500 mg/m3	NIOSH	IDLH
	5 mg/m3	NOHSC	TWA

The base oil for this product can be a mixture of any of the following highly refined petroleum streams: CAS 64741-88-4; CAS 64741-89-5; CAS 64741-96-4; CAS 64741-97-5; CAS 64742-01-4; CAS 64742-52-5; CAS 64742-53-6; CAS 64742-54-7; CAS 64742-55-8; CAS 64742-56-9; CAS 64742-57-0; CAS 64742-62-7; CAS 64742-63-8; CAS 64742-65-0; CAS 72623-85-9; CAS 72623-86-0; CAS 72623-87-1

Note: State, local or other agencies or advisory groups may have established more stringent limits. Consult an industrial hygienist or similar professional, or your local agencies, for further information.

1%=10,000 PPM.

All components are listed on the TSCA inventory.

3. HAZARDS IDENTIFICATION

Potential Health Effects:

Eye: Contact may cause mild eye irritation including stinging, watering, and redness.

Skin: Contact may cause mild skin irritation including redness, and a burning sensation. Prolonged or repeated contact can worsen irritation by causing drying and cracking of the skin leading to dermatitis (inflammation). No harmful effects from skin absorption are expected.

Inhalation (Breathing): No information available. Studies by other exposure routes suggest a low degree of toxicity by inhalation.

Ingestion (Swallowing): No harmful effects expected from ingestion.

Signs and Symptoms: Effects of overexposure may include irritation of the nose and throat, irritation of the digestive tract, nausea and diarrhea.

Cancer: Inadequate evidence available to evaluate the cancer hazard of this material. See Section 11 for carcinogenicity information of individual components, if any.

Target Organs: No data available for this material.

Developmental: No data available for this material.

Pre-Existing Medical Conditions: Conditions aggravated by exposure may include skin disorders.

4. FIRST AID MEASURES

Eye: If irritation or redness develops, move victim away from exposure and into fresh air. Flush eyes with clean water. If symptoms persist, seek medical attention.

Skin: Wipe material from skin and remove contaminated shoes and clothing. Cleanse affected area(s) thoroughly by washing with mild soap and water and, if necessary, a waterless skin cleanser. If irritation or redness develops and persists, seek medical attention.

Inhalation (Breathing): If respiratory symptoms develop, move victim away from source of exposure and into fresh air. If symptoms persist, seek medical attention. If victim is not breathing, clear airway and immediately begin artificial respiration. If breathing difficulties develop, oxygen should be administered by qualified personnel. Seek immediate medical attention.

Ingestion (Swallowing): First aid is not normally required; however, if swallowed and symptoms develop, seek medical attention.

Note To Physicians: High-pressure hydrocarbon injection injuries may produce substantial necrosis of underlying tissue despite an innocuous appearing external wound. Often these injuries require extensive emergency surgical debridement and all injuries should be evaluated by a specialist in order to assess the extent of injury.

5. FIRE FIGHTING MEASURES

Flammable Properties:

- Flash Point: >384°F/>196°C (COC)
- OSHA Flammability Class: Not applicable
- LEL/UEL%: No Data
- Autoignition Temperature: No Data

Unusual Fire & Explosion Hazards: This material may burn, but will not ignite readily. If container is not properly cooled, it can rupture in the heat of a fire.

Extinguishing Media: Dry chemical, carbon dioxide, foam, or water spray is recommended. Water or foam may cause frothing of materials heated above 212°F. Carbon dioxide can displace oxygen. Use caution when applying carbon dioxide in confined spaces.

Fire Fighting Instructions: For fires beyond the incipient stage, emergency responders in the immediate hazard area should wear bunker gear. When the potential chemical hazard is unknown, in enclosed or confined spaces, or when explicitly required by DOT, a self contained breathing apparatus should be worn. In addition, wear other appropriate protective equipment as conditions warrant (see Section 8).

Isolate immediate hazard area, keep unauthorized personnel out. Stop spill/release if it can be done with minimal risk. Move undamaged containers from immediate hazard area if it can be done with minimal risk.

Water spray may be useful in minimizing or dispersing vapors and to protect personnel. Cool equipment exposed to fire with water, if it can be done with minimal risk. Avoid spreading burning liquid with water used for cooling purposes.

6. ACCIDENTAL RELEASE MEASURES

This material may burn, but will not ignite readily. Keep all sources of ignition away from spill/release. Stay upwind and away from spill/release. Notify persons down wind of the spill/release, isolate immediate hazard area and keep unauthorized personnel out. Stop spill/release if it can be done with minimal risk. Wear appropriate protective equipment including respiratory protection as conditions warrant (see Section 8).

Prevent spilled material from entering sewers, storm drains, other unauthorized drainage systems, and natural waterways. Dike far ahead of spill for later recovery or disposal. Spilled material may be absorbed into an appropriate absorbent material.

Notify fire authorities and appropriate federal, state, and local agencies. Immediate cleanup of any spill is recommended. If spill of any amount is made into or upon navigable waters, the contiguous zone, or adjoining shorelines, notify the National Response Center (phone number 800-424-8802).

7. HANDLING AND STORAGE

Handling: Do not enter confined spaces such as tanks or pits without following proper entry procedures such as ASTM D-4276 and 29CFR 1910.146. The use of appropriate respiratory protection is advised when concentrations exceed any established exposure limits (see Sections 2 and 8).

Do not wear contaminated clothing or shoes. Use good personal hygiene practices.

High pressure injection of hydrocarbon fuels, hydraulic oils or greases under the skin may have serious consequences even though no symptoms or injury may be apparent. This can happen accidentally when using high pressure equipment such as high pressure grease guns, fuel injection apparatus or from pinhole leaks in tubing of high pressure hydraulic oil equipment.

"Empty" containers retain residue and may be dangerous. Do not pressurize, cut, weld, braze, solder, drill, grind, or expose such containers to heat, flame, sparks, or other sources of ignition. They may explode and cause injury or death. "Empty" drums should be completely drained, properly bunged, and promptly shipped to the supplier or a drum reconditioner. All containers should be disposed of in an environmentally safe manner and in accordance with governmental regulations.

Before working on or in tanks which contain or have contained this material, refer to OSHA regulations, ANSI Z49.1 and other references pertaining to cleaning, repairing, welding, or other contemplated operations.

Storage: Keep container(s) tightly closed. Use and store this material in cool, dry, well-ventilated areas away from heat and all sources of ignition. Store only in approved containers. Keep away from any incompatible material (see Section 10). Protect container(s) against physical damage.

8. EXPOSURE CONTROLS/PERSONAL PROTECTION

Engineering controls: If current ventilation practices are not adequate to maintain airborne concentrations below the established exposure limits (see Section 2), additional engineering controls may be required.

Personal Protective Equipment (PPE):

Respiratory: A NIOSH certified air purifying respirator with a Type 95 (R or P) particulate filter may be used under conditions where airborne concentrations are expected to exceed exposure limits (see Section 2).

Protection provided by air purifying respirators is limited (see manufacturer's respirator selection guide). Use a NIOSH approved self-contained breathing apparatus (SCBA) or equivalent operated in a pressure demand or other positive pressure mode if there is potential for an uncontrolled release, exposure levels are not known, or any other circumstances where air purifying respirators may not provide adequate protection. A respiratory protection program that meets OSHA's 29 CFR 1910.134 and ANSI Z88.2 requirements must be followed whenever workplace conditions warrant a respirator's use.

Skin: The use of gloves impervious to the specific material handled is advised to prevent skin contact and possible irritation (see manufacturers literature for information on permeability).

Eye/Face: Approved eye protection to safeguard against potential eye contact, irritation, or injury is recommended. Depending on conditions of use, a face shield may be necessary.

Other Protective Equipment: A source of clean water should be available in the work area for flushing eyes and skin. Impervious clothing should be worn as needed.

Suggestions for the use of specific protective materials are based on readily available published data. Users should check with specific manufacturers to confirm the performance of their products.

9. PHYSICAL AND CHEMICAL PROPERTIES

Note: Unless otherwise stated, values are determined at 20°C (68°F) and 760 mm Hg (1 atm).

Appearance: Clear and bright

Physical State: Liquid

Odor: Mild petroleum

pH: Not applicable

Vapor Pressure (mm Hg): <1

Vapor Density (air=1): >1

Boiling Point/Range: No Data

Freezing/Melting Point: <-27°F / <-33°C

Solubility in Water: Negligible

Specific Gravity: 0.855-0.871

Percent Volatile: Negligible

Evaporation Rate (nBuAc=1): Negligible

Viscosity: 22-68 cSt @ 40°C / 4.3-8.7 cSt @ 100°C

Bulk Density: 7.13-7.26 lb/gal

Flash Point: >384°F / >196°C (COC)

Flammable/Explosive Limits (%): No Data

10. STABILITY AND REACTIVITY

Stability: Stable under normal ambient and anticipated storage and handling conditions of temperature and pressure.

Conditions To Avoid: Extended exposure to high temperatures can cause decomposition.

Materials to Avoid (Incompatible Materials): Avoid contact with strong oxidizing agents.

Hazardous Decomposition Products: Combustion can yield carbon, nitrogen, sulfur, phosphorus, and zinc oxides.

Hazardous Polymerization: Will not occur.

11. TOXICOLOGICAL INFORMATION

Lubricant Base Oil (Petroleum) (CAS# Various)

Carcinogenicity: The petroleum base oils contained in this product have been highly refined by a variety of processes including solvent extraction, hydrotreating, and dewaxing to remove aromatics and improve performance characteristics. None of the oils used are listed as a carcinogen by NTP, IARC, or OSHA.

12. ECOLOGICAL INFORMATION

Not evaluated at this time

(MSDS: 722330)

Page 6 of 7

13. DISPOSAL CONSIDERATIONS

This material under most intended uses would become used oil due to contamination by physical or chemical impurities. RECYCLE ALL USED OIL. While being recycled, used oil is regulated by 40 CFR 279. Use resulting in chemical or physical change or contamination may also subject it to regulation as hazardous waste. Under federal regulations, used oil is a solid waste managed under 40 CFR 279. However, in California, used oil is managed as hazardous waste until tested to show it is not hazardous. Consult state and local regulations regarding the proper handling of used oil. In the case of used oil, the intent to discard it may cause the used oil to be regulated as hazardous waste.

Contents should be completely used and containers emptied prior to discard. Rinsate may be considered a RCRA hazardous waste and must be disposed of with care and in compliance with federal, state and local regulations. Large empty containers, such as drums, should be returned to the distributor or a drum reconditioner. To assure proper disposal of small empty containers, consult with state and local regulations and disposal authorities.

14. TRANSPORT INFORMATION

DOT Shipping Description: Not classified as hazardous

15. REGULATORY INFORMATION

EPA SARA 311/312 (Title III Hazard Categories):

Acute Health: No
Chronic Health: No
Fire Hazard: No
Pressure Hazard: No
Reactive Hazard: No

SARA 313 and 40 CFR 372:

This material contains the following chemicals subject to the reporting requirements of SARA 313 and 40 CFR 372:

Component	CAS Number	Weight %
Zinc Compound	Proprietary	<1

California Proposition 65:

Warning: This material contains the following chemicals which are known to the State of California to cause cancer, birth defects or other reproductive harm, and are subject to the requirements of California Proposition 65 (CA Health & Safety Code Section 25249.5):

--None Known--

Carcinogen Identification:

This material has not been identified as a carcinogen by NTP, IARC, or OSHA. See Section 11 for carcinogenicity information of individual components, if any.

EPA (CERCLA) Reportable Quantity:

--None--

Canada - Domestic Substances List: Listed

WHMIS Class:

Not regulated

This product has been classified in accordance with the hazard criteria of the Controlled Products Regulations (CPR) and the MSDS contains all the information required by the CPR.

16. OTHER INFORMATION

Issue Date: 02/06/03

(MSDS: 722330)

Page 7 of 7

Previous Issue Date: 01/01/02
Product Code: 4641032000, 4642046000, 4643068000
Revised Sections: New Format
Previous Product Code: 4641032000
MSDS Number: 722330
Status: Final

Disclaimer of Expressed and Implied Warranties:

The information presented in this Material Safety Data Sheet is based on data believed to be accurate as of the date this Material Safety Data Sheet was prepared. **HOWEVER, NO WARRANTY OF MERCHANTABILITY, FITNESS FOR ANY PARTICULAR PURPOSE, OR ANY OTHER WARRANTY IS EXPRESSED OR IS TO BE IMPLIED REGARDING THE ACCURACY OR COMPLETENESS OF THE INFORMATION PROVIDED ABOVE, THE RESULTS TO BE OBTAINED FROM THE USE OF THIS INFORMATION OR THE PRODUCT, THE SAFETY OF THIS PRODUCT, OR THE HAZARDS RELATED TO ITS USE.** No responsibility is assumed for any damage or injury resulting from abnormal use or from any failure to adhere to recommended practices. The information provided above, and the product, are furnished on the condition that the person receiving them shall make their own determination as to the suitability of the product for their particular purpose and on the condition that they assume the risk of their use. In addition, no authorization is given nor implied to practice any patented invention without a license.

 **CLIMAX**
Family of Brands

 **BORTECH**

 **CALDER**
TESTERS

H&S TOOL