

VERSATILITY. DURABILITY. SAFETY.

The latest innovation in Climax's line of flange facers, this series of OD Mount Flange Facers set a new standard in safety, versatility, durability and performance, quickly machining all 7 flange types on the market today.

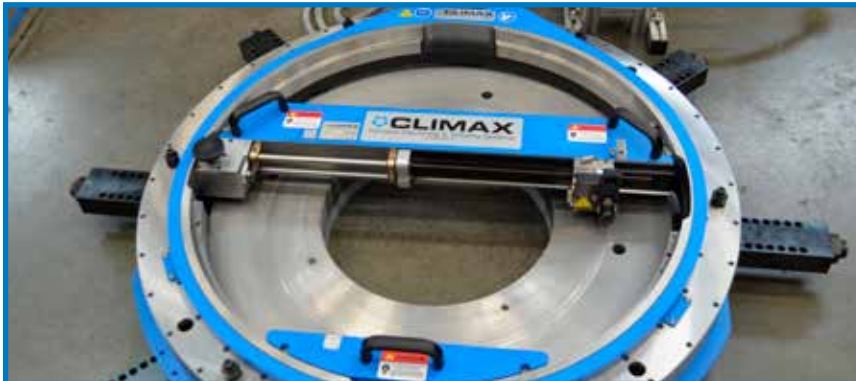

Industry-Changing Safety

- Feed control on the outside of the machine - no more reaching in!
- E-stop for quick stops & controlled re-starts
- Low pressure drop-out prevent unintended re-starts after loss of supplied air pressure
- CE Certified

Flexible and Versatile

- 1 machine for 7 flange types, no attachments needed
 - Flat face
 - Raised face
 - Ring type joints (RTJ)
 - Tongue & groove
 - Lens ring
 - Grayloc (hub profile)
 - Compact flanges
- Select from 3 models sized to machine flanges up to 12.5, 24.5

or 36.5 inches (317.5, 622.3 or 927.1 mm) in diameter

- Automatic & variable feed come standard on both radial and axial feeds for up to 30% time savings!
 - ... no reaching in means higher RPM machining
 - ... adjust feed rate while machining - no need to stop, change direction, or replace parts
 - ... start & stop feed while machining to machine to a shoulder
 - ... easy machining of various types of materials
 - ... a better surface finish
- Tool head and tool bit rotate independently, to any angle
- Tool head presets at 0°, 23°, and -23°

High Quality, Robust Design

- No broken shear pin in an event of a crash - just reset, and keep working
- Robust chucking mechanism and unique bearing design provide superior rigidity and machining performance
- Smooth-running rotational drive produces a high quality finish



SPECIFICATIONS

	FF1200 OD Mount Flange Facer	FF2400 OD Mount Flange Facer	FF3600 OD Mount Flange Facer
Machine Performance Ranges			
Mounting range	2 - 14.1 inches (50.8 - 358.1 mm)	8 - 26 inches (203.2 - 660.4 mm)	20 - 38 inches (508 - 965.2 mm)
Facing diameter range	0 - 12.5 inches (0 - 317.5 mm)	0 - 24.5 inches (0 - 622.3 mm)	0 - 36.5 inches (0 - 927.1 mm)
Radial tool slide travel	4.5 inches (114.3 mm)	16.5 inches (419.1 mm)	16.5 inches (419.1 mm)
Radial tool slide angle	max 1.5°	max 1.5°	max 1.5°
Axial tool head travel	2 inches (50.8 mm)	2 inches (50.8 mm)	2 inches (50.8 mm)
Feed rate	0 - 0.035 inches/rev. (0 - 0.889 mm/rev)	0 - 0.035 inches/rev. (0 - 0.889 mm/rev)	0 - 0.035 inches/rev. (0 - 0.889 mm/rev)
Rotational Drive System			
Drive type	Synchronous belt	Synchronous belt	Synchronous belt
Gear reduction	5.25 : 1	9.46:1	13.71:1
Turning arm speed range	10 - 60 RPM	5 - 30 RPM	4 - 25 RPM
Pneumatic power input requirements 1.1 Hp (0.8 kW)	90 psi @ 57 ft ³ /min (620 kPa @ 1.53 m ³ /min)	90 psi @ 74 ft ³ /min (600 kPa @ 2.1 m ³ /min)	90 psi @ 74 ft ³ /min (600 kPa @ 2.1 m ³ /min)
Measures	For machine dimensions, please refer to dimensional drawings.		
Machine weight	135 lbs (61.2 kg)	350 lbs (158.8 kg)	670 lbs (303.9 kg)
Shipping weight	Wood 260 lbs (117.9 kg) / Metal 300 lbs (136.1 kg)	Wood 510 lbs (231.3 kg) / Metal 550 lbs (249.5 kg)	Wood 930 lbs (421.8 kg) / Metal 1025 lbs (464.9kg)
Crate dimensions	Wood 30 x 34.5 x 16.5 inch (762 x 876 x 419 mm) / Metal 36 x 32 x 27 inches (914 x 813 x 686 mm)	Wood 47 x 37.5 x 16.5 inch (1194 x 953 x 419 mm) / Metal 41.5 x 38 x 25 inches (1054 x 965 x 635 mm)	Wood 54 x 57.5 x 16.5 inch (1371.6 x 1460.5 x 419.1 mm) / Metal 51.6 x 52.8 x 25.6 inches (1310.6 x 1341.1 x 650.2 mm)

In-House Testing Performance Results

	FF1200		FF2400		FF3600	
	Test 1 Material removal	Test 2 Finish	Test 1 Material removal	Test 2 Finish	Test 1 Material removal	Test 2 Finish
Depth of cut	0.05 inches (1.3 mm)	0.005 inches (0.127 mm)	0.035 inches (0.889 mm)	0.005 inches (0.127 mm)		0.005 inches (0.127 mm)
RPM	44	27	25	30		20
Feed	0.15 in/rev (3.8 mm/rev)	0.004 in/rev (0.102 mm/rev)	0.015 in/rev. (0.381 mm)	0.005 in/rev. (0.127 mm)		0.005 in/rev. (0.127 mm)
Dia. of cut	10 - 11 inches (254 - 279.4 mm)	10 - 11 inches (254 - 279.4 mm)	19 - 21 inches (482.6 - 533.4 mm)	19 - 21 inches (482.6 - 533.4 mm)		20 - 34 inches (508 - 863.6 mm)
Tool type	Insertable carbide	Insertable carbide	Insertable carbide	Insertable carbide		Insertable carbide
Finish	N/A	63 Ra	N/A	110 Ra	N/A	100 Ra
Metal removal rate	1.2 in ³ /min (19.7 cm ³ /min)	0.42 in ³ /min (6.9 cm ³ /min)	0.8 in ³ /min (13.1 cm ³ /min)	0.05 in ³ /min (0.82 cm ³ /min)		0.13 in ³ /min (2.1 cm ³ /min)
Flatness	N/A	0.002 inch (0.051 mm)	N/A	0.005 inch (0.127 mm)	N/A	0.004 inches (0.102 mm)

All dimensions should be considered reference. Contact your Climax Representative for precision dimensions. Specifications are subject to change without notice. There are no systems or components on this machine that are capable of producing hazardous EMC, UV or other radiation hazards. The machine does not use lasers nor does it create hazardous materials such as gasses or dust.

TOOL CONFIGURATIONS

To order your Mount Flange Facer, simply select the motor option for your machine.
Everything you need comes standard, no other attachments needed!

Option 1 With Standard Pneumatic Motor

FF1200 for 0 - 12.5 inch (0 - 317.5 mm) dia. flanges

with wood crate P/N 83012

with metal container P/N 80012

FF2400 for 0 - 24.5 inch (0 - 622.3 mm) dia. flanges

with wood crate P/N 83024

with metal container P/N 80024

FF3600 for 0 - 36.5 inch (0 - 927.1 mm) dia. flanges

with wood crate P/N 83036

with metal container P/N 80036

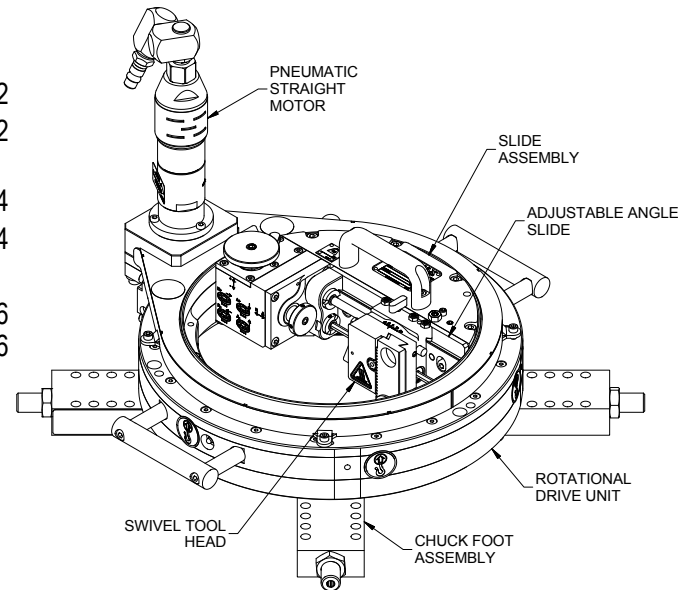

Option 2 With Right-Angle Pneumatic Motor

FF1200 for 0 - 12.5 inch (0 - 317.5 mm) dia. flanges

with wood crate P/N 84012

with metal container P/N 81012

FF2400 for 0 - 24.5 inch (0 - 622.3 mm) dia. flanges

with wood crate P/N 84024

with metal container P/N 81024

FF3600 for 0 - 36.5 inch (0 - 927.1 mm) dia. flanges

with wood crate P/N 84036

with metal container P/N 81036

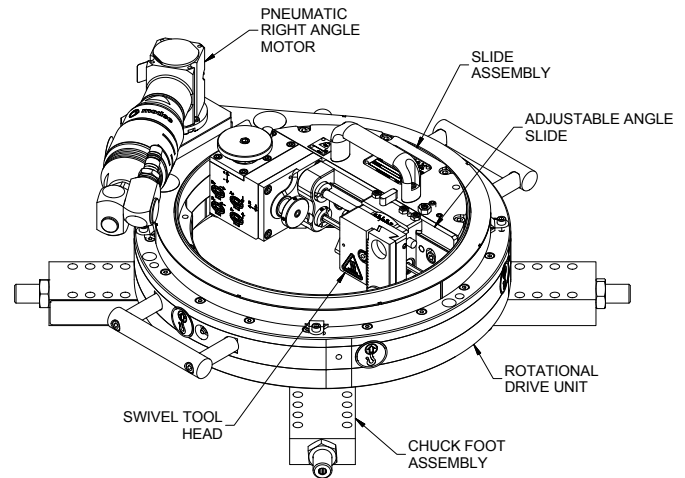

Accessories for use with the OD Mount Flange Facers

Carbide insert holder set, 1/2 square shank, 80 deg. diamond 3/8 inch P/N 56275

Vertical dial indicator, inch P/N 29138

Vertical dial indicator, metric P/N 23628

Indicator holder, articulated arm with mag base & fine adjust P/N 58369

Setup finger (1) - can be used to clamp to back side of flange P/N 80210

up to 1.75 inches (44.5 mm), or as replacement setup fingers purchased by the piece

Standard Pneumatic Motor for FF1200 P/N 80570

Standard Pneumatic Motor for FF2400 or FF3600 P/N 80632

Right-Angle Pneumatic Motor P/N 80618

FF1200 DIMENSIONS - STRAIGHT MOTOR

Dimensions in Inch (mm)

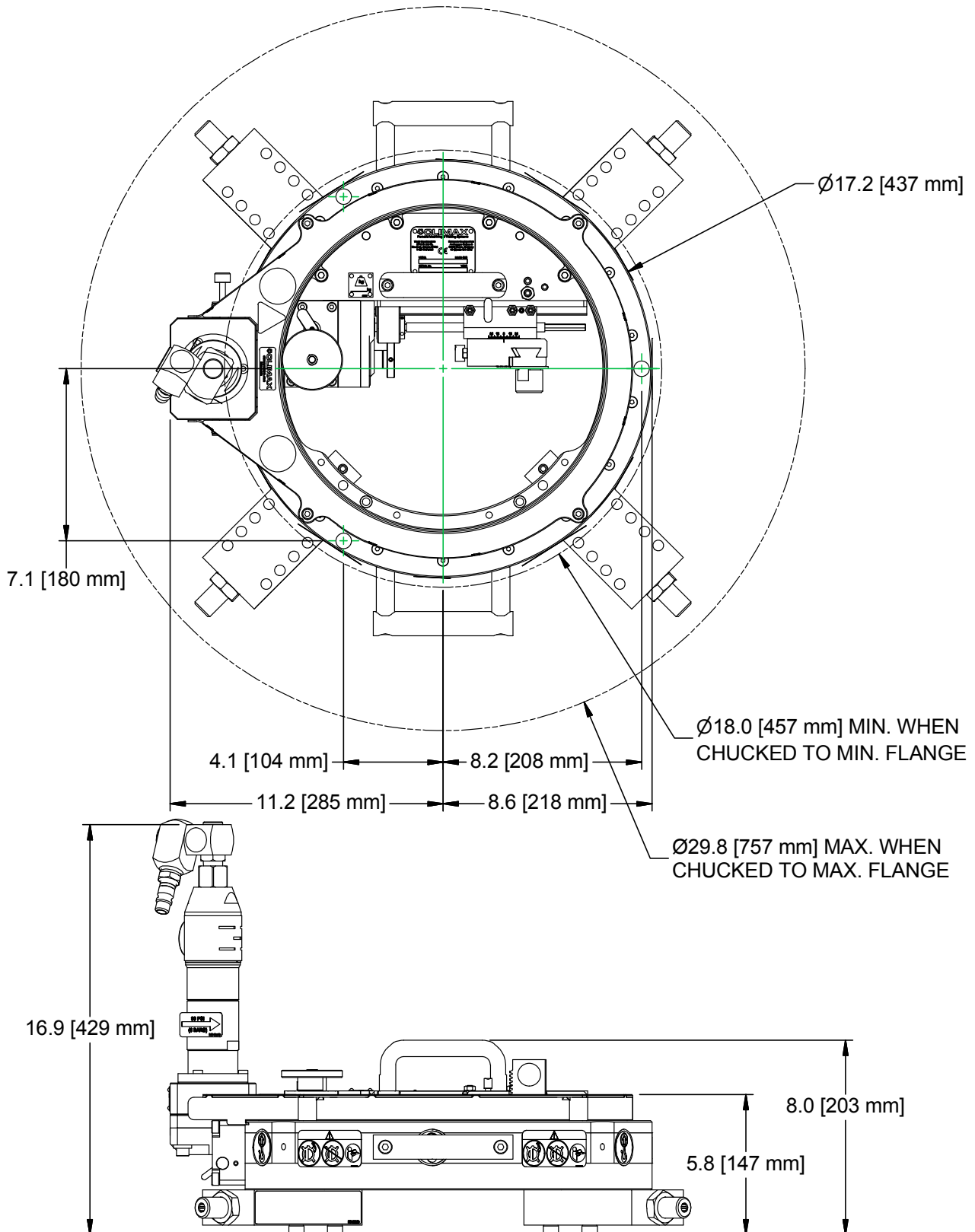

FF1200 DIMENSIONS - RIGHT ANGLE MOTOR

Dimensions in Inch (mm)

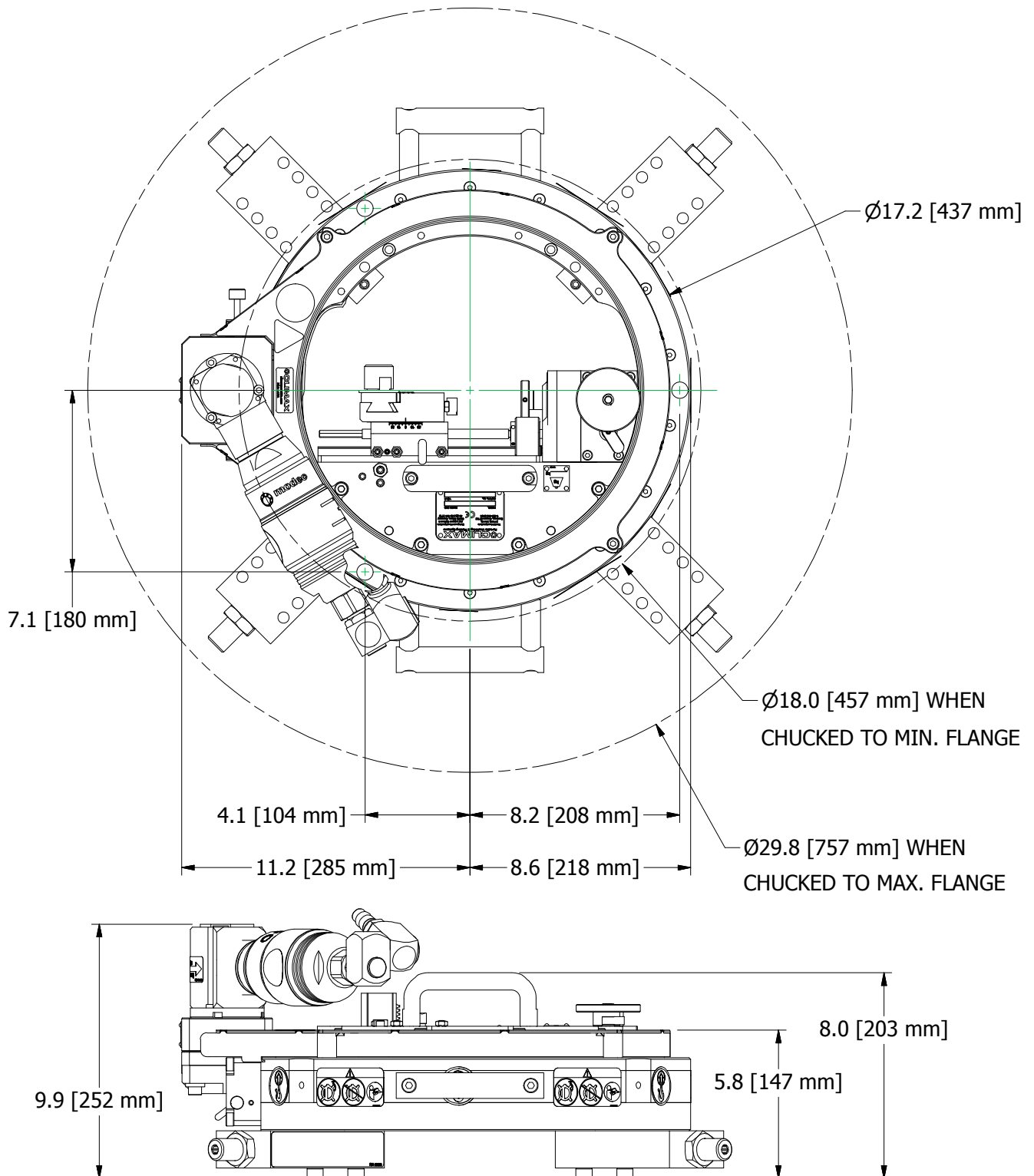

FF2400 DIMENSIONS - STRAIGHT MOTOR

Dimensions in Inch (mm)

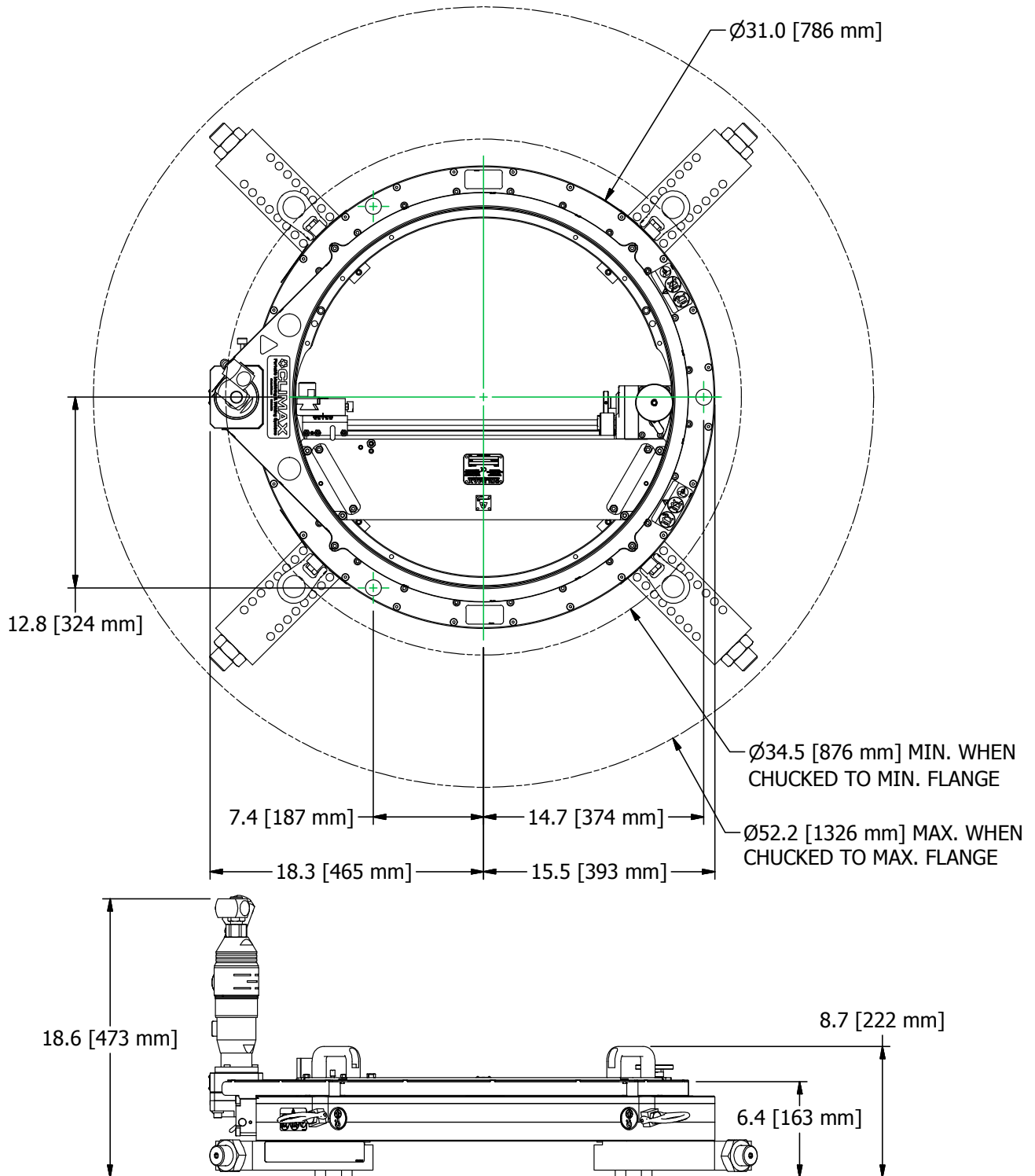

FF2400 DIMENSIONS - RIGHT ANGLE MOTOR

Dimensions in Inch (mm)

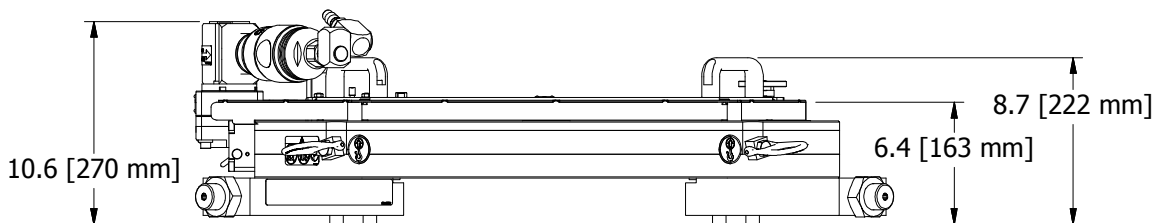
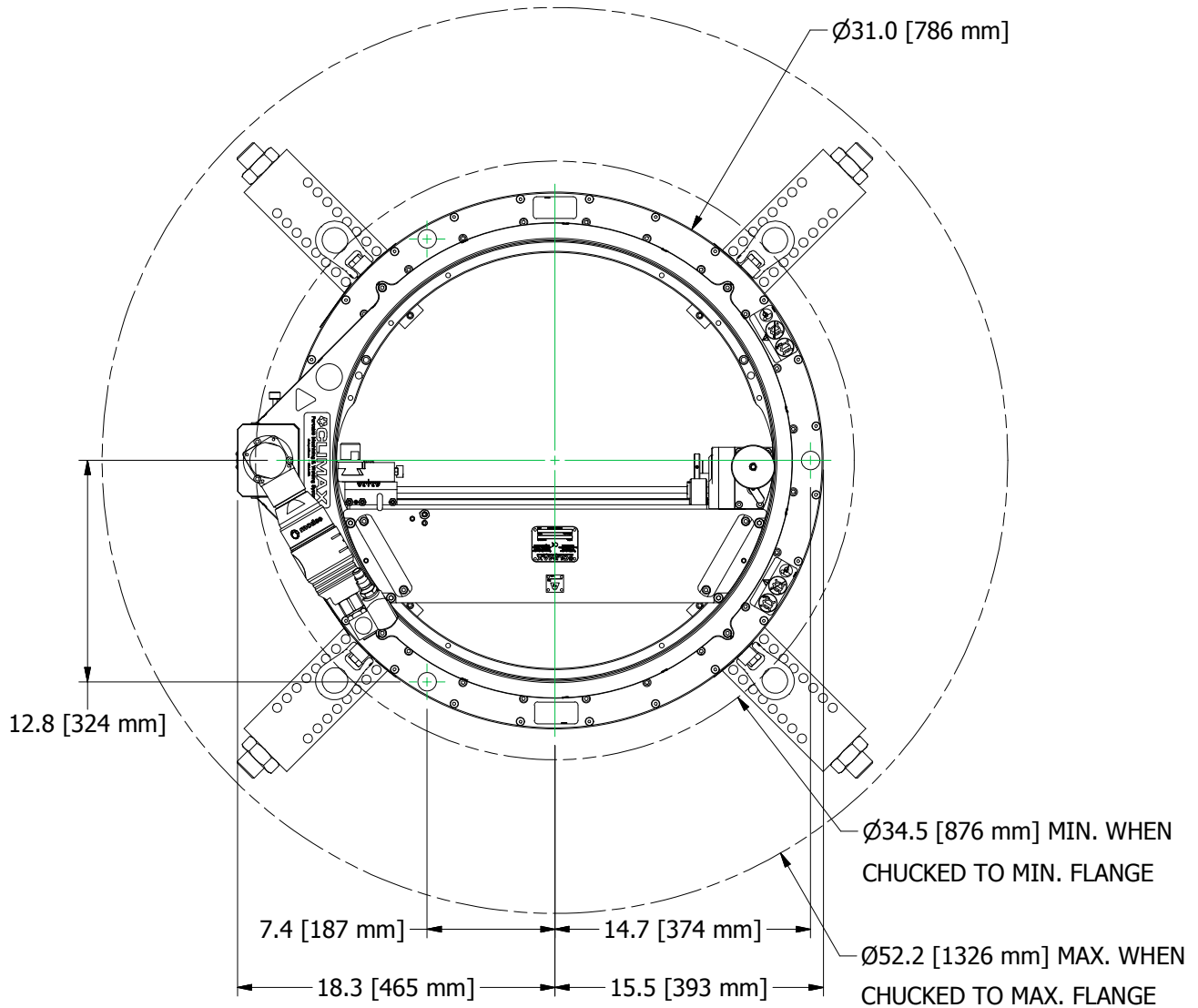

FF3600 DIMENSIONS - STRAIGHT MOTOR

Dimensions in Inch (mm)

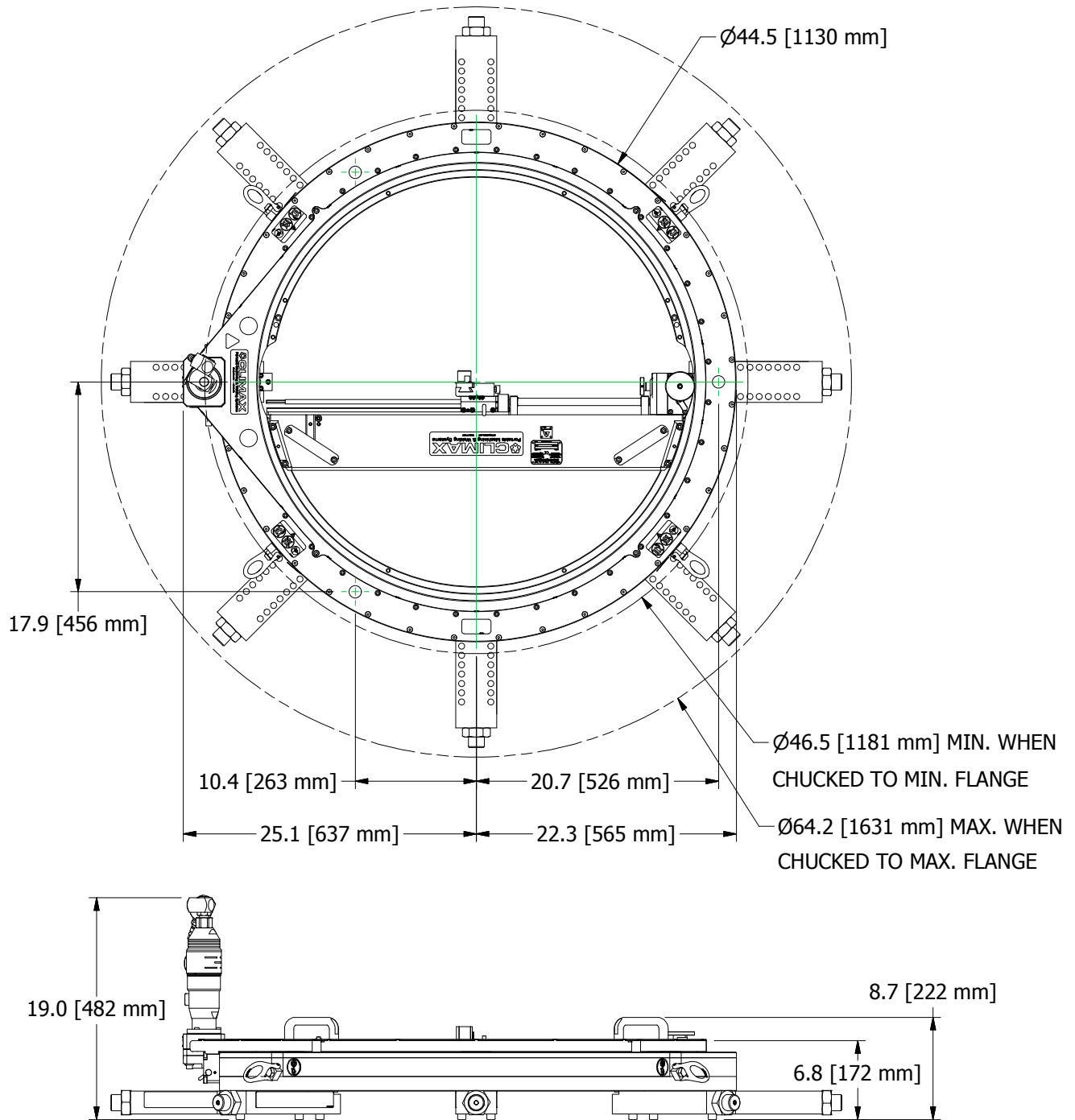

FF3600 DIMENSIONS - RIGHT ANGLE MOTOR

Dimensions in Inch (mm)

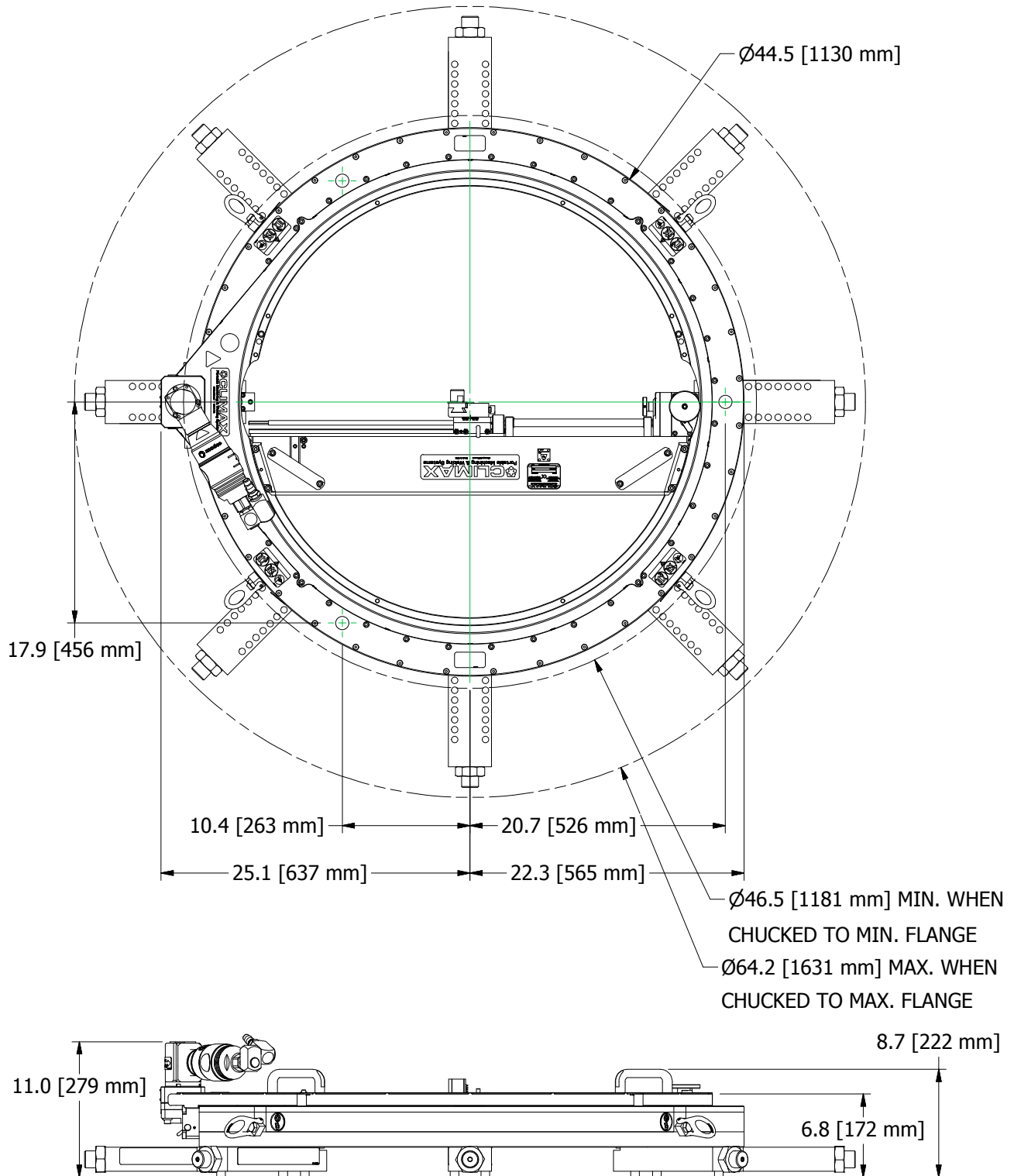

SETUP AND OPERATION

A Fast 6-Step Process

Setup is quick and easy. An experienced operator can usually mount the machine to a flange, center and level it, and start cutting in about 30 minutes.

1 Determine the chucking range. Use the chart on the side of each chucking foot to determine the correct chucking range for the workpiece.

	RANGE	1
MAX	inch	4.50
	mm	114
MIN	inch	2.00
	mm	51

4 Center and level the machine



2 Attach chucking feet to the machine. Use the holes in the chucking feet that correspond to the selected chucking range.



5 Install the slide assembly



3 Mount the machine to the workpiece. Tighten the chucking feet in small increments to secure the machine in place.



6 Install the cutting tool. Install the tool, then set the cutting angle.



* Images shown are of the FF1200 OD Mount Flange Facer

CLIMAX Training Facilities

CLIMAX has been teaching the fundamentals and finer points of portable machine tool operation for more than 50 years.

Whether it's a regularly scheduled course at one of our seven Global Training Centers or a custom curriculum conducted with your team, at your facility, your technicians will benefit from courses developed by the most experienced and respected professionals in the business.

Regularly scheduled courses in basic and advanced tool operation are available. A vast majority of every program is devoted to hands-on activities, skills development, and OEM Certification covering the following subject matters: operator safety, tool component review, setup and mounting, standard and advanced operational techniques, overview of cutting tools and recommended usage, and maintenance procedures.



Training is available at the following seven Global Training Centers:

- Portland, Oregon
- Houston, Texas
- Gonzales, Louisiana
- Wadsworth, Ohio
- Manchester, United Kingdom
- Düren, Germany
- Dubai, United Arab Emirates

Call us today to schedule training for your team!



CLIMAX GLOBAL LOCATIONS

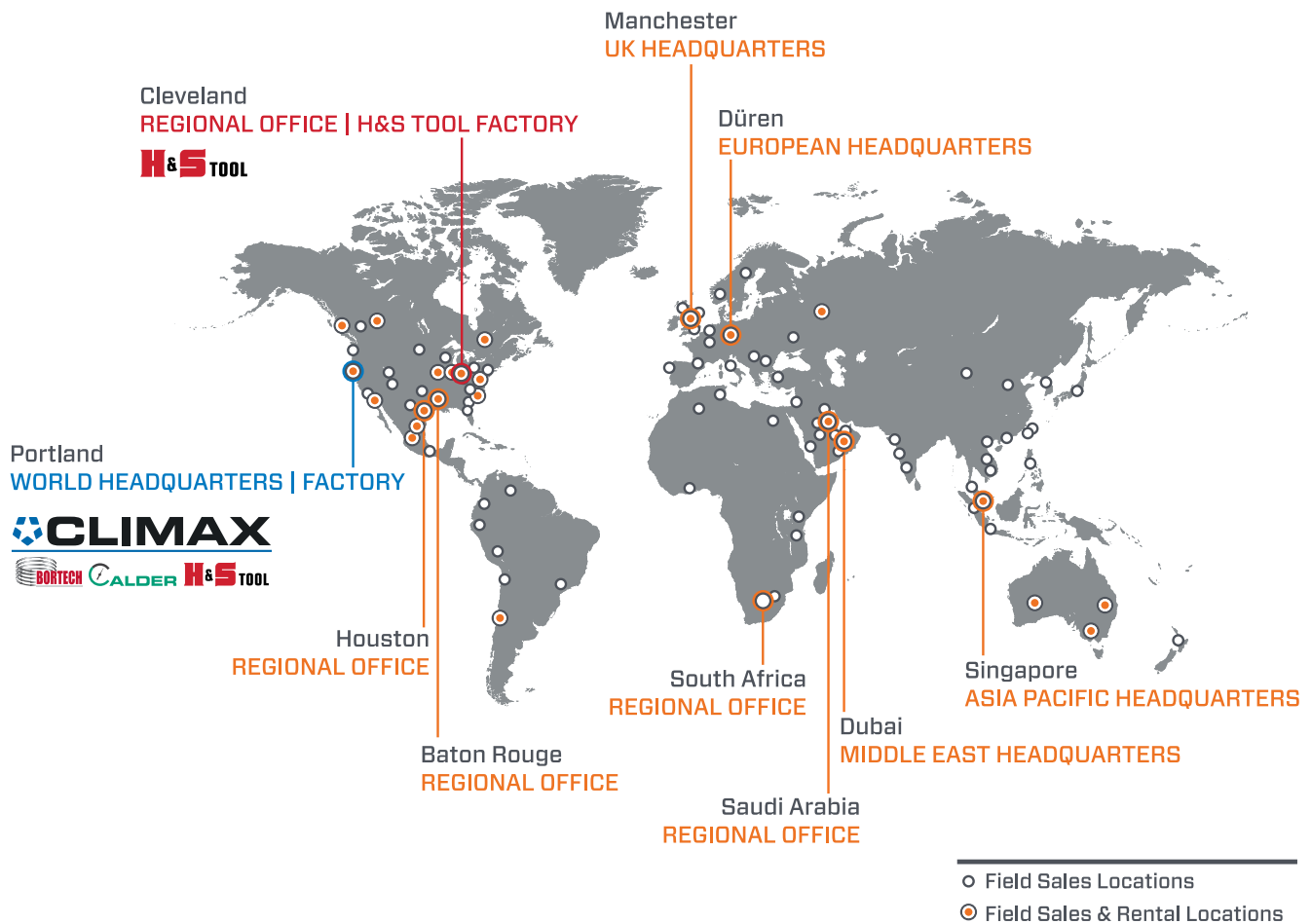

Call CLIMAX for:

RENTALS

With 20+ worldwide rental depot locations, you are never far away from a CLIMAX tool.

ON-SITE TRAINING

If you need training or on-site consultation, we're famous for it!

CUSTOM PROJECTS

Custom turn-key system design services from the most experienced engineers and portable machining and welding experts!

Connect with us:    

World Headquarters

CLIMAX | BORTECH | CALDER Factory
Address: 2712 E. 2nd St, Newberg, Oregon 97132
Tel: +1 503 538 2185
Fax: +1 503 538 7600
Email: info@cpmt.com

Regional Office - Cleveland

H&S TOOL Factory
Address: 715 Weber Dr., Wadsworth, Ohio 44281
Tel: +1 330 336 4550
Email: info@hstool.com

Asia Pacific

Address: 308 Tanglin Rd #02-01, Singapore 247974
Tel: +65 6801 0662
Fax: +65 6801 0699
Email: ClimaxAsia@cpmt.com

European

Address: Am Langen Graben 8, 52353 Düren, Germany
Tel: (+49) (0) 2421 9177 0
Fax: (+49) (0) 2421 9177 29
Email: ClimaxEurope@cpmt.com

Middle East

Address: Warehouse #5, Plot: 369 272, Um Sequim Road, Dubai, UAE
Tel: +971 4 321 0328
Email: ClimaxUAE@cpmt.com

United Kingdom

Address: Unit 7 Castlehill Industrial Estate, Bredbury Industrial Park, Horsfield Way, Stockport SK6 2SU
Tel: +44 (0) 161 406 1720
Email: ClimaxUK@cpmt.com

Copyright © 2018 CLIMAX Portable Machining & Welding Systems. All Rights Reserved. CLIMAX has taken reasonable measures to ensure the accuracy of the information contained in this document. However, CLIMAX makes no warranties or representations with respect to the information contained herein; and CLIMAX shall not be held liable for damages resulting from any errors or omissions herein, or from the use of the information contained in this document.

