

Designed to cut extra-wide keyways, stress relief pockets, motor mounts slots, and more.

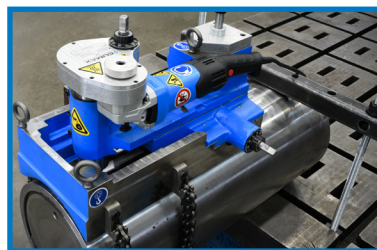
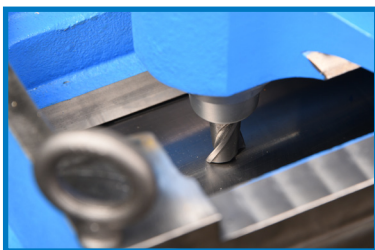
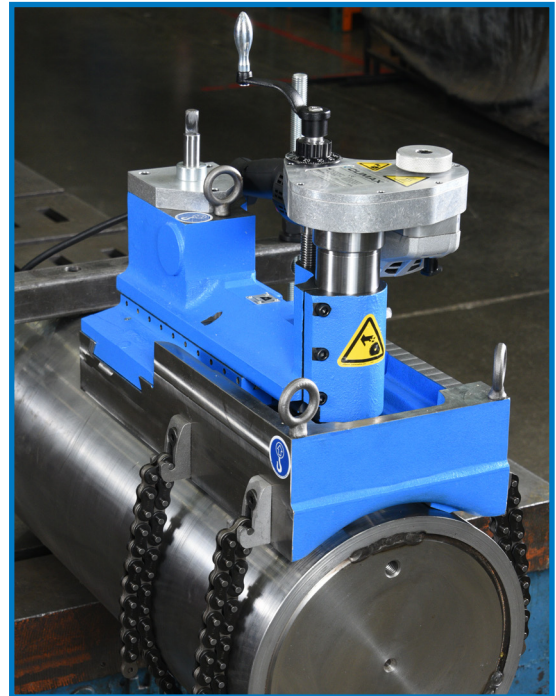
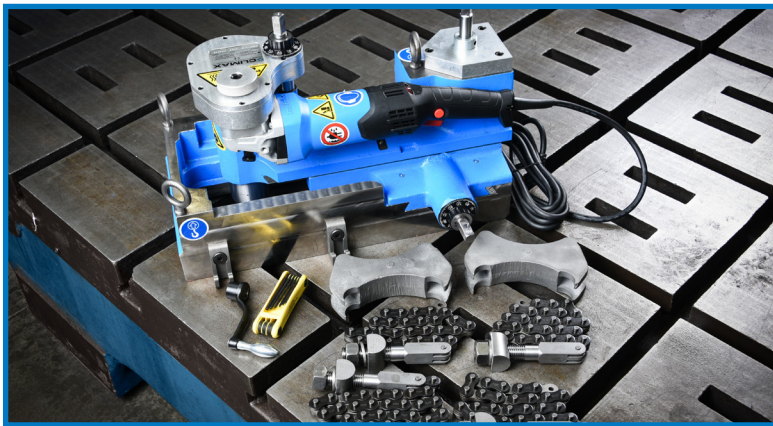

The KM4000 Portable Key Mill is a compact, rugged, and fully CE-compliant milling machine, designed for cutting extra-wide keyways, stress relief pockets, motor mount slots, and more.

COMPACT & POWERFUL

Compact design requires only 8.5 inches (215.9 mm) of shaft for clamping or 10.5 inches (266.7 mm) of shaft for clamping from an obstruction. It mounts on shafts ranging from 4 to 24 inches (101.6 to 609.6 mm) in diameter and can be positioned anywhere along the shaft, offering ultimate flexibility.

Universal-type motor and triple gear reduction provide ample torque for efficient cutting.

Anti-friction bearings are used throughout for enhanced performance and longevity.

Precisely cuts new keyways up to 3.25 inches (82.6 mm) wide and 7.88 inches (200.2 mm) long in one setup.

Two-inch (50.8 mm) lateral travel allows cutting wide pockets or slots with a single end mill.

EFFICIENT OPERATIONS WITH HIGH-QUALITY COMPONENTS

Self-centering and self-aligning contoured-base ensures your keyway is perfectly centered on the shaft.

Dovetail ways are machined for smooth movement in both longitudinal and transverse directions, ensuring precision.

Precision Acme thread leadscrew fitted with roller thrust bearings ensures smooth operation and accuracy.

Zeroing-type adjustable dial for precise control of cutter depth.

Permanently sealed lubrication allows operation at any angle, ensuring versatility.

Rapid longitudinal travel can be achieved with a drill motor for quick setups.

Motor is equipped with a soft start function and maintains speed as load increases, ensuring consistent performance.

SAFETY

CE and CSA certified and available worldwide! All KM4000 Key Mills are available for sale worldwide, including in the European Union and other locations where CE or CSA certification is required.

TECHNICAL DATA

- 0.75 inches (19.05 mm) is the standard spindle size for inch-machines
- 20 mm (0.79 inches) is the standard spindle size for metric machines.
- For information on different machine variations, please contact your CLIMAX Sales Representative.

SPECIFICATIONS

	Inch	Metric
Machine Performance Ranges		
Slide travel, longitudinal	7.88 in	200.2 mm
Slide travel, transversal	2.0 in	50.8 mm
Vertical travel max.	3.0 in.	76.2 mm
No load variable spindle speed minimum maximum		180 rpm 530 rpm
Spindle hole diameter INCH METRIC	0.75 in. 0.79 in.	19.1 mm 20 mm
Maximum end mill diameter	1.25 in.	31.75 mm
Maximum shaft diameter: standard bar clamp with optional chain clamp	18 in. 24 in.	457.2 mm 609.6 mm
Minimum shaft diameter: standard bar clamp with optional shim kit	8 in. 4 in.	203.2 mm 101.6 mm
Minimum clamping space required: on stub shaft obstructed shaft (NOTE: The KM4000 can cut keyways within 2.2 in. (55.88 mm) of the obstruction)	8 in. 10.5 in.	203.2 mm 266.7 mm
One end mill included	Ø 0.75 in.	Ø 19.1 mm
Power Options		
Electric	120V or 230V, 50-60Hz	
Pneumatic (upon request)	1.5 HP	1.12 kW
Hydraulic (upon request)	0.79 in. ³ - 4.0 HP	12.9 cm ³ - 3.0 kW
	1.93 in. ³ - 3.3 HP	31.6 cm ³ - 2.5 kW
Measurements		
Overall length	18.5 in.	469.9 mm
Overall width	14.0 in.	355.6 mm
Overall height	13.25 in.	336.6 mm
Base size	9.0 x 18.5 in.	228.6 x 469.9 mm
Operating weight	195 lbs	89 kg
Shipping weight	250 lbs	114 kg
Shipping dimensions	24 x 24 x 19 in.	610 x 610 x 483 mm
Machining Ability Example		
Material	C1018 steel	
Metal removal rate for hydraulic power	1 in. ³ /minute	16.4 cm ³ /min
Metal removal rate for electrical power	0.4 in. ³ /minute	6.5 cm ³ /min
Keyway dimensions	1.0 x 0.5 x 8 in.	25.4 x 12.7 x 203.2 mm
Cutting Time	3 minutes and 10 seconds *	

The KM4000 is widely used by these industries:

- Construction
- Bridge building & repair
- Power Generation
- Ship building
- Pulp and paper
- Steel and aluminum

Typical applications:

- Keyways on tapered shafts
- Milling stress relief pockets on bridge decks
- Cut motor mount slots in plate or I-beams
- Cut inspection windows in vessels
- Cut keyways on motors

Mounting applications include:

- **Mounting on end of shaft:** Needs only 8.5 inches (215.9 mm) of shaft for clamping, or only 10.5 inches (266.7 mm) of shaft for clamping from an obstruction. (NOTE: The KM4000 can cut keyways within 2.2 inches (55.88 mm) of the obstruction)
- **Mount in the middle:** The machine can be leveled for cutting long keyways.
- **Tapered shafts:** Mounting on tapered shafts requires shimming

Set-up and Operation

Insert the end mill in the spindle of the KM4000 Portable Key Mill, and clamp it on that shaft - it's that simple. On a straight shaft, an experienced operator can mount the machine and be ready to cut a new keyway in less than 15 minutes! Shimming to tapered shafts may take a little longer.

The 2.0 inch (50.8 mm) lateral travel of the KM4000 allows you to cut wide keyways or slots with a less expensive, smaller end mill. The calibrated cross slide is positioned with the hand crank.

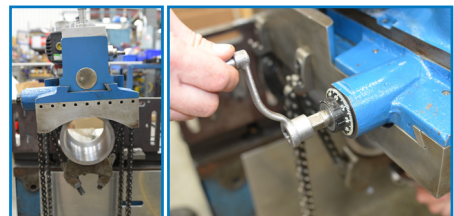

All dimensions should be considered reference. Contact your Climax Representative for precision dimensions. Specifications are subject to change without notice. There are no systems or components on this machine that are capable of producing hazardous EMC, UV or other radiation hazards. The machine does not use lasers nor does it create hazardous materials such as gasses or dust.

DIMENSIONS, TOOL CONFIGURATIONS

Dimensions in inch (mm)

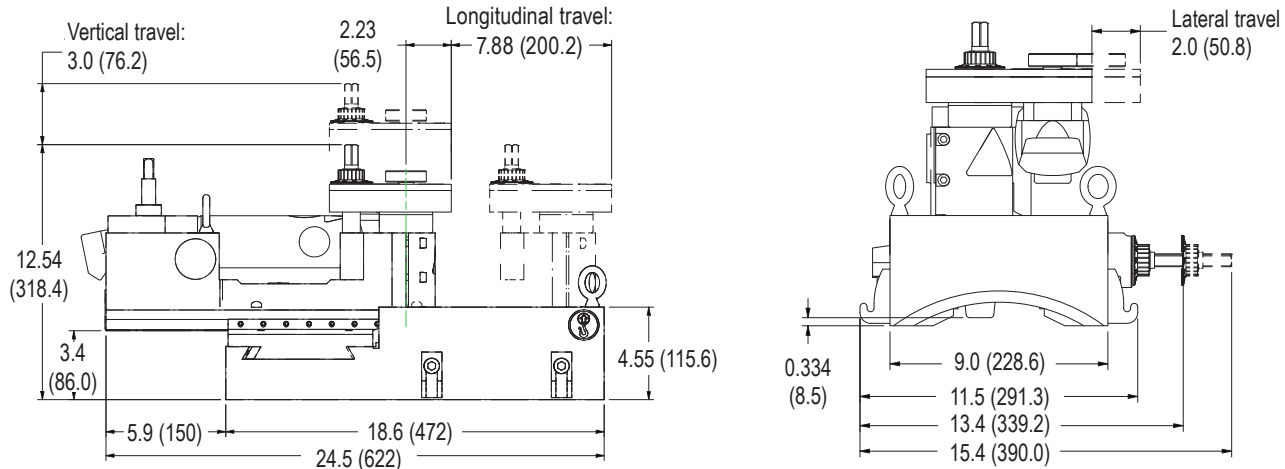

TOOL CONFIGURATIONS

To order your KM4000 Key Mill, simply select your Key Mill and contact your CLIMAX sales representative.

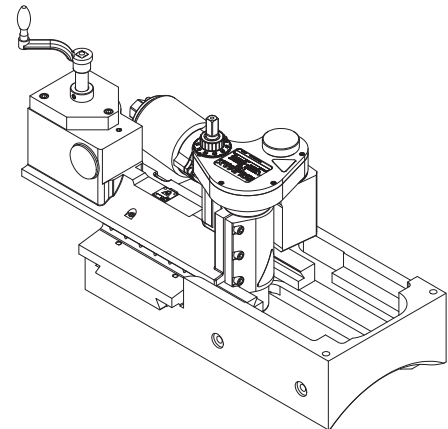

The KM4000 Key Mills come standard with a motor, chain clamp, end mill, hex wrenches, crank, operator manual, and wood crate. **All KM4000 Key Mills are CE-Compliant.**

Part No.	Inch/Metric	Spindle	Motor	Approx. Weight
Electric motor, 1.0 Hp (0.75 kW) with speed controller				
103907	Inch	3/4 inch	120 V	240 lb (110 kg)
103908	Metric	20 mm	120 V	
103909	Inch	3/4 inch	230 V	
103910	Metric	20 mm	230 V	
Pneumatic, 1.2 Hp (0.9 kW) Motor requires 40 ft³/min (1 m³/min) at 90 psi (620 kPa)				
10507	Inch	3/4 inch	NA	245 lb
10510	Metric	20 mm	NA	(112 kg)
Hydraulic, 4.0 Hp (2.98 kW) available upon request				
16297	Inch	3/4 inch	274 rpm*	233 lb (106 kg)
16314	Inch	3/4 inch	430 rpm*	
16315	Inch	3/4 inch	664 rpm*	
* rpm at the spindle @ 6 gal/min (22.3 liter/min)				

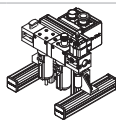
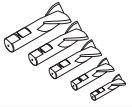
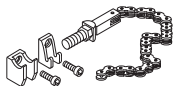
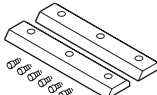

NOTE: Drawings are for reference only, are not to scale, and may not represent actual product.

ACCESSORIES

<p>Pneumatic conditioning unit - Required to protect air motor warranty. Includes: lubricator, filter, stand, and air line. Sold only as a unit. Weight 11 lbs (5 kg)</p> 	101920	<p>End Mill Sets</p> <p>SAE and metric 2-flute end mills are available. Short flutes for maximum rig.</p> 
<p>Chain clamp assembly - 20 in. (508 mm) chains for use in addition to standard chain clamp assembly. Used to attach key mill to shafts 18 - 24 in. (457.2 - 609.6 mm) in diameter. Weight 8.6 lbs (3.9 kg)</p> 	10493	<p>End mill set, inch - Seven end mills from 1/4 - 1 in. in 1/8 in. increments, plus collet. 10385</p>
<p>Shim kit Shims fit inside base to enable the key mill to be mounted on shafts as small as 4.0 in. (101.6 mm) in diameter. Weight: 3.4 lbs (1.6 kg).</p> 	11851	<p>End mill set, inch - Eight end mills from 3/16 - 1 in. in 1/16 inch increments, and seven end mills from 1/4 - 1 in. in 1/8 in. increment, plus 3/8 in. ID collet for end mills 7/16 in. and smaller. 10386</p>
<p>Tool kit Hand crank and hex wrenches necessary to operate the key mill. Weight 0.5 lbs (0.3 kg)</p> 	13737	<p>End mill set, metric - Five end mills: 8 mm, 10 mm, 12 mm, 16 mm, and 18 mm, plus two collets, one with 16 mm OD with 10 mm ID, the other with 16 mm OD and 12 mm ID. 10387</p> <p>End mill set, metric - Eight end mills: 5 mm, 6 mm, 8 mm, 10 mm, 12 mm, 14 mm, 16 mm, 18 mm, plus three collets. 22387</p>

OEM OPERATIONAL TRAINING

Backed by 60 Years of Experience

CLIMAX pioneered the concept of portable machine tools in 1964. Since that time, CLIMAX has grown to become the world's largest provider of innovative on-site machining solutions.

Professional, Experienced Instructors

All training programs are taught by experienced OEM CLIMAX trainers. Your instructor will provide valuable information on operator safety, tool set-up, mounting, and operation that will help you complete your on-site machining tasks quickly and to the highest quality standards. **Part number 00042**

Sign up today for training at one of our eight Global CLIMAX training centers.

- Portland, Oregon
- Houston, Texas
- Baton Rouge, Louisiana
- Cleveland, Ohio
- Manchester, United Kingdom
- Düren, Germany
- Dubai, United Arab Emirates
- Dammam, Saudi Arabia



Call CLIMAX for:

RENTALS

On selected models. With 20+ world-wide rental depot locations, you are never far away from CLIMAX.

OEM TRAINING

If you need training or on-site consultation, we're famous for it!

SPARES, REPAIR & MAINTENANCE

Call us for anything you need to keep your system running in top condition.

CUSTOM PROJECTS

Custom turn-key system design services from the most experienced engineers in the business!

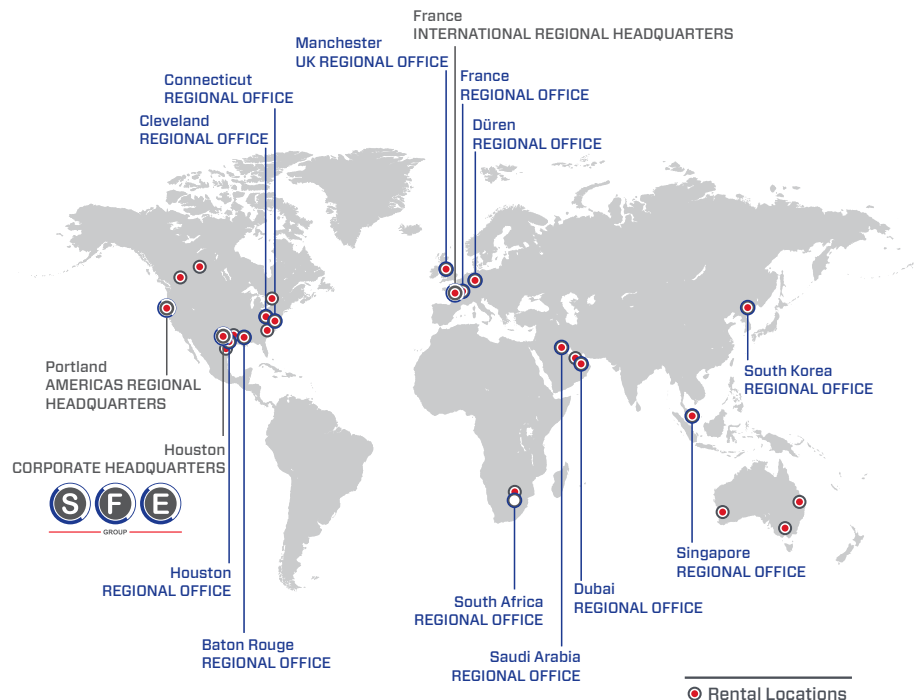

Follow us on:   

CORPORATE HEADQUARTERS

Address: 4433 South Drive, Houston, Texas 77053, USA

Tel: +1 (713) 747 8502

Email: sales@sfe-brands.com

AMERICAS HEADQUARTERS

Address: 2712 E. 2nd St, Newberg, Oregon 97132, USA

Tel: +1 503 538 2185

Email: info@sfe-brands.com

INTERNATIONAL HEADQUARTERS

Address: 330B Route de Portes Les Valence, ZI les Bosses 26800 Etoile-sur-Rhône, France

Tel: + 33 (0) 475 575 070

Email: sales-int@sfe-brands.com

Copyright © 2024 S.F.E. GROUP All Rights Reserved. S.F.E. GROUP has taken reasonable measures to ensure the accuracy of the information contained in this document. However, S.F.E. GROUP makes no warranties or representations with respect to the information contained herein; and S.F.E. GROUP shall not be held liable for damages resulting from any errors or omissions herein, or from the use of the information contained in this document.

 **CLIMAX**
Portable Machining & Welding Systems
AN SFE GROUP BRAND