

Easy OD-mount Flange Facer For Repairs of Flanges 2 to 12 inches (50.8 to 304.8 mm) in Diameter.

The Model FF1000 Portable Flange Facer comes complete with all the components you need to get started. It consists of a mounting bell, a power module, and a flange facing module. A 115V power vertical feed module is offered as an option. Individual components and accessories are available for replacement or when required for some applications. See the Components page for the package that's right for you.

The Climax FF1000 Flange Facer

- Sets up and operates easily.
- Cuts O-ring grooves.
- Uses standard $\frac{3}{8}$ -inch, square tool bits.
- Includes 1.22 hp (0.91 kW) pneumatic motor.

Two Mounting Bell Sizes

- 8 inch module mounts on flanges 4 to 8 inches (101.6-203.2 mm) in diameter.
- 12 inch module mounts on flanges 8 to 12 inches (203.2 to 304.8 mm) in diameter.

Two Power Modules

- Use with either mounting bell. Variable radial feed rate. Manual depth adjustment / longitudinal feed.
- 100 rpm with a 15:1 gear reduction, 1-inch (25.4 mm) stroke, 105 ft•lb (142.7 N•m) of torque.
- 200 rpm with a 7.5:1 gear reduction, 1-inch (25.4 mm) stroke, 52.5 ft•lb (71.4 N•m) of torque

Optional Power Feed Module

- Some applications require a remotely operated power axial feed. This 115V unit attaches to the power module. Axial feed rates are available from 0.04 to 1.6 inches/minute (1.0 to 40.6 mm/min.).



Two Facing Heads:

- 8 inch module faces 0 to 8 inches (0 to 203.2 mm) in diameter.
- 12 inch module faces 0 to 12 inches (0 to 304.8 mm) in diameter.

Optional Small Flange Adapter Plate

- Attaches to the bottom of the 8 inch (203.2 mm) diameter mounting bell to allow re-facing flanges from 2 to 4 inches (50.8 to 101.6 mm) in diameter.
- Unit comes complete with setup fingers to accommodate smaller diameter flanges.

Quick and Easy Setup

- An experienced operator can set up the FF1000 Portable Flange Facer in less than half an hour.
- Once you are familiar with the machine, re-facing 2 to 3 standard flanges per hour is typical (depending on the size and type of flanges, access and general working conditions).

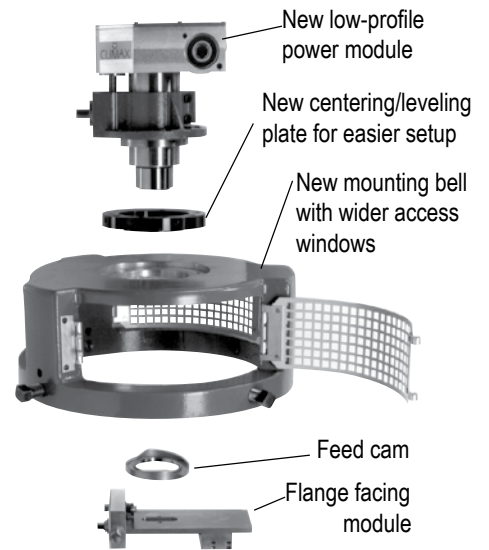

The new, wider access windows make adjustments to the facing head gearbox easier than ever.

OPERATIONAL DIMENSIONS

Specifications in inches (mm)

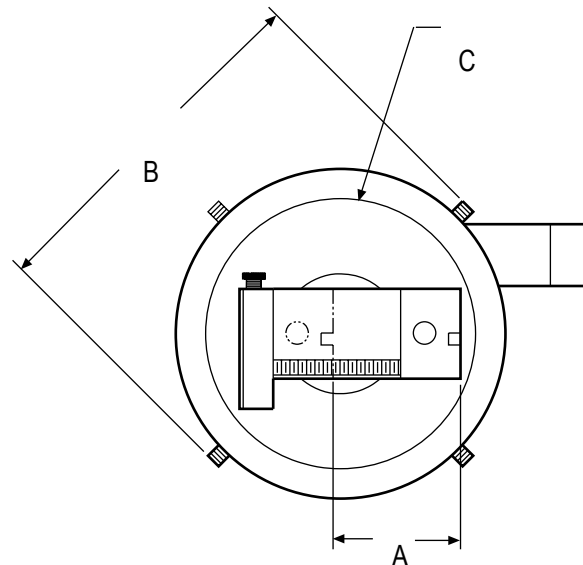
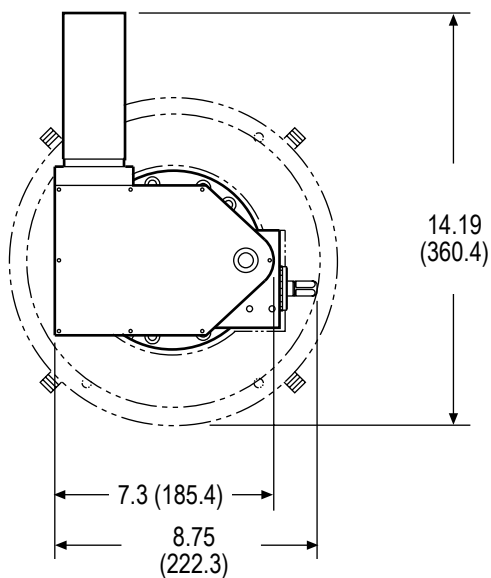
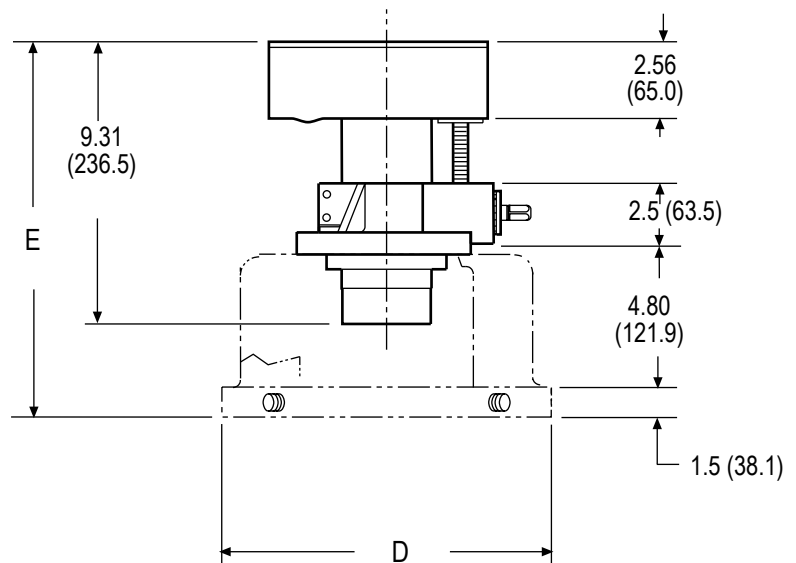
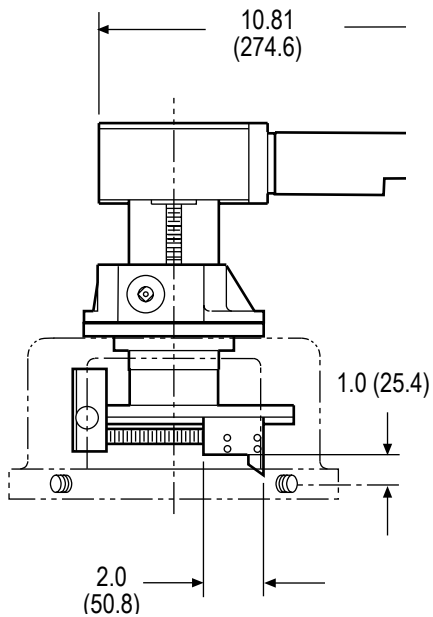

	A	B		C	D	E	
		min	max			min	max
30717 200 rpm power module	---	---	---	---	---	11.86 (301.2)	13.31 (338.1)
31679 100 rpm power module	---	---	---	---	---	11.86 (301.2)	13.31 (338.1)
30719 8" mounting bell	4.1 (104.1)	12.0 (304.8)	14.25 (361.9)	9.0 (228.6)	11.75 (298.5)	---	---
30990 12" mounting bell	6.1 (154.9)	16.0 (406.4)	18.0 (457.2)	13.0 (330.2)	15.75 (400.0)	---	---

Shipping dimensions:
19.75 x 30.5 x 22.5

Machine net weight: 74 (33.6 kg)
(Typical machine including power module 30717 and 8" flange facing module 30718.)

All dimensions should be considered reference. Contact your Climax Representative for precision dimensions. Specifications are subject to change without notice. There are no systems or components on this machine that are capable of producing hazardous EMC, UV or other radiation hazards. The machine does not use lasers nor does it create hazardous materials such as gasses or dust.

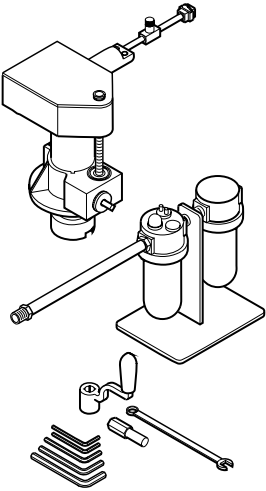
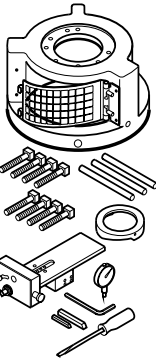
No.	Description	No.	Description
	<p>35178 FF1000 flange facer with 8 inch (203.2 mm) bell 100 rpm includes spindle, quill, alignment plate, quill clamp, drive gear box, 1.22 hp (0.91 kW) air motor, air conditioning unit, 8 inch (203.2 mm) OD mounting bell (p/n 30718, also sold separately) with setup hardware, facing head assembly, dial indicator, ¼ inch and ⅜ inch HSS tool bits, tool kit, and wooden storage crate. Air motor requires: 90 psi (620 kPa) at 30 ft³/min (.85 m³/min) at maximum power. Vertical feed is manual. Spindle free speed 96 rpm max. Spindle provides 42.5 rpm and 105 ft-lb (142.7 N•m) torque at rated hp. 1 inch (25.4 mm) travel.</p>	<p>30996 FF1000 flange facing module, 12 inch (304.8 mm) diameter. Mounts onto flanges 8 to 12 inches (203.2 to 304.8 mm) in diameter. Faces 0 to 12 inch (0 to 304.8 mm) diameters. Radial feed is manual or automatic. Radial feed speed is variable, up to 0.035 inches/rev. (0.89 mm/rev.) Net weight 29 lbs (13.2 kg).</p>	
	<p>35179 FF1000 flange facer with 12 inch (304.8 mm) bell 100 rpm. Same as p/n 35178 above but with 12 inch (304.8 mm) bell (p/n 30996, also sold separately).</p>	<p>Replacement tool bits One of each tool listed below is included with each flange facing module.</p>	
	<p>35180 FF1000 flange facer with 8 inch (203.2 mm) bell 200 rpm. Same as p/n 35178 above except spindle free speed is 192 rpm max. Spindle provides 98.4 rpm and 52.5 ft-lb (71.4 N•m) torque at rated hp. 1 inch (25.4 mm) travel.</p>	<p>31863 Tool bit, roughing ⅜ inch square x 1.3 inches long</p> <p>31854 Tool bit, finishing ⅜ inch square x 1.3 inches long</p>	
	<p>35181 FF1000 flange facer with 12 inch (304.8 mm) bell 200 rpm. Same as p/n 35180 above but with 12 inch (304.8 mm) bell.</p>	<p>11863 115V Power vertical feed module Module mounts securely to the quill support shaft to automatically feed the machine axially. Feed rate is adjustable from 0.04 to 1.6 inches (1.0 to 40.6 mm) per minute. Values are theoretical and may vary in actual use.</p>	
	<p>FF1000 Flange facing module includes OD mounting bell with setup hardware, facing head assembly, ¼ and ⅜ inch HSS tool bits.</p>	<p>10993 Tool kit Complete set of tools for the FF1000 Flange Facer. Tool kit is included with complete machine packages.</p>	
 <p>30718 FF1000 flange facing module, 8 inch (203.2 mm) diameter. Mounts onto flanges 4 to 8 inch (101.6 to 203.2 mm) in diameter. Faces 0 to 8 inch (0 to 203.2 mm) diameters. Radial feed is manual or automatic. Radial feed speed is variable, up to 0.035 inches/rev. (0.89 mm/rev.) Net weight 23 lbs (10.5 kg).</p>	<p>9091 Small flange adapter plate Attaches to bottom of 8 inch (203.2 mm) diameter mounting bell. Allows attachment of mounting bell to 2 to 4 inch (50.8 to 101.6 mm) diameter flanges. Net weight 11 lbs (5.0 kg).</p>		

NOTE: Drawings are for reference only, are not to scale, and may not represent actual product.

CLIMAX GLOBAL LEARNING CENTER

Climax has been teaching the fundamentals and fine points of portable machine tool operation for practically as long as we've been inventing and building the tools.

At the Global Learning Center situated in our corporate headquarters near Portland, Oregon, we provide training for machine tool operators on portable machine tool safety and machine setup and operation. Trainees also receive technical tips and tools to improve operational efficiencies, with the vast majority of every program devoted to hands-on activities and skill development.

The Climax instructional team includes specialists in shipbuilding, power generation, civil engineering, bridge re-building, petrochemical and other industries.

Whether it's a regularly scheduled course at the Global Learning Center, or custom curriculum conducted at your facility, your machinists will benefit from courses developed by some of the most respected authorities in the business.

Call us today to register for a regularly scheduled class, or talk to us about how we can customize a training program for your specialized application.



Call Climax for:

On-site Training

Need some refresher courses in setting up and operating your Climax machine tool?

Special Projects

Climax has been solving complicated on-site machining and welding problems for our customers since 1964.

Rentals

With 14 worldwide rental depot locations, you are never far away from a Climax portable machine tool.

Climax Global Locations

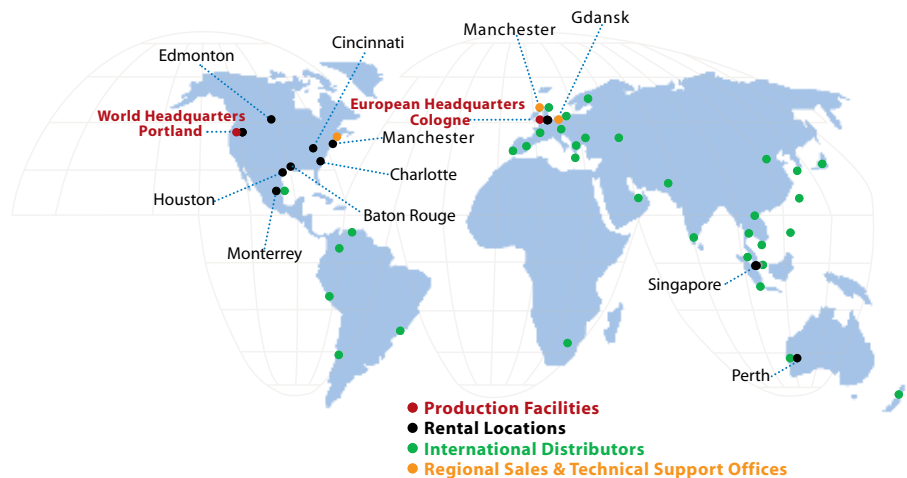

Connect with us:  

World Headquarters

2712 E. Second Street
Newberg, Oregon 97132 USA
Worldwide Telephone: 1.503.538.2185
N. America Toll-Free: 1.800.333.8311
Fax: 1.503.538.7600
Email: info@cpmt.com

European Headquarters

Am Langen Graben 8
52353 Düren, Germany
Telephone: (+49) (0) 2421.9177.0
Fax: (+49) (0) 2421.9177.29
Email: info@cpmt.de

Copyright © 2013 Climax Portable Machining & Welding Systems. All Rights Reserved. Climax has taken reasonable measures to ensure the accuracy of the information contained in this document. However, Climax makes no warranties or representations with respect to the information contained herein; and Climax shall not be held liable for damages resulting from any errors or omissions herein, or from the use of the information contained in this document.

 **CLIMAX**
Portable Machining & Welding Systems