

## Packing big boring capability into a compact, modular machine, maximizing efficiency and minimizing downtime.

### Powerful Yet Compact

- Take the power of a stationary machine to the job site to solve tough machining challenges in record time.
- Using 11.3 in<sup>3</sup> (185.3 cm<sup>3</sup>) Hydraulic motor, produces 4783 ft•lb (6484.9 N•m) of torque at the bar, at 15.1 rpm.
- Compact, modular components allow fast, easy setup, maximizing efficiencies, and minimizing downtime.

### Versatile and Flexible

- Machines bores from 14.5 - 85.6 inches (368.3- 2174.2 mm) in diameter, and faces from 14 - 97.7 inches (355.6 - 2481.6 mm) with various facing attachments.
- ID and End mount bearings feature spherical taper-lock roller bearings.
- End mount can be fine adjusted by +/- 0.25 inches (6.35 mm) to center the bar.
- Optional dual action boring/facing arms increase facing range, and allow for both boring and facing without switching equipment. Full-length square ways on boring/facing arms allow for quick positioning anywhere along the arm. Attaches to the net fit tool carrier by compression-clamping, to provide maximum tool stability.
- Machine is highly adjustable. The tool carrier, half nut, alignment of boring/facing arm, and tool carriage can each be adjusted to maximize machining performance.
- Net fit tool carrier can be clamped to bar for facing operations. For boring operations, carrier can be adjusted to remove clearance between carrier and the bar. This flexibility also ensures maximum rigidity for either operation



- Net fit tool carrier designed with a split frame to simplify installation on the boring bar. It can be configured to use either the boring head set for boring or facing, or the new boring/facing arm assembly.
- With leading & trailing boring head configuration, 2 boring heads can be used simultaneously.
- For even greater facing range with longer radial travel, the new boring/facing arms are available. Setup is quick & easy, featuring industry standard quick-change tooling for both boring and facing operations.
- Highly versatile tool holder block accepts industry standard tooling with a nominal 1 inch (25.4 mm) square shank.
- Tool post on the boring/facing arm can be rotated to provide maximum flexibility in machining setup (including some cantilevered configurations).

### High Quality Design

- Features a uniquely-designed modular tool carrier which provides a new level of strength and rigidity by channeling machining forces directly to the boring bar through strategically-located adjustable guide shoes.
- Hard chromed bars, straight to within 0.001 inch per foot (0.0254 per 304.8 mm)
- Optional gun-drilled bars with optical targets available.
- Adjustable, removable half nut increases net fit tool carrier flexibility. Easy removal of tool carrier allows for machining of multiple bores.
- Backlash adjustment nut allows in-the-field adjustment to eliminate backlash in the tool carrier, and extend the life of the machine.

# SPECIFICATIONS

	US	Metric
<b>Boring and Facing Ranges</b>		
Boring diameter range, standard stack block assembly:	14.5 - 85.6 inches	368.3 - 2174.2 mm
Boring diameter range boring/facing arm assembly:		
with 26 inch (660.4) boring/facing arm assembly	28.9 - 43.7 inches	734.1 - 1110.0 mm
with 34 inch (863.6) boring/facing arm assembly	36.5 - 59.7 inches	927.1 - 1516.4 mm
with 53 inch (1346.2) boring/facing arm assembly	55.1 - 97.7 inches	1399.5 - 2481.6 mm
Facing diameter range, mechanical facing head assembly:		
with 5, 8, or 12 inch (127.0, 203.2 or 304.8 mm)	24.5 - 80 inches	622.3 - 2032.0 mm
mechanical facing head assemblies		
(5 and 8 inch facing head assemblies have 8 inch stroke, 12 inch facing head assembly has 12 inch stroke)		
Facing diameter range, slide arm assembly:		
with 26 inch (660.4) boring/facing arm assembly	23.1 - 43.7 inches	586.7 - 1110.0 mm
with 34 inch (863.6) boring/facing arm assembly	23.1 - 59.7 inches	586.7 - 1516.4 mm
with 53 inch (1346.2) boring/facing arm assembly	23.1 - 97.7 inches	586.7 - 2481.6 mm
Facing diameter range, boring/facing arm assembly (tool post reversed):		
("tool post reversed" refers to rotating the tool post so that the tool is on the bar side of the tool post.)		
with 26 inch (660.4) boring/facing arm assembly	14.0 - 17.4 inches	355.6 - 442.0 mm
with 34 inch (863.6) boring/facing arm assembly	14.0 - 27.4 inches	355.6 - 696.0 mm
with 53 inch (1346.2) boring/facing arm assembly	14.0 - 49.4 inches	355.6 - 1254.8 mm
<b>Performance Data</b>		
Rotational Drive Unit (RDU) Gear Ratio:	20 : 1	10 : 1 optional (2xfast, 1/2torque)
Hydraulic motor size affects torque and speed		
Theoretical values calculated using a 25 Hp hydraulic power unit producing 2000 psi (13790 kPa) continuous, [normal operation is 1200 psi (8270 kPa)] and pumping 15 gpm (68 l/min).		
Hydraulic motor size range:	7.3 - 17.9 in <sup>3</sup>	119.6 - 293.3 cm <sup>3</sup>
Boring Bar Torque with 20:1 RDU:	3350 - 6068 ft•lb	4542 - 8227.1 N•m
Max boring rpm with 20:1 RDU:	23.5 - 9.6 rpm	23.5 - 9.6 rpm
For example, with 11.3 in <sup>3</sup> (185.3 cm <sup>3</sup> ) hydraulic motor (43457):		
Boring Bar Torque with 20:1 RDU:	4783 ft•lb	6484.9 N•m
Max boring rpm with 20:1 RDU:	15.1 rpm	15.1 rpm
Feed Rate of mechanical Axial Feed Unit (AFU):	0.003 - 0.030 in/rev.	0.076 - 0.762 mm/rev.
Feed Rate of electric Axial Feed Unit (AFU) In "slow" speed	0 - 0.3 in/min.	0 - 7.62 mm/min.
<b>Measures</b>		
Shipping weight (estimated):		
(machine with RDU, AFU, boring head set, tool carrier, tool kit, and hydraulic motor.)		
for machine (metal crate)	5700 lbs.	2585.5 kg
for machine (wood crate)	5850 lbs.	2653.5 kg
for 1 Bearing	1070 lbs.	485.3 kg
for boring bar	14.5 lbs/inch	2.6 kg/cm
15 Hp or 25 Hp Hydraulic Power Unit	1073 lbs	486.7 kg
Shipping dimensions:		
Machine, in wood crate, W, D, H	18.5 x 34 x 23.7 inches	469.6 x 863.6 x 602 mm
Machine, in steel crate, W, D, H	20 x 40 x 25 inches	508 x 1016 x 635 mm
Bearing (each bearing shipped separately) W, D, H	40 x 40 x 12.7 inches	1016 x 1016 x 322.6
12 foot (365.8 cm) bar W, D, H	24 x 18 x 152 inches	609.6 x 457.2 x 3860.8 mm
15 or 25 Hp Hydraulic Power Unit W, D, H	64 x 30 x 50 inches	1625.6 x 762 x 1270 mm

All dimensions should be considered reference. Contact your Climax Representative for precision dimensions. Specifications are subject to change without notice. There are no systems or components on this machine that are capable of producing hazardous EMC, UV or other radiation hazards. The machine does not use lasers nor does it create hazardous materials such as gasses or dust.

# TOOL CONFIGURATIONS

Configure your BB8100 in nine easy steps.

To configure your BB8100 Boring Machine:

- 1 Select a Base Unit
- 2 Select an Axial Feed Assembly
- 3 Select Bearing Assemblies
- 4 Select a Boring Bar
- 5 Select a Hydraulic Motor Assembly
- 6 Select Boring Diameter Ranges
- 7 Select Boring Heads
- 8 Select a Boring/Facing Arm Assembly
- 9 Select a Shipping Container

To configure the boring machine you require, simply select the option you need in each step, then contact your Climax representative.

<b>1 Base Unit</b>	
Rotational drive unit, tool carrier assembly, tool kit, and instruction manual.	
Base unit, 20:1 gear ratio	<b>54453</b>
Base unit, 10:1 gear ratio	<b>54454</b>
<b>2 Axial Feed Assembly</b>	
Mechanical axial feed assembly	<b>23393</b>
Electrical axial feed assembly, 120V	<b>43734</b>
Electrical axial feed assembly, 230V	<b>40724</b>
<b>3 Bearing Assemblies</b>	
End mount self-aligning bearing assy w/ spider	<b>23550</b>
End mount self-aligning bearing assy, no spider	<b>25074</b>
ID mount non self-aligning bearing assembly diameter of 23 - 27.5 inches (584.2 - 698.5 mm)	<b>18572</b>
ID mount non self-aligning bearing assembly diameter of 23 - 35 inches (584.2 - 889.0 mm)	<b>18573</b>
ID mount non self-aligning bearing assembly diameter of 23 - 49.5 inches (584.2 - 1257.3 mm)	<b>18574</b>
ID mount non self-aligning bearing assembly diameter of 23 - 63.5 inches (584.2 - 1612.9 mm)	<b>18575</b>
ID mount non self-aligning bearing assembly diameter of 23 - 77 inches (584.2 - 1955.8 mm)	<b>18576</b>
Non self-aligning bearing assembly, no spider	<b>18533</b>
* Multiple units may be ordered.	
<b>4 Boring Bar (8 inch (203.2 mm) diameter)</b>	
Boring bar assembly, 8 feet (243.8 cm)	<b>34305</b>
Boring bar assembly, 10 feet (304.8 cm)	<b>34306</b>
Boring bar assembly, 12 feet (365.8 cm)	<b>34307</b>
Boring bar assembly, 14 feet (426.7 cm)	<b>34308</b>
Boring bar assembly, 16 feet (487.7 cm)	<b>34309</b>
Boring bar assembly, 18 feet (548.6 cm)	<b>34310</b>
Boring bar assembly, 20 feet (609.6 cm)	<b>34311</b>

<b>4 Boring Bar , Contginued (8 inch (203.2 mm) diameter)</b>	
Gun-drilled bars with optical targets:	
Boring bar assembly, with optics, 8 feet (243.8 cm)	<b>17602</b>
Boring bar assembly, with optics, 10 feet (304.8 cm)	<b>17603</b>
Boring bar assembly, with optics, 12 feet (365.8 cm)	<b>17604</b>
Boring bar assembly, with optics, 14 feet (426.7 cm)	<b>17605</b>
Boring bar assembly, with optics, 16 feet (487.7 cm)	<b>17606</b>
Boring bar assembly, with optics, 18 feet (548.6 cm)	<b>17607</b>
Boring bar assembly, with optics, 20 feet (609.6 cm)	<b>17608</b>
* Multiple units may be ordered.	
<b>5 Hydraulic Motor Assembly</b>	
Hydraulic motor assembly, 7.3 CIR (120 cm <sup>3</sup> /rev)	<b>43455</b>
44 bar rpm @ 15 gpm**	
Hydraulic motor assembly, 8.9 CIR (146 cm <sup>3</sup> /rev)	<b>43456</b>
36 bar rpm @ 15 gpm**	
Hydraulic motor assembly, 11.3 CIR (185 cm <sup>3</sup> /rev)	<b>43457</b>
29 bar rpm @ 15 gpm**	
Hydraulic motor assembly, 14.1 CIR (231 cm <sup>3</sup> /rev)	<b>43458</b>
22 bar rpm @ 15 gpm**	
Hydraulic motor assembly, 17.9 CIR (293 cm <sup>3</sup> /rev)	<b>43459</b>
18 bar rpm @ 15 gpm**	
* Multiple units may be ordered.	
** Theoretical, calculated values shown	
<b>6 Boring Diameter Ranges (select tooling in next step)</b>	
Stack up blocks, boring diameter range 14.5 - 26.6 inches (368.3 - 675.6 mm)	<b>81254</b>
Stack up blocks, boring diameter range 14.5 - 38.4 inches (368.3 - 975.4 mm)	<b>81255</b>
Stack up blocks, boring diameter range 14.5 - 62.0 inches (368.3 - 1574.8 mm)	<b>86630</b>
Stack up blocks, boring diameter range 14.5 - 85.6 inches (368.3 - 2174.24 mm)	<b>81256</b>
<b>7 Boring Heads</b>	
Micro adjust boring head 1 inch*	<b>79021</b>
Solid tooling boring head, leading & trailing	<b>81246</b>
* Multiple units may be ordered for leading & trailing	
<b>8 Boring/Facing Arm Assembly</b>	
Mechanical facing head assy, 5 inch (127.0 mm)	<b>21115</b>
Mechanical facing head assy, 8 inch (203.2 mm)	<b>38654</b>
Mechanical facing head assy, 12 inch (304.8 mm)	<b>22359</b>
Boring/facing arm assembly, 26 inch (660.4 mm)	<b>54401</b>
Boring/facing arm assembly, 34 inch (863.6 mm)	<b>54402</b>
Boring/facing arm assembly, 53 inch (1346.2 mm)	<b>54403</b>
<b>9 Shipping Container</b>	
Plywood hinged crate, 39 x 58 x 31inches (990.6 x 1473.2 x 787.4 mm)	<b>42955</b>
Metal shipping container, 39 x 58 x 31inches (990.6 x 1473.2 x 787.4 mm)	<b>54368</b>
* Machine components only.	
Bars and bearings available in wood only.	

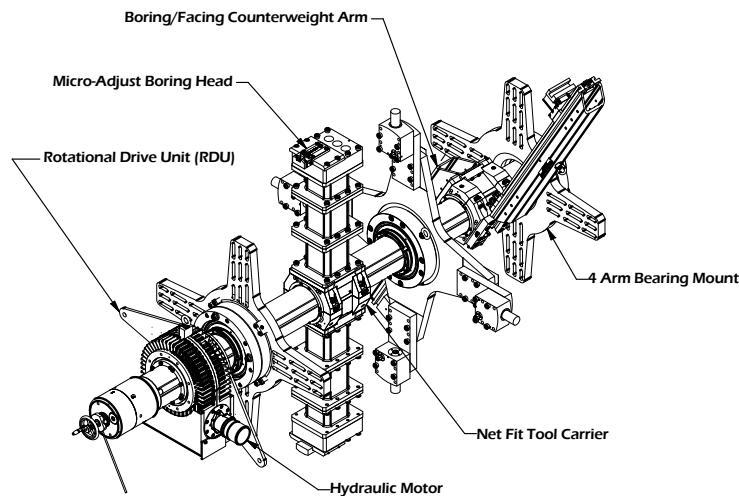

# OPERATIONAL DIMENSIONS

Dimensions in Inch (mm)

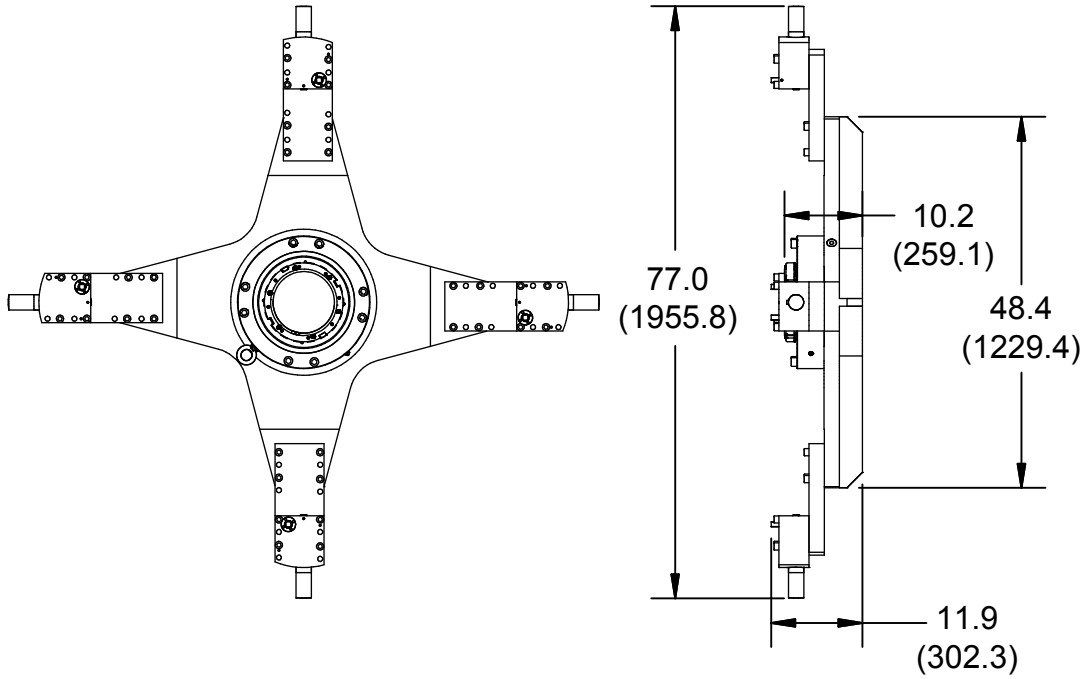

ID Mount 48.5 - 77 inches (1231.9 - 1955.8 mm)

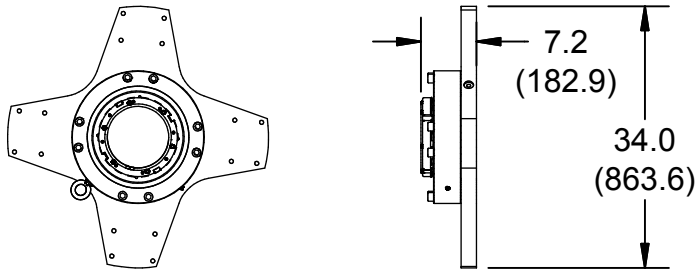

ID Mount 34.25 - 62.75 inches (870.0 - 1593.9 mm)  
(Centering Assembly not shown)

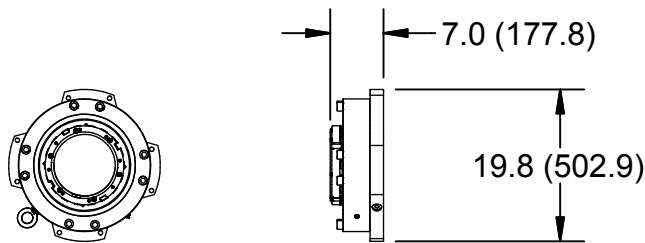

ID Mount 20.0 - 48.5 inches (508.0 - 1231.9 mm)  
(Centering Assembly not shown)

# OPERATIONAL DIMENSIONS

Dimensions in Inch (mm)

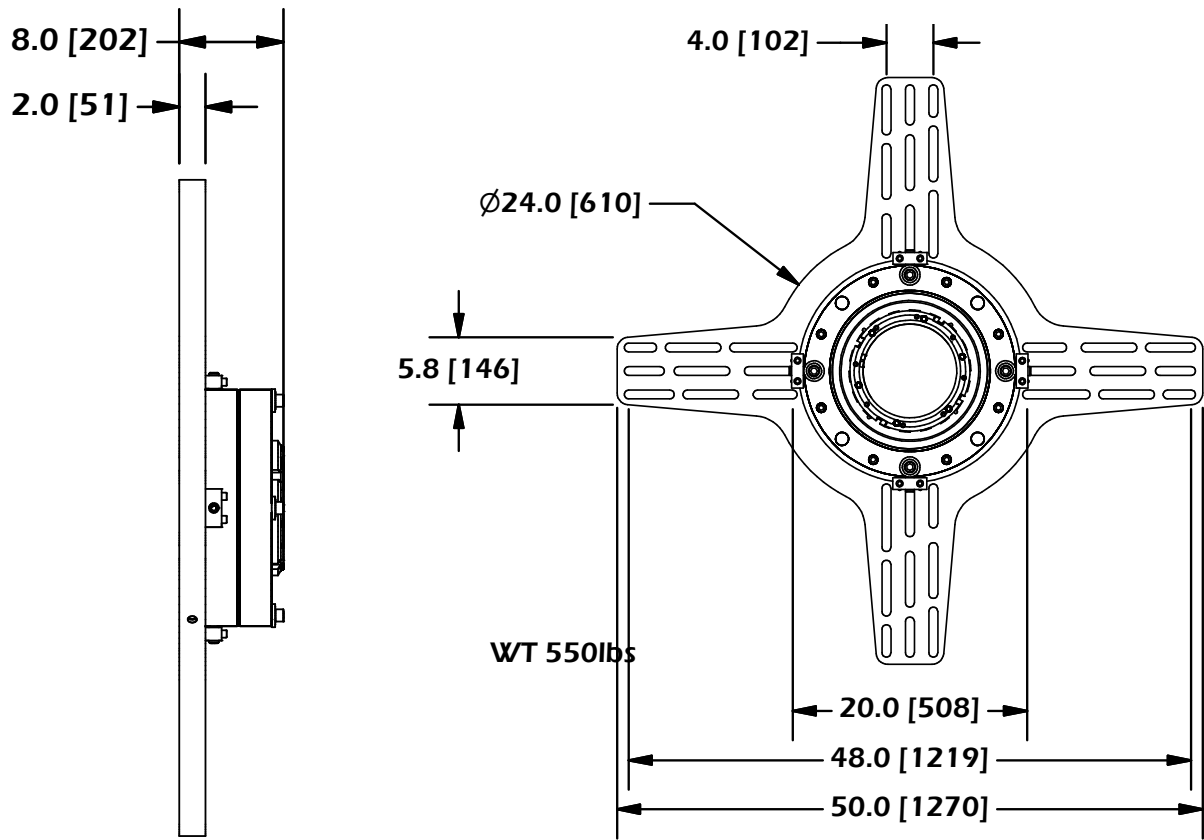

Spider Assembly 4-Arm Self-Aligning End Bearing Support

# OPERATIONAL DIMENSIONS

Dimensions in Inch (mm)

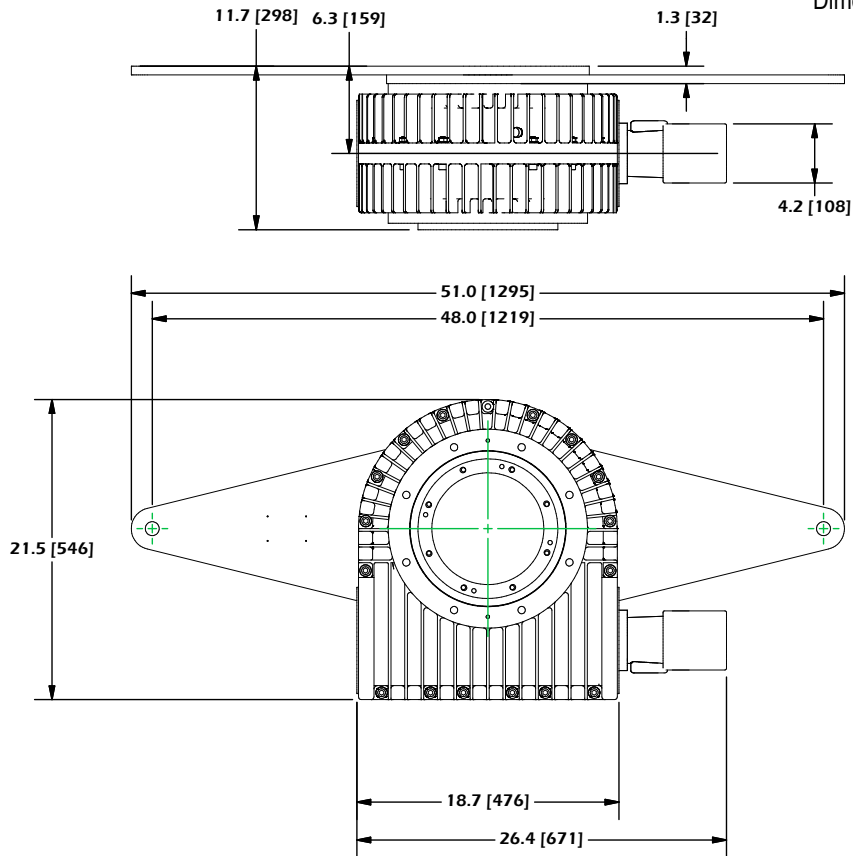

Rotational Drive Unit

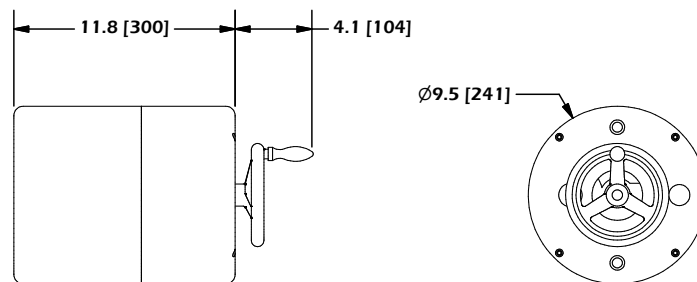

Mechanical Axial Feed Assembly

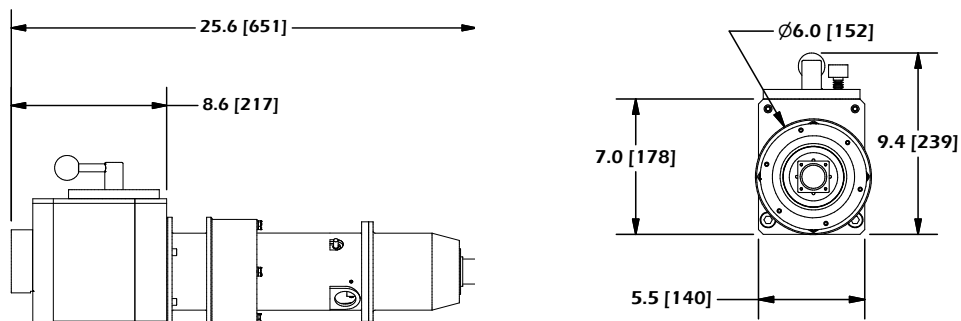

Electrical Axial Feed Assembly

# OPERATIONAL DIMENSIONS

Dimensions in Inch (mm)

**MAX FACE/BORE**  
 26" Ø43.7 [1110]  
 34" Ø59.7 [1516]  
 53" Ø97.7 [2481]

**MIN FACE**  
 ALL ARM LENGTHS Ø23.1 [587]

**MIN FACE SWING**  
 26" Ø32.9 [835]  
 34" Ø40.6 [1031]  
 53" Ø59.2 [1505]

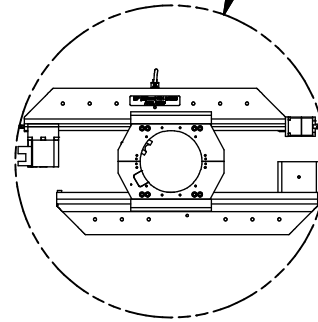
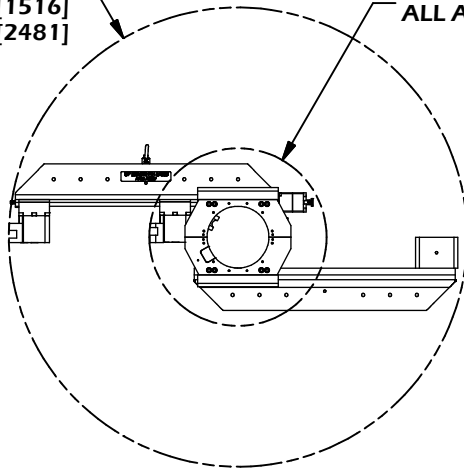

**MAX FACE**  
**TOOL POST REVERSED**  
 26" Ø17.4 [442]  
 34" Ø27.4 [696]  
 53" Ø49.4 [1254]

**MIN FACE**  
**TOOL POST REVERSED**  
 ALL ARM LENGTHS Ø14.0" [356]

**MIN BORE**  
 26" Ø28.9 [733]  
 34" Ø36.5 [927]  
 53" Ø55.1 [1399]

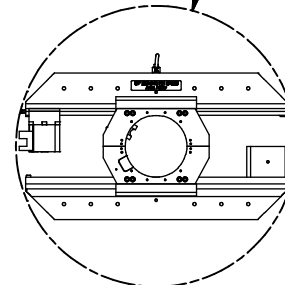
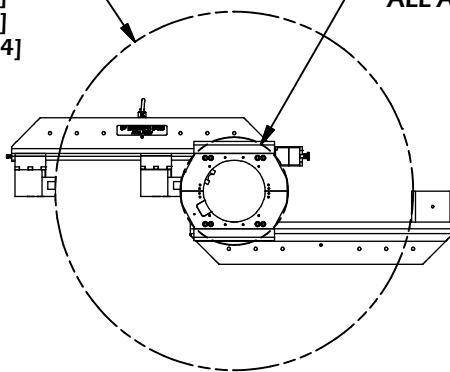

Slide arm configurations

# CLIMAX TRAINING AND SUPPORT

CLIMAX has been teaching the fundamentals and finer points of portable machine tool operation for more than 50 years.

Whether it's a regularly scheduled course at one of our seven Global Training Centers or a custom curriculum conducted with your team, at your facility, your technicians will benefit from courses developed by the most experienced and respected professionals in the business.

Regularly scheduled courses in basic and advanced tool operation are available. A vast majority of every program is devoted to hands-on activities, skills development, and OEM Certification covering the following subject matters: operator safety, tool component review, setup and mounting, standard and advanced operational techniques, overview of cutting tools and recommended usage, and maintenance procedures.

Training is available at the following seven Global Training Centers:

- Portland, Oregon
- Houston, Texas
- Gonzales, Louisiana
- Wadsworth, Ohio
- Manchester, United Kingdom
- Düren, Germany
- Dubai, United Arab Emirates

Call us today to schedule training for your team! ,



## Call CLIMAX for:

### Rentals

With worldwide rental depot locations, you are never far away from a CLIMAX tool.

### On-site Training

Need some refresher courses in setting up and operating your CLIMAX machine tool?

### Custom Projects

CLIMAX has been solving complicated machining, welding and valve testing problems for our customers since 1966

Connect with us:

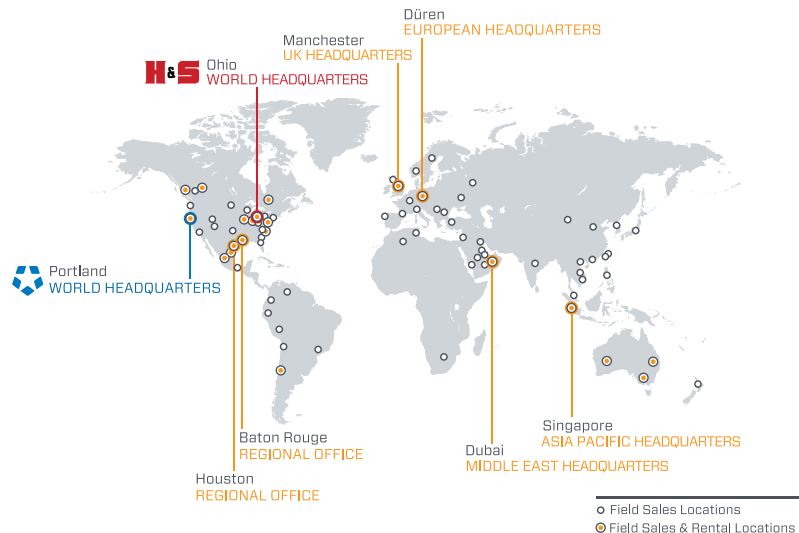

### H&S World Headquarters - USA

Address: 715 Weber Dr., Wadsworth, Ohio 44281  
Tel: +1 330 336 4550  
Fax: +1 503 538 7600  
Email: info@hstool.com

### CLIMAX World Headquarters - USA

Address: 2712 E. 2nd St, Newberg, Oregon 97132  
Tel: +1 503 538 2185  
Fax: +1 503 538 7600  
Email: info@cpmt.com

### Asia Pacific

Address: 308 Tanglin Rd #02-01, Singapore 247974  
Tel: +65 6801 0662  
Fax: +65 6801 0699  
Email: ClimaxAsia@cpmt.com

### European

Address: Am Langen Graben 8, 52353 Düren, Germany  
Tel: (+49) (0) 2421 9177 0  
Fax: (+49) (0) 2421 9177 29  
Email: ClimaxEurope@cpmt.com

### Middle East

Address: Warehouse #5, Plot: 369 272, Um Sequim Road, Dubai, UAE  
Tel: +971 4 321 0328  
Email: ClimaxUAE@cpmt.com

### United Kingdom

Address: Unit 7 Castlehill Industrial Estate, Bredbury Industrial Park, Horsfield Way, Stockport SK6 2SU  
Tel: +44 (0) 161 406 1720  
Email: info@cpmt.com