

For your BB5000 Portable Boring Machine

Robust, high quality facing head expands BB5000 capabilities

- This rugged, heavy-duty facing head has a much higher removal rate to handle large diameter facing jobs with ease.
- Broad facing range, from 2.25 to 24 inches (57.2 - 609.6 mm) without repositioning.
- Swing diameter from 20.1 to 25.3 inches (510.5 to 642.6 mm).
- Simple and robust feed trip mechanism moves the carrier inward or outward automatically.
- Rigid tool carrier and slide assembly.
- Automatic radial feed is provided by a trip-activated feed mechanism that advances from 0 to 0.011 inches (0 to 0.279 mm) per revolution.

Easy, flexible setup and operation

- The adjustable facing head will face in either direction.
- Quickly mount the facing head anywhere on the boring bar; saves time and helps get your job done quickly.

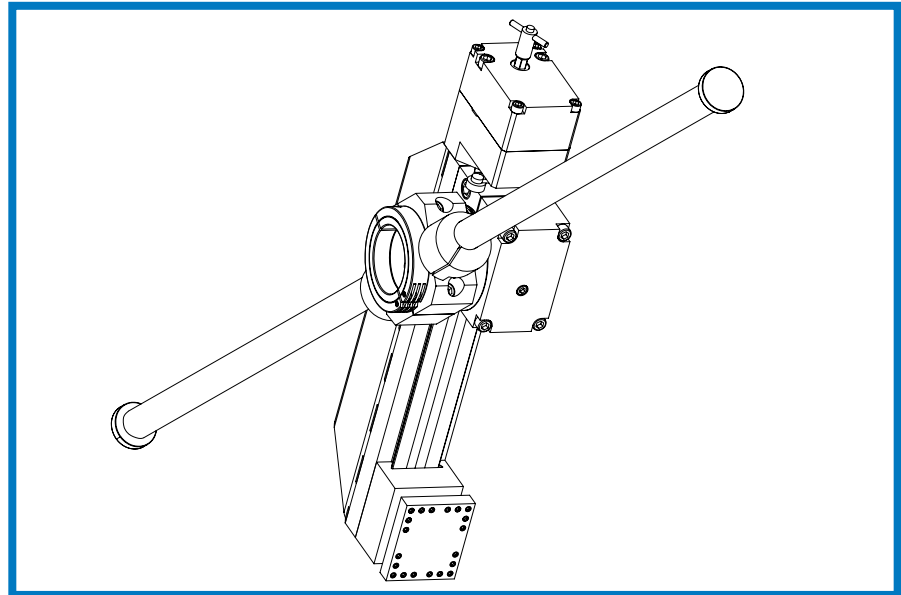

SPECIFICATIONS

	US	Metric
Facing Diameter	2.25 – 24.0	57.2 – 609.6
Swing Diameter (Turning arm can be repositioned)	20.1 – 25.3	510.5 – 642.6
Feed, Feed Rate	Automatic, 0 – 0.11/revolution	Automatic, 0 – 2.794/revolution
Operating Weight	40 lbs	18.2 kg
Shipping Weight	110 lbs	49.9 kg
Shipping Dimensions (shipped in 1 container)	38-1/8 x 17-13/16 x 6-1/8 inches	968.4 x 452.4 x 155.6 cm

Machining Example #1		Machining Example #2	
Material:	A-36 steel plate	Material:	A-36 steel plate
Motor:	Hydraulic with 11.3 in ³ (185.2 cm ³) displacement (Climax PN 21532)	Motor:	Electric 112/55 bar RPM (Climax PN 37557)
HPU/Flow:	5 Hp, 4.7 gpm (5 Hp, 17.8 L/min)	Feed Rate:	0.007 inches (0.178 mm) per revolution
Feed Rate:	0.004 inches (0.102 mm) per revolution	Feed Direction:	Feeding in
Feed Direction:	Feeding in	Bar RPM:	24
Bar RPM:	24	Depth of Cut:	0.030 inches (0.762 mm)
Depth of Cut:	0.020 inches (0.508 mm)	Surface Finish:	350 µin
Surface Finish:	250 µin	Flatness:	0.002 over 15 inches (0.051 over 381 mm)
Flatness:	0.003 over 20 inches (0.08 over 508 mm)	Tool Bit:	HSS cutter (Climax PN 32344)
Tool Bit:	HSS cutter (Climax PN 32344)	Bearing Spacing:	49.5 inches (1257.3 mm) from back side of bearing mounts
Bearing Spacing:	49.5 inches (1257.3 mm) from back side of bearing mounts	Cutting Oil:	None
Cutting Oil:	None	Machine Orientation:	Boring bar mounted horizontally with 2 double arm mounts
Machine Orientation:	Boring bar mounted vertically with 2 double arm mounts		

Ordering Information

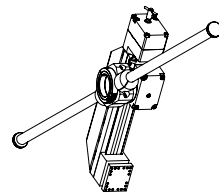
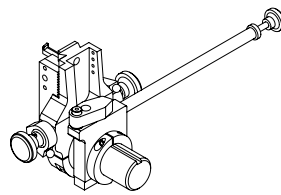
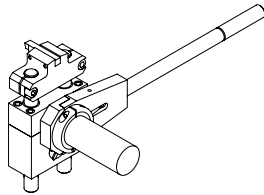

Climax PN	31412	30051	30044	35858	36936	36954	45040	60301
Item Name	Adjustable Range Facing Heads			Facing & Grooving Heads			Heavy Duty Facing Head	
Bar Dia.	1-¼ (31.8)	2.0 (50.8)	2-¼ (57.2)	1-¾ (44.5)	2-¼ (57.2)	2-¼ (57.2)	2-¼ (57.2)	2.0 (50.8 mm)
Swing Dia.	6.6 - 9.4 (167.6 - 238.8)	9.1 - 22.2 (231.1 - 563.9)	10.0 - 18.6 (254 - 472.4)	13.5 (342.9)	13.5 (342.9)	20.3 (515.6)	20.1 - 25.3 (510.5 - 642.6)	
Facing Dia.	2.1 - 8.8 (53.3 - 223.5)	2.5 - 18 (63.5 - 457.2)	2.5 - 18 (63.5 - 457.2)	2.5 - 12 (63.5 - 304.8)	2.5 - 12 (63.5 - 304.8)	2.5 - 19.0 (63.5 - 482)	2.25 - 24.0 (57.2 - 609.6)	
Grooving Dia.	n/a	n/a	n/a	3.5 - 12 (88.9 - 304.8)	4.0 - 12.0 (101.6 - 304.8)	4.0 - 19.0 (101.6 - 482.6)	3.3 - 24.0 (83.8 - 609.6)	

All dimensions should be considered reference. Contact your Climax Representative for precision dimensions. Specifications are subject to change without notice. There are no systems or components on this machine that are capable of producing hazardous EMC, UV or other radiation hazards. The machine does not use lasers nor does it create hazardous materials such as gasses or dust.

OPERATIONAL DIMENSIONS

Dimensions in inch (mm)

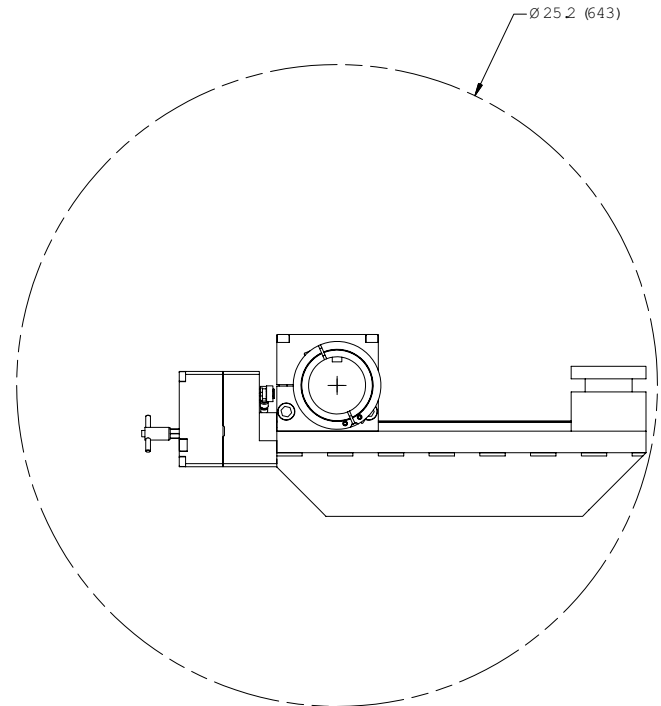
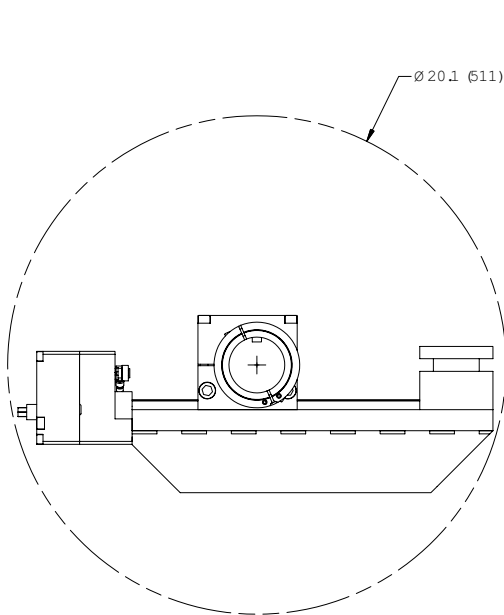
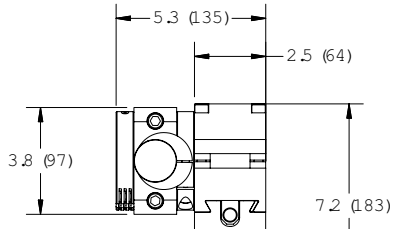

APPLICATION PHOTOS

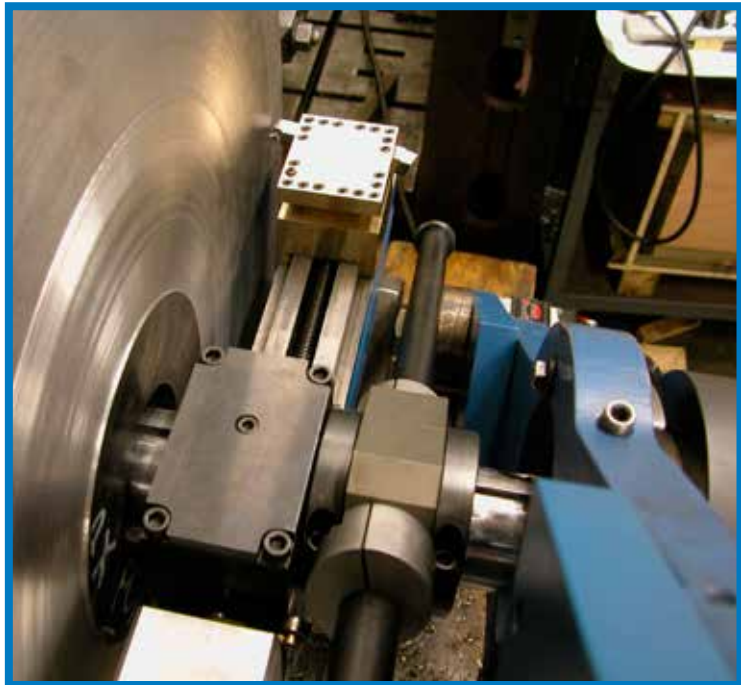

Training at the Global Learning Center

Climax has been teaching the fundamentals and fine points of portable machine tool operation for practically as long as we've been inventing and building the tools.

At the Climax Global Learning Center situated in our corporate headquarters near Portland, Oregon, we provide training for machine tool operators on portable machine tool safety, and machine setup and operation. Trainees also receive technical tips and tools to improve operational efficiencies, with the vast majority of every program devoted to hands-on activities and skill development.



The Climax instructional team includes specialists in shipbuilding, power generation, civil engineering, bridge re-building, petrochemical and other industries.

Whether it's a regularly scheduled course at the Global Learning Center, or custom curriculum conducted at your facility, your machinists will benefit from courses developed by some of the most respected authorities in the business.

Call us today to register for a regularly scheduled class, or talk to us about how we can customize a training program for your specialized application.



CLIMAX GLOBAL LOCATIONS



Call Climax for:

On-site Training

Need some refresher courses in setting up and operating your Climax machine tool?

Special Projects

Climax has been solving complicated on-site machining and welding problems for our customers since 1964.

Rentals

With 16 worldwide rental depot locations, you are never far away from a Climax portable machine tool.

Connect with us:    

World Headquarters

2712 E. Second Street
Newberg, Oregon 97132 USA
Worldwide Telephone: 1.503.538.2185
N. America Toll-Free: 1.800.333.8311
Fax: 1.503.538.7600
Email: info@cpmt.com

European Headquarters

Am Langen Graben 8
52353 Düren, Germany
Telephone: (+49) (0) 2421.9177.0
Fax: (+49) (0) 2421.9177.29
Email: info@cpmt.de